

Cosmoplast®



HDPE DRAINAGE SYSTEM TECHNICAL CATALOGUE



BS EN 1519-1
*Refer to certificate for details

Cosmoplast, a primary member of Group Harwal, has been at the forefront of the plastic industry in the Gulf region since its founding in 1976. Through constant growth and product diversification, the company continues to be the largest thermoplastic pipe manufacturer in the region.

Continuously enhancing its capabilities in plastic manufacturing technologies, Cosmoplast now utilizes a diverse range of materials such as uPVC, polyethylene (PE100, PE 80, LLDPE), cross linked polyethylene (PEX), random copolymer polypropylene (PP-R), and Glass-Reinforced Plastic (GRP), CPVC & RTP.

Cosmoplast's ongoing research and development programs continue to add new products to its pipeline systems product range that now includes pre-insulated pipes, reinforced thermoplastic pipes, specialized plumbing systems and fabricated uPVC and GRP manhole systems. Its state of the art engineering, design and tool room facilities are fully capable of manufacturing moulds, dies, machinery equipments and other specialized tooling requirements to meet the company's continual expansion and product development requirements.

With this extended product range, Cosmoplast's pipeline systems cater to an extensive range of market sectors and applications covering infrastructure development, plumbing, oil & gas, district cooling, irrigation, landscaping and water extraction.

An ISO 9001 certified company, Cosmoplast has its production facilities based in Abu Dhabi converting over 75,000 metric tones of plastic per annum. In addition to these, Cosmoplast also has upcoming facilities in Saudi Arabia, Moscow and Kaliningrad.

COSMOPLAST PIPELINE SYSTEMS PRODUCT RANGE INCLUDES:

INFRASTRUCTURE PIPELINE SYSTEMS (uPVC, PE, GRP)

uPVC and Polyethylene pipeline systems with sizes ranging from 15mm up to 1200mm, well casings and screens and GRP pipeline systems with sizes from 100mm up to 1400mm for applications including

- Water extraction
- Water distribution
- Drainage
- Sewerage
- Gas distribution
- Cable ducting

PLUMBING SYSTEMS (UPVC, PP-R, PEX, HDPE DRAINAGE, CPVC)

Comprehensive range includes uPVC systems for drainage, random polypropylene (PP-R) [plain, fiber and aluminium composite] and cross linked polyethylene (PEX) systems for water and sanitary applications and uPVC high pressure pipes and fittings for water supply and A/C Drain. Plumbing accessories such as pipe clamps, polyethylene compression fittings, solvent cements, lubricants and adhesives compliment this product range.

PRE-INSULATED PIPES (HDPE-HDPE, HDPE-GRP, HDPE-STEEL, GRP-HDPE, GRP-GRP, GRP-STEEL)

Jacket – core pipe combination with polyurethane insulation are used for applications such as District Cooling systems, Oil & Gas and other industrial applications. Cosmoplast provides HDPE and GRP pipes as jackets and HDPE, GRP and steel as core pipes.

IRRIGATION SYSTEMS (LLDPE)

Consists of high precision inline drip pipes and landscape and lawn edging. This range also includes saline resistant valves, drainage systems, sprinklers and central controllers.

REINFORCED THERMOPLASTIC PIPES (RTP)

Available in length of upto 500m, with a working pressure of 150 Bar at a temperature of 60 degrees celcius. RTP is used for gas distribution networks, oil flow lines and water injection lines.

Cosmoplast PE Soil, Waste & Vent System

Introduction

Cosmoplast HDPE drainage system is the ultimate solution for all types of drainage including kitchen waste, soil and waste, above ground, below ground and chemical waste.

Cosmoplast HDPE drainage system is suitable for residential and industrial buildings, for laboratories, embedded in concrete or buried underground.

Cosmoplast HDPE pipes and fittings are available in sizes from diameter 32 mm to 315 mm. Bigger sizes can also be fabricated on request.



Material

High-density polyethylene (HDPE) is suitable for producing drainage pipes and fittings for residential and industrial buildings for the conveyance of non-pressure waste intermittently to a maximum temperature of 95°C.

The HDPE material is characterized by:

- High flexibility.
- High impact strength.
- Excellent mechanical characteristics.
- High corrosion resistance.
- High chemical resistance.
- Recyclable material.

Physical & mechanical properties of HDPE material

Property	Test Method	Units	PE 80	PE 100
Density (Compound)	ISO 1183	Kg/m ³	956	959
Melt Flow Rate(190°C/5kg)	ISO 1133	g/10 min	0.3	0.25
Tensile Stress at Yield(50mm/min)	ISO 527-2	MPa	20	25
Elongation at Break	ISO 527-2	%	> 600	> 600
Charpy Impact Strength, notched	ISO 179/1eA	kJ/m ²	14	16
Carbon Black Content	ASTM D 1603	%	2-2.5	2-2.5
Vicat Softening Point	ASTM D 1525	°C	118	122
Brittleness Temperature	ASTM D 746	°C	< -70	< -70
ESCR (10% Igepal), F50	ASTM D 1693A	Hrs.	>10,000	>10,000
Thermal Conductivity	DIN 52612	W/m ^{°K}	0.4	0.4
Linear Thermal Expansion	ASTM D 696	mm/m°C	0.18	0.18

Standards:

Cosmoplast HDPE drainage pipes and fittings are manufactured according to the British & European Standard BSEN 1519-1 which superseded the German Standards DIN19535-1 and DIN19535-2.

Dimensions of HDPE drainage pipes according to BSEN 1519-1

Nominal Outside Diameter (mm)	Mean Outside Diameter (mm)		Wall Thickness (mm)		Wall Thickness (mm)	
			SN2/SDR33		SN4/SDR26	
			Series S 16 **		Series S 12.5	
	Min	Max	Min	Max	Min	Max
32	32.0	32.3	3.0	3.5	3.0	3.5
40	40.0	40.4	3.0	3.5	3.0	3.5
50	50.0	50.5	3.0	3.5	3.0	3.5
56	56.0	56.5	3.0	3.5	3.0	3.5
63	63.0	63.6	3.0	3.5	3.0	3.5
75	75.0	75.7	3.0	3.5	3.0	3.5
80	80.0	80.8	3.0	3.5	3.1	3.6
90	90.0	90.9	3.0	3.5	3.5	4.1
100	100.0	100.9	3.2	3.8	3.8	4.4
110	110.0	111.0	3.4	4.0	4.2	4.9
125	125.0	126.2	3.9	4.5	4.8	5.5
160	160.0	161.5	4.9	5.6	6.2	7.1
200	200.0	201.8	6.2	7.1	7.7	8.7
250	250.0	252.3	7.7	8.7	9.6	10.8
315	315.0	317.9	9.7	10.9	12.1	13.6

Notes:

Series 16 (S 16) is suitable for application area inside buildings and outside buildings fixed on the wall (application area B).

Series 12.5 (S 12.5) is suitable for application area under and within 1 metre from the building where the pipes and fittings are buried underground and connected to the soil and waste discharge system of the building (application area BD).

Characteristics and Advantages of Cosmoplast HDPE Drainage System:

Long Durability:

Due to its chemical stability and corrosion resistance, Cosmoplast HDPE drainage pipes and fittings are expected to last for up to 50 years.

High Flexibility:

Resulted from the high quality virgin HDPE raw material used by Cosmoplast to produce its pipes and fittings. The flexibility of Cosmoplast HDPE pipes and fittings guarantees crush resistance and ultimate performance when pipes are buried in areas subject to traffic and when passing through expansion joints.

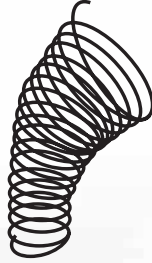

High Corrosion Resistance:

Resulted from the basic characteristics of the HDPE material that ensures high resistance to corrosion.

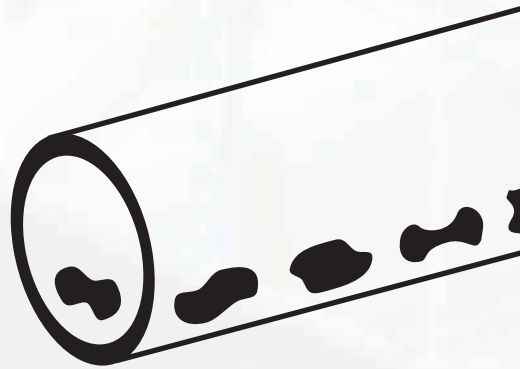

High Chemical Resistance:

HDPE material has good resistance to acids and excellent resistance to Alkaline and Solvents. HDPE is also resistant to wide range of chemicals which renders the HDPE drainage system the ultimate solution for chemical and industrial drainage networks. The system is insoluble in all inorganic or organic solutions at room temperature.

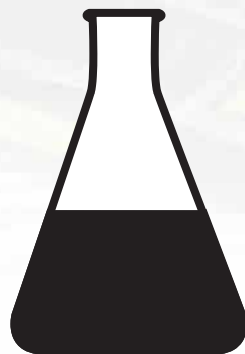

Low Noise System:

Thanks to the acoustic insulation feature of the HDPE material which helps in reducing the noise level while system is operational. This property makes Cosmoplast HDPE drainage system ideal for installations in universities, hospitals, hotels...etc.

High resistance to extreme temperatures:

Cosmoplast HDPE drainage system can be safely used with fluids at high temperatures up to 80°C. Short time loading at temperatures up to 100°C is permissible. Cosmoplast HDPE drainage system is also suitable for subzero temperatures and adapts elastically with expansion and contraction resulted from freezing and defrosting.



Strict Quality Control:

Cosmoplast HDPE pipes and fittings are subjected to several in-house quality control tests during production and on the finished products. They are also subjected to external tests by independent testing institutes to ensure the highest quality.



High Impact Resistance:

Cosmoplast HDPE is highly resistant to impacts and therefore unbreakable at room temperatures and at subzero temperatures.



Lightweight:

Cosmoplast HDPE drainage system is light in weight compared to the traditional drainage systems which makes it easy for handling, storage and transportation.

Smooth Internal Surface:

HDPE pipes and fittings are more resistant to solids build up or scaling.

Application Areas

Drainage systems inside buildings

Cosmoplast HDPE drainage system can be used in residential buildings, commercial buildings, industrial buildings and laboratories.

Installations inside concrete

Cosmoplast HDPE drainage pipes and fittings can be installed inside slabs and concrete thanks to its flexibility and high abrasion resistance.



External and underground drainage

Cosmoplast HDPE drainage pipes and fittings can be installed outside buildings underground thanks to its flexibility and resistance to crush and abrasion.



Installation Techniques

Cosmoplast HDPE drainage pipes and fittings can be jointed in different techniques, as electro-fusion sockets, butt fusion technique, rubber ring (push fit) sockets, and flanged connections which are all applicable for HDPE drainage pipes and fittings.

Electro-Fusion Sockets

This technique is the ideal jointing method on-site, specifically suitable for installations in tight spaces like mechanical shafts. The process is easy and fast resulting in reliable connections. Electro-fusion couplings are used in this process, which are available in sizes from \varnothing 40 to 250 mm.



Rubber Ring Sockets

This technique is the ideal solution for compensation of thermal expansion in PE pipes. Rubber ring joints are not resistant to tension forces.



Flanged Connection

The conventional connection technique connecting HDPE pipes with pipes of other materials like metal and uPVC and for connections to tanks and equipments. Flanged joints are resistant to tensile forces.

This technique is very rarely used in above-ground drainage installations.



Butt Fusion

This technique is the ideal way for space-saving connections. Semi or fully automatic welding machines are utilized to achieve butt-fusion connections.



In this technique, both pipe ends are pressed against a hot plate at a constant temperature and pressure. Then pipe ends are pressed on head to head situation so that both pipe ends are fused together.

Light weight **manual butt fusion machines** are suitable for on-site installations



More sophisticated **automatic butt fusion machines** are utilized for bigger dimensions from 50mm to 315 mm. These machines are suitable for fusing prefabricated connections away from the site.

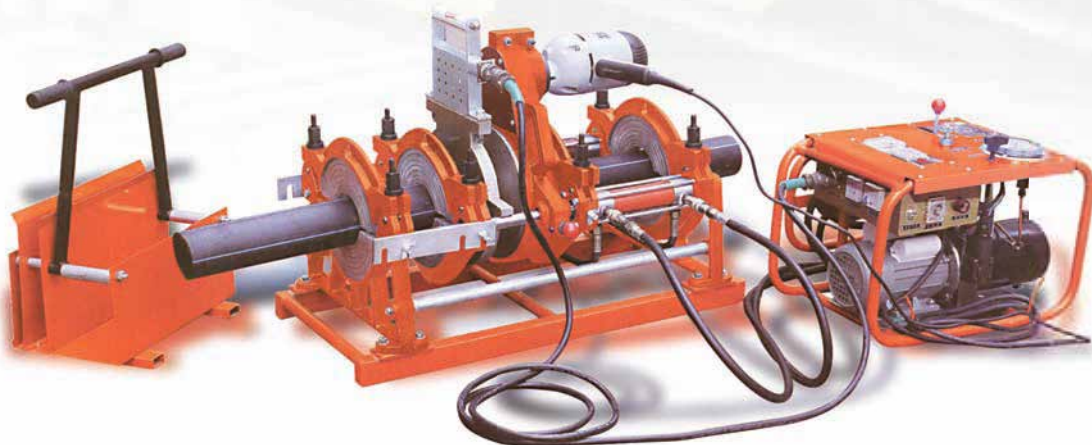

Pipe Supports and Clamping



- All pipework must be adequately supported whether vertical or horizontal.
- Plastic pipework expands and contracts with changes in temperature - whether ambient temperature or from the nature of the discharge through the pipework. Expansion joints must therefore be provided to accommodate such thermal movement.
- Pipe brackets must be used to anchor expansion joints. Intermediate support must also be provided to steady pipework between the points.
- Horizontal pipework requires more frequent support than vertical pipework (for example, soil stocks)
- On long suspended soil pipe runs (e.g. in basement areas), sliding joints should be installed to control the effects of thermal expansion.
- Pipework should always be supported close to any change of directions (e.g. bends or branches)
- Cosmoplast HDPE drainage pipes and fittings should be installed tension free and with free lateral allowance for thermal expansion compensation.
- Long runs of pipes should not be used in exposed installations unless some precautions are considered to ensure that excessive deformations will not occur in the system due to thermal expansion.
- Suitable sound absorbing brackets with rubber lining should be used to support pipes. Those brackets must be dimensionally compatible to the pipe diameter.
- The fixed bracket creates fixed point in the pipe system. With fixed brackets the pipe or fitting can not be moved through the bracket after screws are tightened. In order to prevent sliding down of vertical pipes, each individual pipe must be secured on one point by a fixed bracket.
- Fixed brackets must be installed directly above the fitting at the bottom of the pipe end. The sliding bracket must be installed at a distance of maximum of two meters above the fixed bracket.
- Every horizontally installed pipe should always be fixed with one fixed bracket. All remaining pipe brackets in horizontal as well as in vertical installation must be tightened in such a way to allow sliding.

- During installation of horizontal pipes, the distance between brackets should be approximately ten times the outside diameter of the pipe. While for vertical installations, brackets are required every 1 to 2 meters depending on the size of the pipe.
- In general, each expansion socket should be fixed with one fixed point bracket.
- The distance between the pipe and the structure to which it is fixed should be kept as small as possible in order to reduce the movement of the connecting rods.
- Pipe brackets should not be installed in areas of diameter reduction and change of directions in the system, this is required to allow for thermal expansion.
- Pipe brackets should be fixed on building materials with high strength in order to assure strong and durable pipe fixing.
- In multi-storey buildings, the drainage pipes of diameter 110mm or bigger installed inside the mechanical ducts must be secured by additional fixing against sliding.

Traps

Traps are essential for every discharging unit (wash basin, shower, sink,...etc) in the system. They are required to prevent bad smell from leaking inside the house.

Trap size should be suitable for the discharging unit to which it will be connected, as small traps will cause slow discharge and may cause self-siphoning in addition to the noise generation.



Oversized traps will reduce the flow speed in the trap which makes it difficult to flush the soiling and therefore may cause blockage.

HDPE Aerator

Cosmoplast HDPE Aerator with its unique design, enables the reduction of waste speed inside the stacks.



Advantages and characteristics of Cosmoplast Aerator:

- Reduces the speed of waste inside stacks.
- Eliminates the negative effect of pressure fluctuations inside the stacks.
- Suitable for high rise buildings (with more than 7 floors) and for applications with high sewage flow rates.
- Increases the flow rate in the waste stack by 40 – 50%.
- Prevents the return flow from the stack to the branches.
- Can be used with HDPE, or with PE and PVC stacks when using the special snap sockets.

The utilization of Cosmoplast Aerator in the drainage system increases the flow rate of waste inside the stacks significantly compared to the systems without aerators.

Maximum flow rate in stacks:

	Maximum Flow Rate (l/s)	
	110mm Stack	160mm Stack
Stack without Aerator	4.0 - 5.5	9 - 12.5
Stack with Aerator	7.8 - 8.1	18.0 - 18.2

The operation of the Aerator:

Cosmoplast Aerator with its unique design prevents the direct contact between the waste in the branches and the waste falling from the upper floors. This process prevents the negative effect of pressure fluctuations in the drainage system.

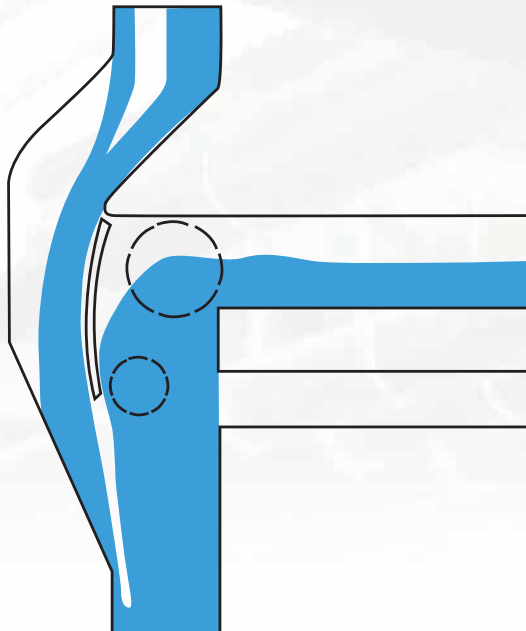

Installation of Cosmoplast Aerator:

Cosmoplast Aerator can be installed at every floor or every number of floors depending on the design conditions.

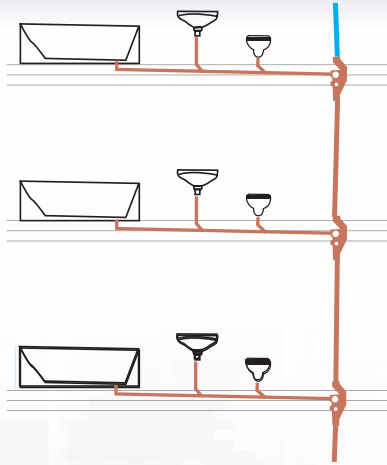

Cosmoplast Aerator has 2 front connections and 4 side connections, all can be used simultaneously. Installations which enables cross flow are not allowed and should not be used, as demonstrated in the below sketches:

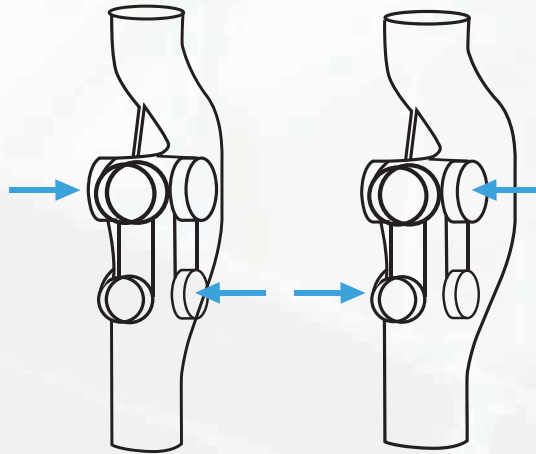

The maximum distance between two Aerators is recommended not to exceed 6m. However, in case of installations with distances more than 6m, it is recommended to make speed reduction loop by using four 45° elbows as demonstrated in the below sketch:

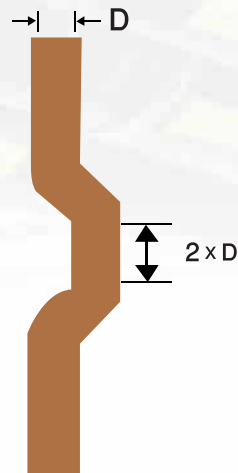

The vertical portion should be at least twice the diameter of the stack pipe.

Underground Installation

HDPE drainage pipes can be utilized in underground drainage systems. Trenches should be constructed and backfilling materials should be selected as per the local codes of practice. The below are some recommendations:

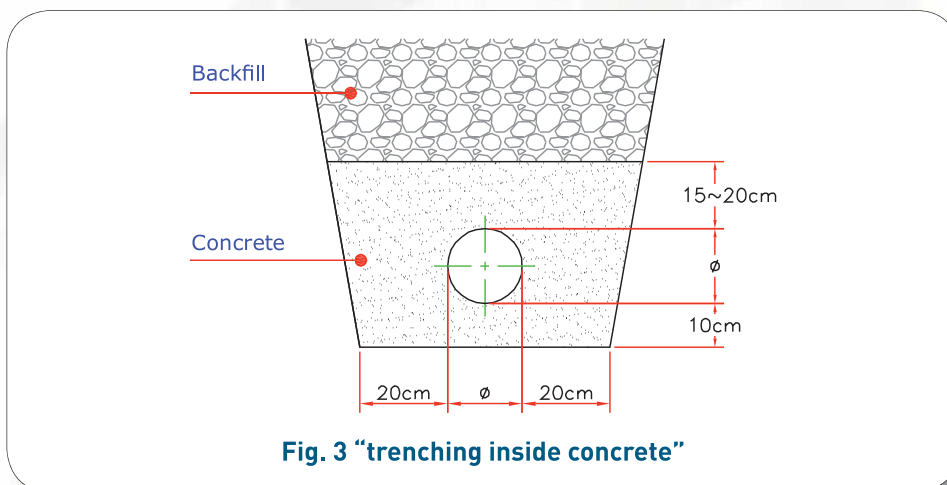
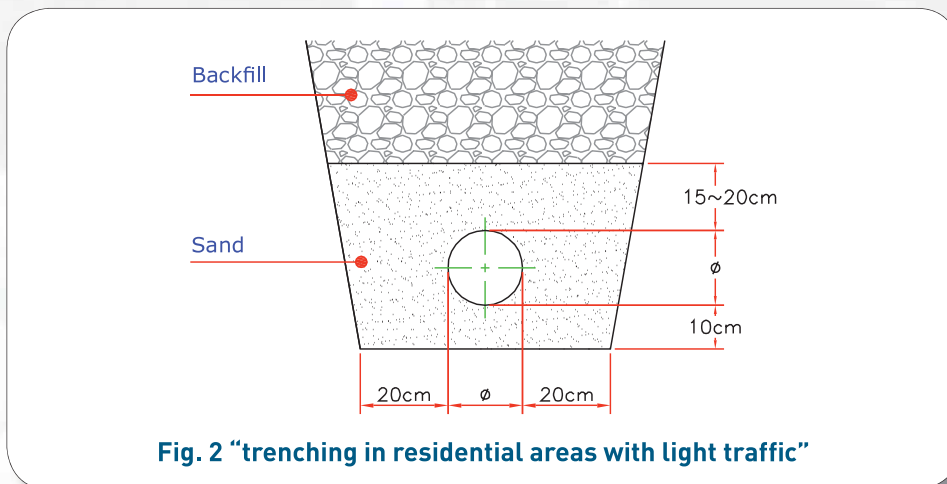
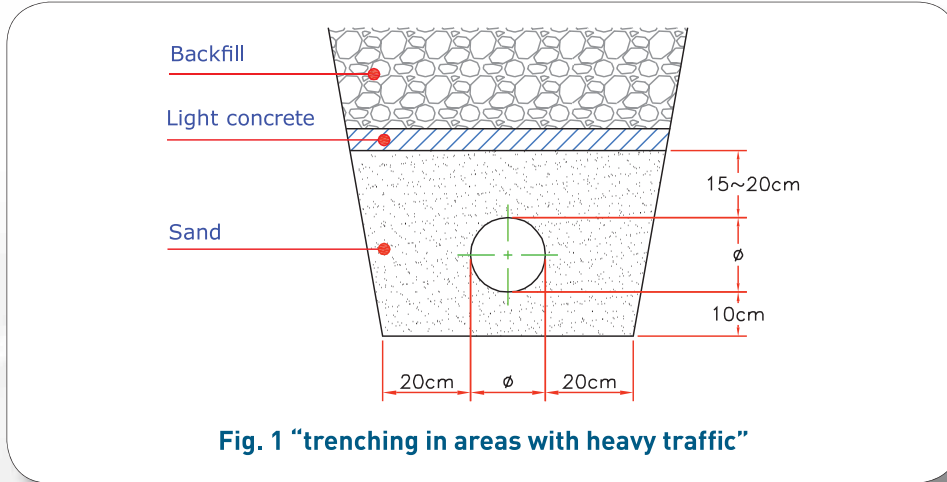

Recommendations for Backfilling:

- Place backfill as soon as the pipes have been bedded, jointed and inspected.
- Use granular material or selected backfill from the trench excavation free from
 1. Stones larger than 40mm.
 2. Clay lumps larger than 100mm
 3. Timber
 4. Frozen material
- Compact backfill in layers not deeper than 300mm
- Avoid mechanical compaction until fill is at least 450mm above pipe work

Handling, Storage and Transportation

HDPE drainage pipes and fittings should be handled with care considering the resilience of these pipes and fittings. Transportation, storage and handling should be done taking into consideration the below directions and precautions

Handling

- Take all reasonable care when handling HDPE, particularly in very cold conditions when the impact strength of the material is reduced.
- Do not throw or drop pipes, or drag them along hard surfaces.
- Do not scratch pipes against hard surfaces or drag them along the ground.
- In case of mechanical handling, use protective slings and padded supports. Metal chains and hooks should not make direct contact with the pipe.

Storage

- To avoid deformation over time, pipes should be stacked:
 - » either on a flat base
 - » or on a level ground
 - » or on 75mm x 75mm timber at 1m max. centers.

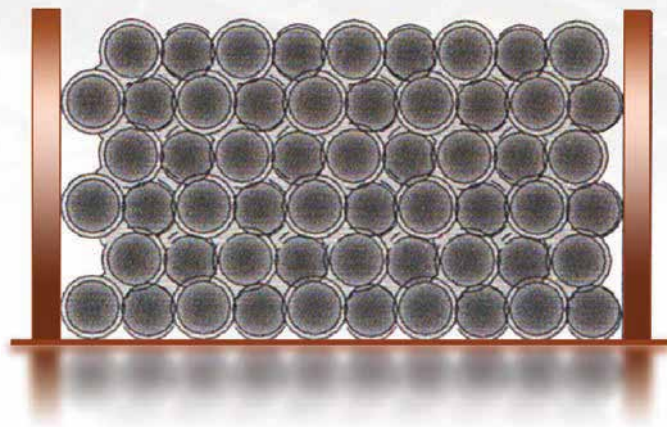

- Provide side support with 75mm wide battens at 1m centers.
- Maximum stack height is 1.7 meters regardless the pipe diameter.
- Store all materials in well-ventilated, shady conditions.
- Avoid direct exposure to sunlight for long periods.
- If stored in the open for long periods or exposed to strong sunlight, cover the stack with opaque sheeting.
- Keep fittings in original packaging until required for use
- Ideally, stacks should contain one diameter pipe size only. Where this is not possible, stack largest diameter pipes at base of stack. Small pipes may be nested inside larger pipes.
- Store fittings under cover. Do not remove from cartons or packaging until required.
- Do not place heavy items on top of the pipes.
- Protect the pipes from dirt, gravel or mud.
- Pipes should be kept clean as much as possible, as this may save cleaning time while preparing pipes for welding.
- Electro-fusion sockets should be stored indoors inside their original sealed packing to prevent oxidation from sunlight, which can badly affect the welding quality.



Transport

While transport, pipes should be arranged safely on trucks avoiding crossing, bending and over stacking. The pipes should also be fully supported over their total length.

Proper protection should be provided if chains or cords are used to tie down the load in order to avoid damaging the pipes.

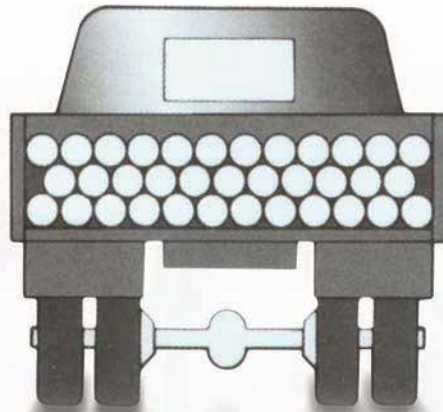

Installation: General rules and recommendations:

- Pipe sizing must be determined on a section by section basis.
- Collecting pipes must be straight and short as much as possible.
- Change of pipe direction should not be made at angles less than 45° to avoid soil being left behind.
- In any section, the sum of changes in direction should not exceed 135°.
- Eccentric reducers should be used in the horizontal collecting pipes.
- Concentric reducers should not be used on horizontal sections.
- Horizontal connections must be made with 45° Y branches.
- 90° top connections must be avoided when the horizontal pipes are smaller than 110mm as top connections may cause flow disturbance and hydraulic sealing in the horizontal pipes.
- Stacks should be designed in such a way to prevent hydraulic sealing or excessive pressure differences at the points of connections with collecting pipes and bends including the points at the foot of the stacks when connecting to the underground pipes.
- HDPE aerators should be used every 3- 4 stories to ensure better ventilation in the stacks.
- Stacks should be as straight as possible.
- The diameter of the stack should not be smaller than that of any of the collecting pipes connected upstream.
- Connections to the stack should be at right angles to prevent hydraulic sealing in the collecting pipes.
- The length of offset stack sections should not exceed 1.50 m.
- The diameter of ventilations pipes should be the same as stack diameter.
- To avoid sewage smell entering the building, the top of the vent pipe must be at least 1m above the highest point of air entry to the building.

Butt Fusion Process:

Fusion machine and equipments should be checked before starting the welding process.

The hot plate must be cleaned with alcohol and clean cloth to remove dirt and grease which may badly affect the welding quality.

The hot plate temperature should be 210° C.

The machine clamping brackets and the two pipe supports should be correctly aligned before starting the welding process. Alignment can be done by clamping single piece of pipe in both clamps and both pipe supports.

The clamping brackets must be adjusted to ensure that they hold the pipe tightly.

Oval pipe ends should be made round before welding, this can be done by clamping the pipe with one or more brackets and applying reasonable tension. These brackets should be removed after cooling the welding area.

Proper pipe cutter (preferably roller type) should be used to cut PE pipes to avoid creating burrs or sharp ends.



Procedure for Butt Fusion

Note: The installer should follow the manufacturer's instructions listed in the catalogue of welding machine.

- 1 The hot plate should be set up to the correct welding temperature.
2. Clamp the pipes with the machine.



3. Use the trimmer on the pipe ends until they no longer contact the blade.



4. Check the pipe ends and ensure that they match precisely. Clamp and trim the pipe ends again if necessary.



5. Move the heating plate to the correct position between the two pipe ends.



6. Press the pipe ends against the hot plate by applying high pressure.



7. Continue heating while applying low pressure until seam of at least 1 mm high has formed.



8. Remove the heating plate quickly.



9. Press the two pipe ends against each other and slowly increase the welding pressure. Refer to the machine manual for the appropriate welding pressure.



10. Maintain fixed welding pressure and leave the welded joint to cool.



11. Check the welded area to ensure that the seam is regular around the pipe circumference. Reject any defected joint.

Electro-Fusion Process

Electro-Fusion process is carried out using special welding machine and PE Electro-Fusion sockets.



The PE Electro-Fusion sockets are provided with 2 socket ends that can be welded in a single operation.

The Electro-Fusion sockets include built in resistance coil in their body, the welding machine sends current through the resistance coil that cause the PE material to melt and therefore the two sides of the socket and the pipes are fused together at the same time.

The electro-fusion sockets have stops on their internal surface up to which the pipe should be inserted inside the socket. These stops can be removed with sharp blade in case the electro-Fusion sockets are to be used as sliding couplers.

The electro-fusion sockets have two pins on the external surface, to which the welding machine is connected while performing the welding process. The two indicators will appear during the welding process to indicate that the welding temperature has been reached.

After performing the electro-fusion process, the internal surface of the socket and the external surface of the pipe will be fused together.

Quality electro-fusion joints are guaranteed only if the socket and pipe surfaces are free from moisture, dirt, grease and oxidation.

PE material forms oxidation layer during production and storage which must be removed before welding. The oxidation layer can be removed by cutting, scraping in combination with cleaning.

The electro-fusion welded joints should not be subjected to any load immediately after welding. They have to be left to cool before moving.

Preparing the joints for Electro-Fusion:

1. Select the correct size of electro-fusion sockets.
2. Ensure that the electro-fusion welding machine is suitable for the pipe diameter to be welded.
3. Ensure that the voltage is appropriate for the welding machine.
4. Ensure that the pipe ends are square cut, free from burs and are not oval.
5. In large installations, it is recommended to seal the pipes with protective caps to avoid rapid excessive cooling resulted from streams of air that may be flowing through the pipe.
6. In case of humid atmosphere, pipe ends and sockets should be heated to remove moisture.

Procedure for Electro-Fusion:

Note: The installer should follow the manufacturer's instructions listed in the catalogue of the used welding machine.

1. Insert the two ends to be welded in the electro-fusion socket.



Note: The two fused ends should be fully inserted inside the electro-fusion socket until they reach the stopper at the middle of the socket. Incomplete insertion may cause the joint to fail or leak.

2. Connect the machine to the power.
3. Connect the machine connector cables to the electro-fusion socket.



4. Press the machine start button.
5. Keep the joint connected to the machine until the welding indicator lamp extinguishes and the socket pins appear by about 2 mm.



6. If the welding process is interrupted, rectify the interruption reason and allow the joint to cool completely then repeat the entire procedure.
7. Allow the joint to cool for few minutes before applying any load on the joint.

Rubber Ring Joints

The rubber rings must be kept clean and free from solid dirt and dust. The pipes should be square cut, deburred and chamfered at around 30° .

Apply Cosmoplast recommended joint lubricant to the rubber ring.

Insert the pipe inside the rubber ring joint until it reaches the internal stops.

Align the pipe and the socket correctly at both sides of the socket.

Protect vertical joint from dirt and construction material during installation by applying sealing tape.



Testing HDPE Drainage Systems

Air Test

Pipeworks can be Pressure tested using air under low pressure. This is carried out by closing all openings with pressure test plugs, then applying air pressure of 0.2 to 0.3 bar (0.2 to 0.3 meter of water column). Soapy water should be applied at the joints to detect any possible leak.

Leaks (if found) should be repaired and the pressure test should be repeated until the system passes the test successfully.

Pipework casted in concrete should be tested before casting the concrete to ensure that all joints are watertight. Repairing leaks after casting concrete will be very difficult and costly.

Water Test

- All pipe ends and connections must be plugged using suitable testing plugs.
- Install vertical pipe length to the drain to provide the necessary testing water head.
- Fill the system with water to maximum height of 3m (30 kPa).
- The maximum head at the lower parts of the system should never exceed 4.0m, therefore in case of steep gradients the system should be tested in sections.
- The filled system should be left 2 hours under testing, during which the system should be inspected by measuring the drop in water height.
- The pipe work should be inspected for any leakage and all defected installations should be repaired and tested again.



System Maintenance.

Periodical tests and maintenance of drainage systems is essential to ensure proper operation of the system. In case of blockages not located in the traps, cleaning by using spring of water or high pressure jet can be used. Extra care should be taken to avoid damages particularly in bends.

Special drain-clearing liquids are available in the market and can be used by following the instructions on the containers.

Access Fittings

Access fittings should be installed at proper accessible locations in the system to enable cleaning and discharging any blockage that may occur in the system due to solid deposits.



These access fittings enable the insertion of cleaning hoses and springs whenever blockage occurs.

Access fittings are recommended to be installed at locations higher than the discharge level of the fittings, so that the blocked section will not discharge through the access fitting once the cap is opened.

Access Pipes are recommended to be installed on the below locations:

1. On stack pipes at every 3 to 4 stories (15m) to enable multiple access points to the stack and allow the whole stack to be cleaned if needed.
2. At the points of connection between underground and above ground pipework.
3. After pipework sections that include multiple bends and long pipe runs.
4. On pipeworks which are casted in concrete.

Chemical Resistance of HDPE

The HDPE material has a high resistance to a wide range of chemical which makes the HDPE as an ideal option for many residential and industrial applications.

Detailed tables for the chemical resistance of HDPE material can be provided upon request.

Expansion of PE Pipes:

Plastic materials have relatively high coefficient of thermal expansion (for PE it is 0.18mm/m°C). PE pipes will expand and contract with temperature variations.

Temperature variations may also occur during construction from high temperature in the sun to low temperature in winter.

Temperature variations also occur during system operation due to the varying temperature of the discharged water and of the environment. Temperature variation of 40°C may be adopted as a maximum mean temperature difference in the connecting collecting pipes in the aboveground drainage. While 20°C temperature variation can be adopted for stacks and underground pipes.

Temperature variation of 60°C may be adopted in areas of hot water discharge.

Expansion sockets should be implemented to absorb expansion in PE pipes.

Expansion Sockets

Expansion sockets must be installed in the pipework at suitable locations so that the change in pipe length resulted from thermal expansion is absorbed inside the expansion sockets.

Pipe clamps are used as fixed points at the expansion sockets above which the pipe should be left free to expand and contract.

Expansion sockets are recommended to be installed on every storey, in which case the floor of each storey serves as fixed point.

Expansion sockets are recommended in vertical installations to avoid the risk of fouling accumulation between the socket and the pipe in horizontal installations.

While installing expansion sockets, pipes should not be fully inserted in the socket up to the stop end, this is essential in order to allow the pipe to expand and contract inside the socket.

During installation, expansion sockets should be sealed with tape to avoid dirt and cement entering between the socket and the pipe during construction.



Rigid installation

When PE drainage pipes are installed in concrete, the expansion and its resulted force will be transferred to and absorbed by the building structure.

Welded joints must be allowed to cool, pressure tested and checked for leak before casting in concrete.

EXPANSION SOCKET FIXING TECHNIQUES

Use

An expansion socket is a rubber ring socket that is connected to the pipe runs to accommodate the pipe expansion / contraction resulted from temperature variation. It is recommended between anchor brackets when excessive thermal movement is anticipated.

At least one expansion joint should be installed on vertical stacks, on long collector pipes, and at the point of connection to the underground drainage network.

Installation

The expansion sockets are installed on vertical and horizontal pipelines. Fixing bracket must be installed behind the expansion socket to avoid any movement of the socket in the event of expansion or contraction.

Recommendations to achieve perfect expansion joint:

- Chamfer the pipe end to approximately 15°.
- Ensure that the pipe is not fully inserted in the expansion socket in order to allow the expansion / contraction of the pipe.
- Mark the correct insertion depth on the pipe.
- Use sufficient quantity of water base lubrication on the pipe and rubber ring.

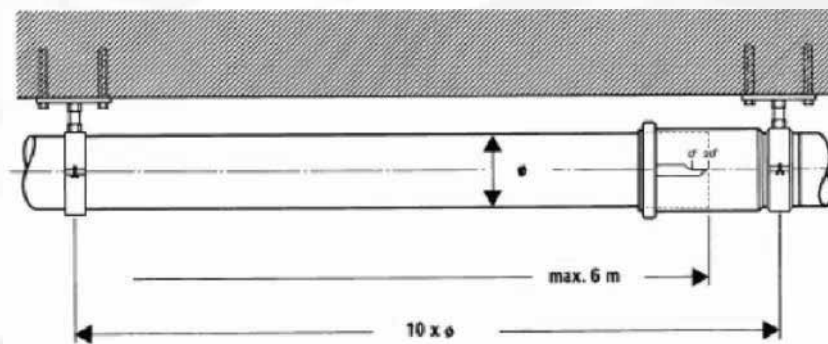
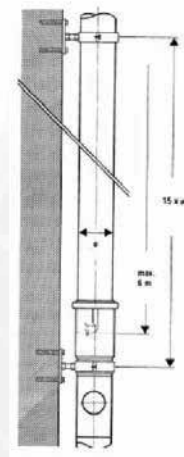

Expansion in HDPE Pipes

Thermal Expansion:

The thermal expansion of PE pipes resulted from the temperature variation is usually compensated using expansion sockets.

The axial expansion of the pipe can be calculated using the below formula :

$$\Delta l_t = L_{\text{pipe}} \cdot \alpha t \cdot t_{\text{max}} \cdot 10^3$$

Where :

Δl_t = length change (mm)

L_{pipe} = total length of pipe (m)

αt = linear expansion coefficient (mm/m°C) = 0.18 mm/m°C

t_{max} = temperature difference in °C

Or can be taken from the below diagram:

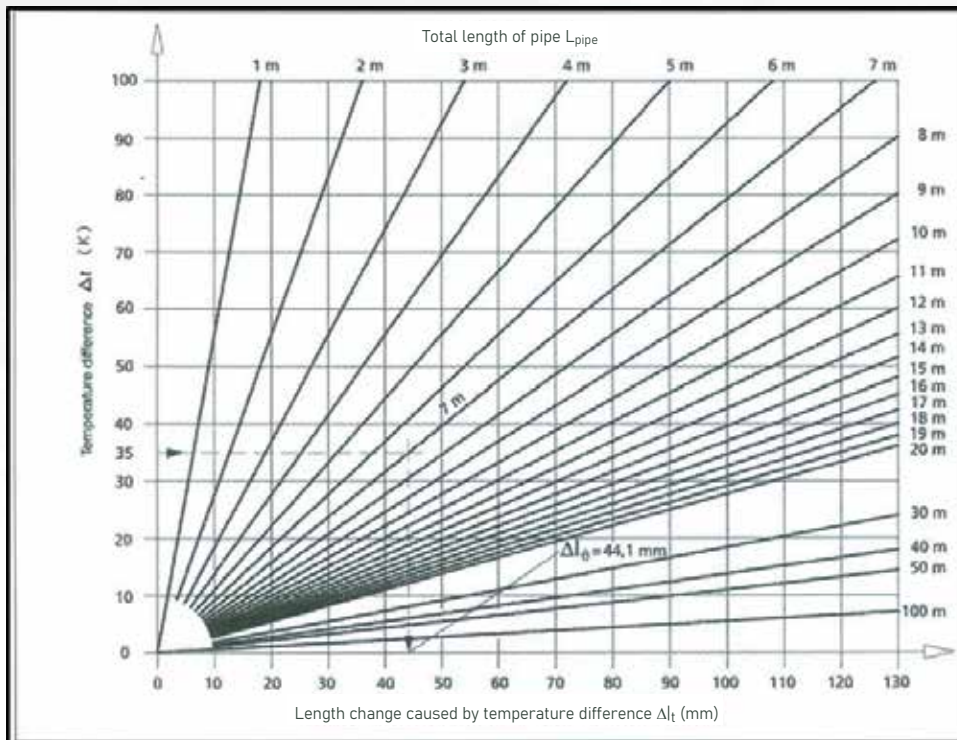

Compensation of Thermal Expansion:

The expansion socket can usually take around 55mm of the pipe expansion.

In general, every expansion socket can accommodate the expansion and contraction of a 6 meter pipe. Therefore in every pipe section the required number of expansion sockets have to be estimated and installed. As demonstrated below:

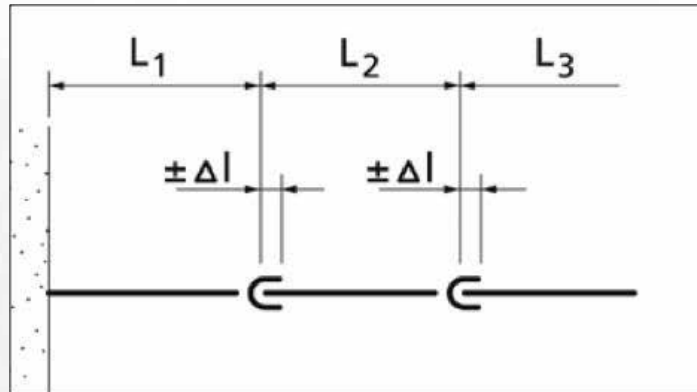

Example:

Total length of pipe section : $(L_1 + L_2 + L_3) = 20\text{m}$
 Temperature during installation : 25°C
 Temperature variation : $+15^\circ\text{C} / +60^\circ\text{C}$
 Temperature difference : $60 - 25 = 35^\circ\text{C}$
 Total expansion : $20 \times 0.18 \times 35 = 126.00\text{mm}$

Therefore considering that every socket can take about 55mm of length variation, this results results in $126/55 = 2.29$ sockets. Therefore 3 sockets should be used to compensate the expansion / contraction in this pipe section.

Free Pipe Length:

The length variation due to longitudinal expansion should be compensated by a calclated and planned change of direction.

The free pipe length L_b is the length of pipe that should be kept free without clamping in order to compensate the expansioin.

The following formula can be used to estimate the Free Pipe Length:

$$LB \geq 10 \times \sqrt{\Delta l \times d_{1,2}}$$

LB : Free Pipe Length
 d1 : Pipe Diameter
 Δl : Longitudinal expansion

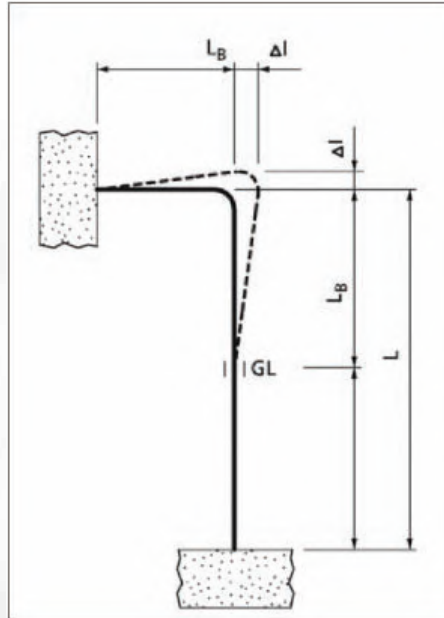

Where :

LA= Bracket distance
 LB= Length deflection leg
 L= Pipe length
 GL= Sliding Joint
 Δl = Length change

PRODUCT RANGE



Polyethylene Pipes and Fittings for Drainage Applications
according to BSEN 1519.

HDPE Drainage Pipes:



Nominal Outside Diameter (mm)	Length (m)	Wall Thickness (mm)	
		SN4/SDR26	Series S 12.5
32 *	5.0 / 5.8	3.0	
40 *	5.0 / 5.8	3.0	
50	5.0 / 5.8	3.0	
56 *	5.0 / 5.8	3.0	
63 *	5.0 / 5.8	3.0	
75	5.0 / 5.8	3.0	
80 *	5.0 / 5.8	3.1	
90 *	5.0 / 5.8	3.5	
110	5.0 / 5.8	4.2	
125 *	5.0 / 5.8	4.8	
160	5.0 / 5.8	6.2	
200	5.0 / 5.8	7.7	
250 *	5.0 / 5.8	9.6	
315 *	5.0 / 5.8	12.1	

Sizes 80mm & larger are produced in S 12.5 & S 16

* Upon request with feasible quantity.

45° Elbow



Size (dn)	L mm
40	40
50	45
75	50
110	60
160	69
200	103
250	170
315	170

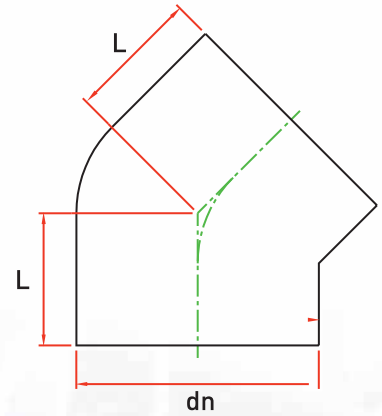

91.5° Elbow (Suitable For Butt Fusion & Electro Fusion)



Size (dn)	L mm
40	55
50	60
75	75
110	95
160	120
200	174
250	215
315	252

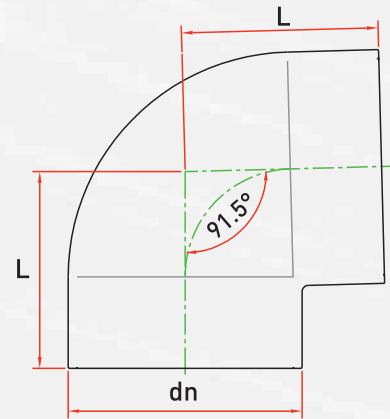

91.5° Elbow (Suitable For Butt Fusion & Electro Fusion)



Size (dn)	L1 (mm)	L2 (mm)
50	40	180
75	70	210
110	100	270

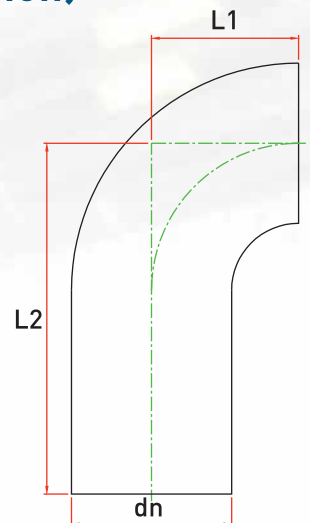

90° Waste Elbow

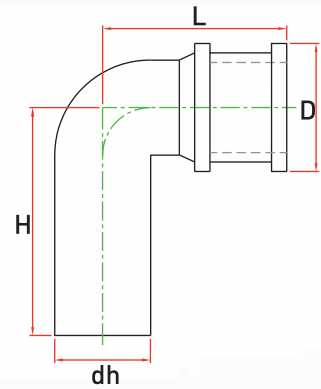

Size (dn)	D (mm)	L (mm)	H (mm)
50	58	57	90

45° Y Branch

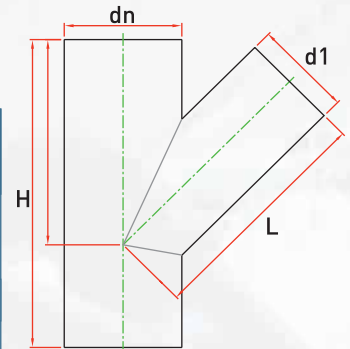

Size (dn x d1 x dn)	H mm	H1 mm	L mm
40x40x40	135	90	90
50x40x50	165	110	110
50x50x50	165	110	110
75x50x75	210	140	140
75x75x75	210	140	140
110x50x110	270	180	180
110x75x110	270	180	180
110x110x110	270	180	180
160x75x160	375	250	250
160x110x160	375	250	250
160x160x160	375	250	250
200x110x200	355	273	258
200x160x200	426	115	311
200x200x200	540	360	360
250x160x250	436	358	346
250x250x250	450	415	400

91.5° Swept Tee Branch

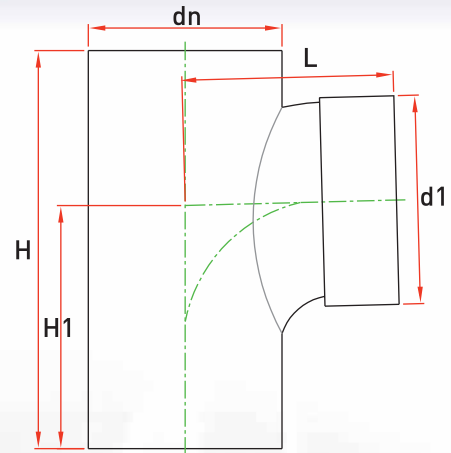

Size dn x d1 x dn	H mm	H1 mm	L mm
40x40x40	130	75	55
50x50x50	150	90	69
75x50x75	170	102	81
75x75x75	170	98.5	85.5
110x50x110	225	135	99
110x75x110	225	135	104
110x110x110	225	135	115
160x110x160	245	140	130
160x160x160	284	155	131

45° Access Pipe

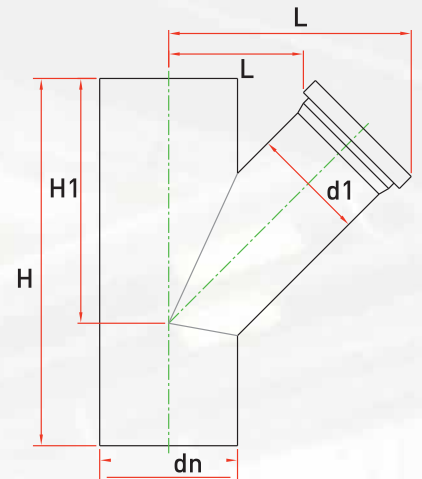

Size (dn)	H mm	H1 mm	L mm
50	145	100	130
75	190	130	180
110	270	180	195

90° Access Pipe



Size (dn)	H mm	H ₁ mm	L mm
50	136.5	82	81.8
75	168.5	95	93
110	227	128.5	116
160	350	210	150
200	477	340	300

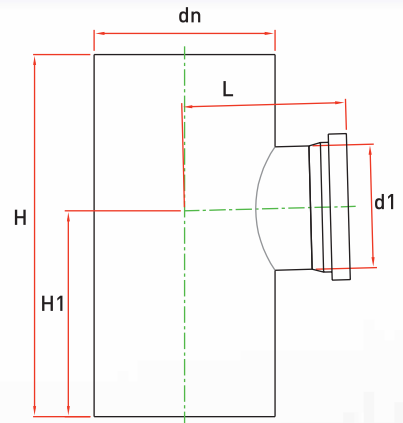

Access Plug



Size (dn)	D (mm)	L1 (mm)	L2 (mm)
50	72	41	23.5
75	99	48	26.5
110	140	52	33

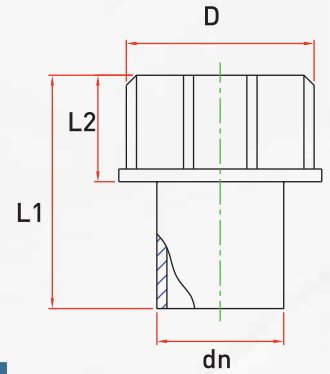

HDPE Floor Trap with Push Fit Inlets & Outlets



75 mm Water Seal

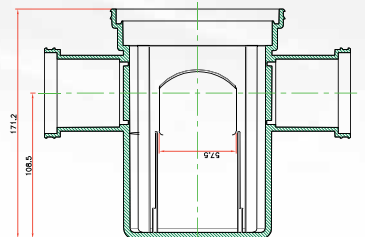
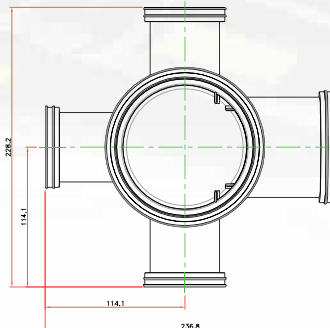

D (mm)	D1 (mm)	D2 (mm)	H (mm)	H1 (mm)	H2 (mm)	L (mm)
110	75	50	171.3	108.5	72.5	228.2

4 Way HDPE Boss Pipe

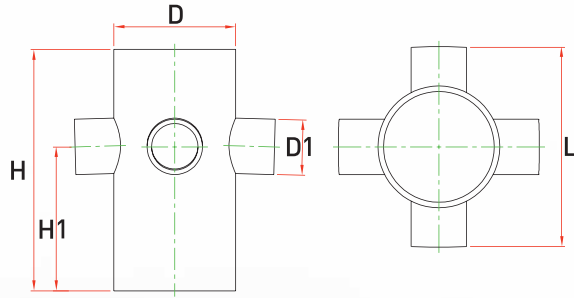

D (mm)	D1 (mm)	H (mm)	H1 (mm)	L (mm)
110	50	218	130	180

Floor Drain

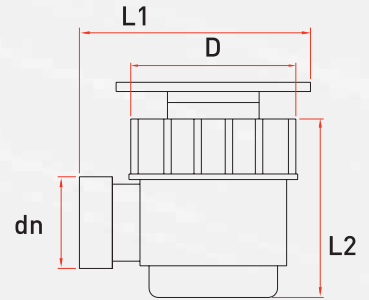

Size (dn)	D (mm)	L1 (mm)	L2 (mm)
40	90	130	87.3

Eccentric Reducer



Size d x d1	H mm	H1 mm	H2 mm
50x40	80	37	35
75x50	80	37	35
110x50	80	37	35
110x75	80	37	35
160x110	80	37	35
200x110	195	105	65
200x160	166	55	45
250x160	195	105	65
250x200	245	110	110
315x200	260	110	120
315x250	260	110	120

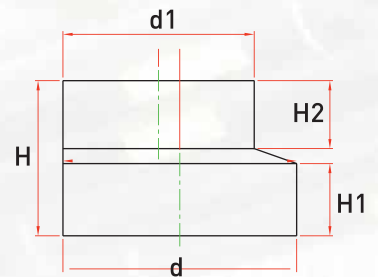

Concentric Reducer



Size (dxd1)	H (mm)	H1 (mm)	H2 (mm)
200x160	22.1	90	80
250x200	23.8	100	100
315x200	30.2	150	100
315x250	31.8	150	110

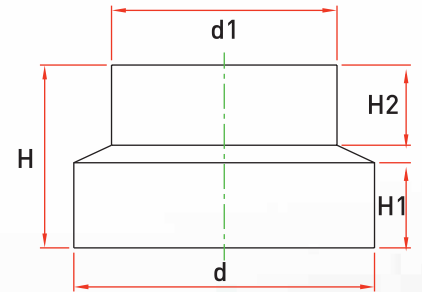

91.5° Double Ball Branch



Size (dnxd1xdn)	D (mm)	H (mm)	L (mm)
110x50x110	170	120	137
110x75x110	170	120	137
110x110x110	170	120	137

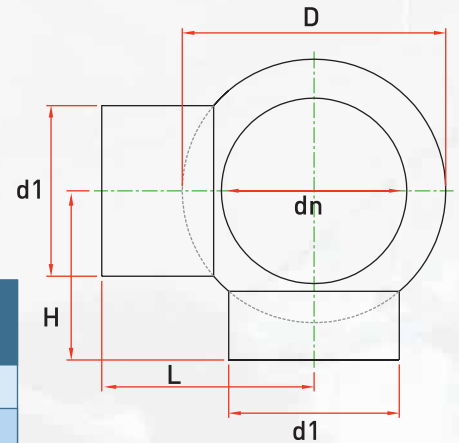

135° Double Ball Branch



Size (dnxd1xdn)	D (mm)	H (mm)	L (mm)
110x50x110	170	120	137
110x75x110	170	120	137
110x110x110	170	120	137

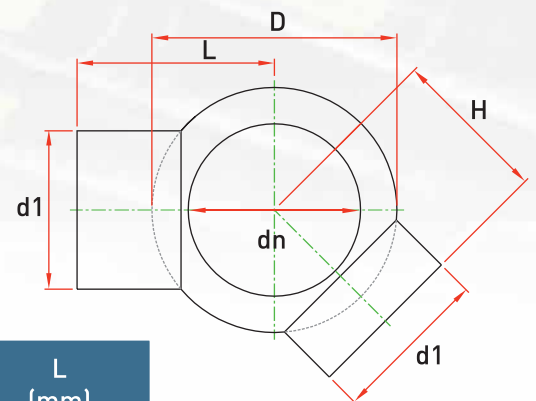

180° Double Ball Branch

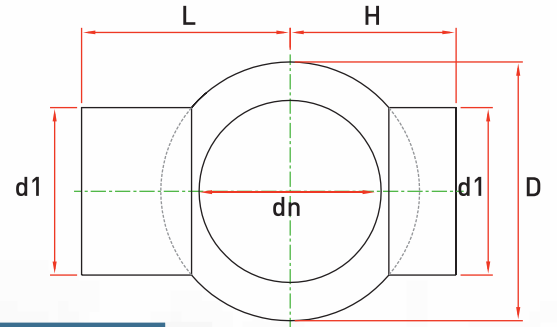

Size (dnxd1xdn)	D (mm)	H (mm)	L (mm)
110x50x110	170	120	137
110x75x110	170	120	137
110x110x110	170	120	137

Electrofusion Coupler

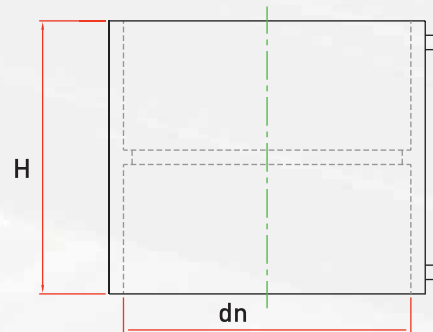

Size (dn)	H (mm)
40	60
50	60
75	60
110	70
160	80
200	120
250	125
315	135

Expansion Socket



D (mm)	D1 (mm)	H mm
50	57	233
75	82	233
110	119	245
160	178	246
200	220	261

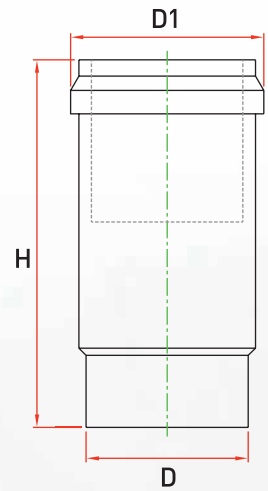

Rubber Extension Ring Socket



D (mm)	D1 (mm)	H (mm)
50	58	63
75	82	72
110	121	85
160	160	135

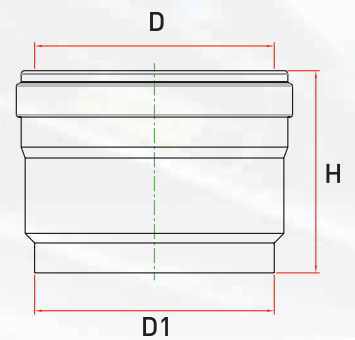

Vent Cowl



D (mm)	H (mm)
75	70
110	84
160	105

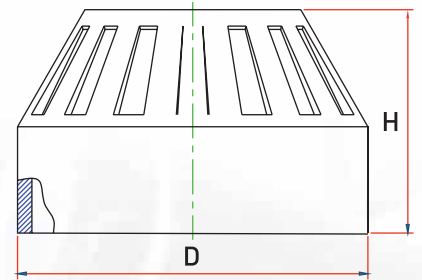

Aerator (Speed Breaker) with Plain Ends

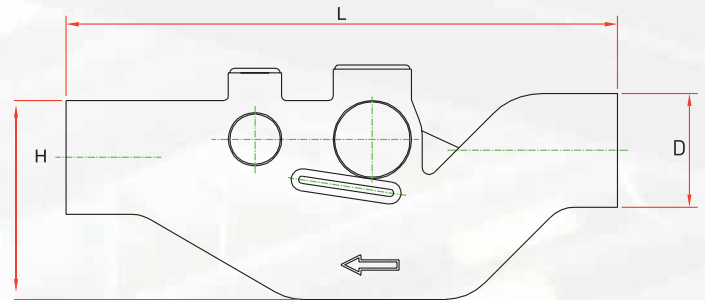

D (mm)	H (mm)	L (mm)
110	240	760
160	280	775

Aerator (Speed Breaker) with Rubber Ring Socket:

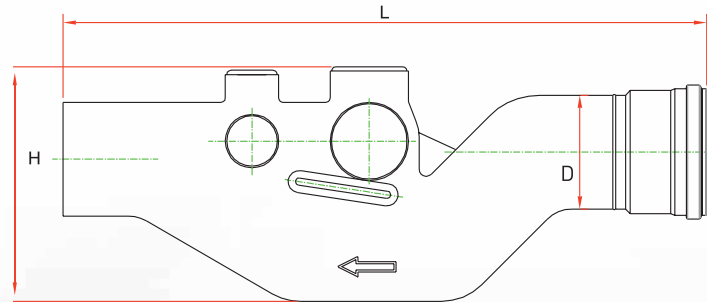

D (mm)	H (mm)	L (mm)
110	270	850
160	280	900

Anchor Pipe



Size (dn)	H (mm)	h (mm)	h1 (mm)
110	87	30	6
160	90	30	7
200	140	47	15
250	200	47	20
315	200	41	20

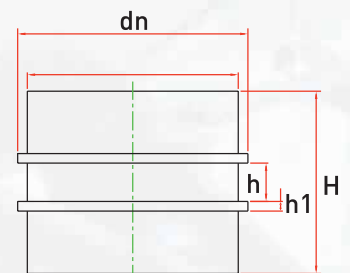

Flange Adapter



Size (dn)	D (mm)	L (mm)	H (mm)
75	121.5	14	91.7
110	150.7	9	101.5
160	198	18	62.5

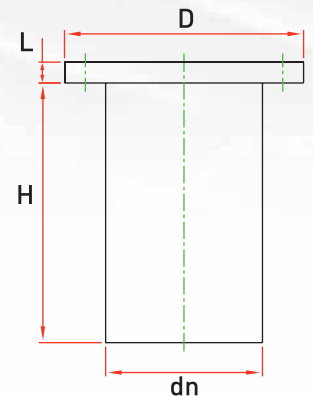

GI Flange Ring



Size (dn)
75
110
160

U Trap



Size (dn)	D (mm)
50	75
75	112
110	160

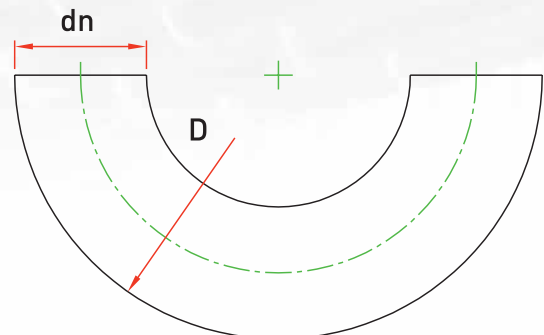

P Trap

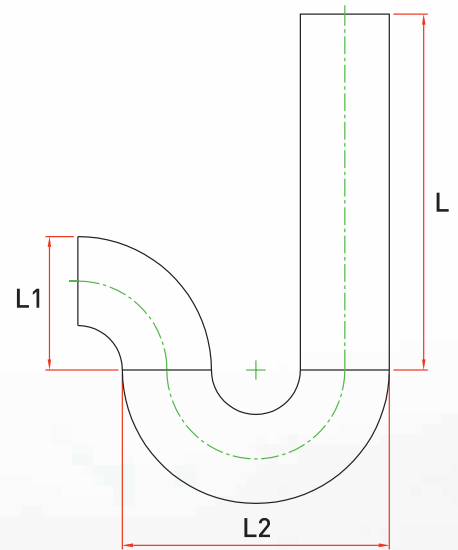

Size (dn)	L (mm)	L1 (mm)	L2 (mm)
50	180	70	170
75	180	108	253
110	180	150	360

Automatic Electro-Fusion Machine



Manual Butt Fusion Machine



Handheld Heating Element



HDPE PUDDLE FLANGE

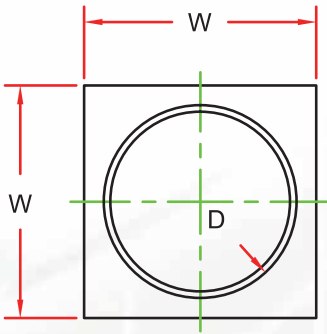

TOP VIEW

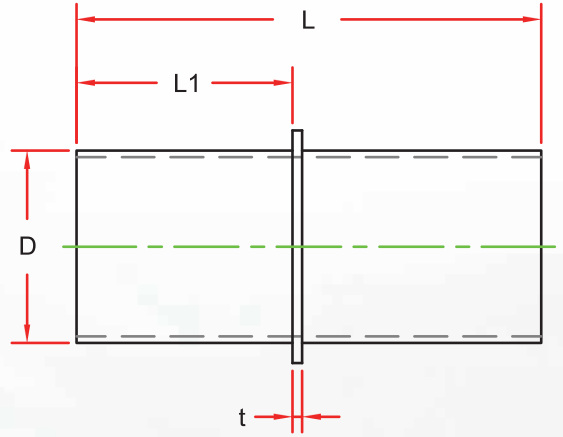

FRONT VIEW

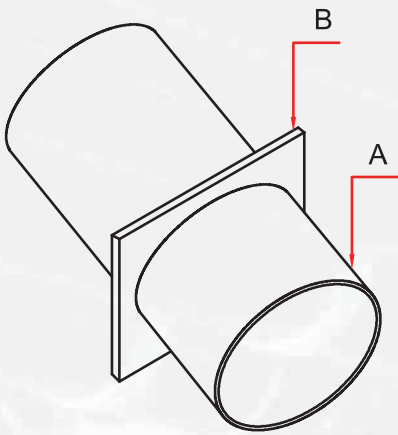

ISOMETRIC VIEW

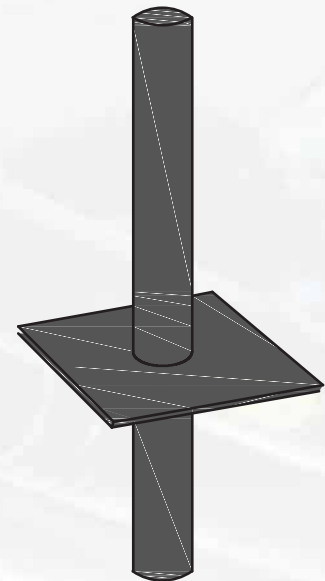

Note: The dimensions can be altered to suit specific requirements

SYSTEM WARRANTY

Cosmoplast HDPE drainage pipes and fittings are subjected to continuous tests during production in order to guarantee high quality and reliability.

Cosmoplast Industrial Co. LLC guarantees that its HDPE Drainage Pipes & Fittings are free from manufacturing and material defects.

In witness hereof, Cosmoplast issues this warranty for its system of HDPE Drainage Pipes and Fittings which shall be valid for a period of ten years starting from the date of installation.

However, Cosmoplast will not accept, and will not be held liable or responsible for damage to these products, or any consequential losses under the following conditions:

1. If working conditions are different than those prescribed in this catalogues.
2. If the components are used in installations where the fluid is not compatible with the material as per the related international standards.
3. If the components present defects when installed, due to incidental factors easily recognizable at the time of installation or when the system is submitted to pressure test.
4. If Cosmoplast components are installed with other items not manufactured by Cosmoplast.
5. In case of poor or inappropriate storage.
6. In case of poor or inappropriate installation, use or operation.

Warranty Coverage:

This Warranty is limited only to the replacement of the material with manufacturing defects. Cosmoplast will not be liable for any direct or indirect consequential losses or damages.

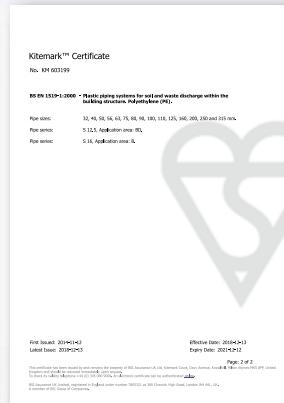

Inline with our product development programme, Cosmoplast reserves the right to modify or change any of the information contained herein without prior notice.

Pipeline Systems

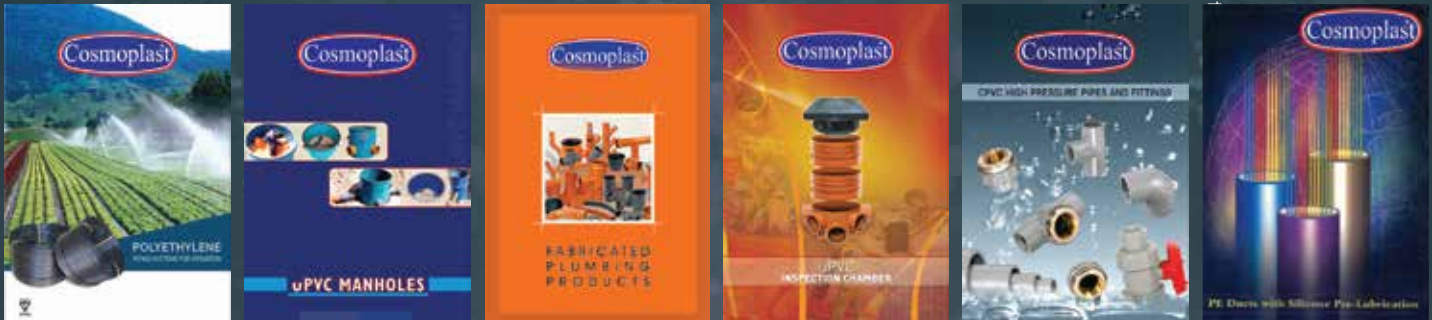

www.cosmoplast.com

Cosmoplast Industrial Co. LLC

Sharjah

Sales Off. Tel: +971 6 5331212
 Fax: +971 6 5331917 / 5332901
 P.O.Box: 6032

Dubai

Tel: +971 4 8850500
 Fax: +971 4 8850700
 P.O. Box: 50488

Abu Dhabi

Sales Off. Tel: +971 2 5515364
 Fax: +971 2 5515365
 P.O. Box: 8593

Saudi Arabia-Riyadh

Tel: +966 11 265 4501
 Fax: +966 11 471 4669
 Email: pipeline@interplast-ksa.com

Qatar-Doha

Tel.: +974 44687881/2
 Fax: +974 44687886
 Email: info@harwalqa.com

Email: pipeline@cosmoplast.com

