



Polypropylene Random (PP-R) Piping System for Hydro-Sanitary Applications



الهيئة السعودية للمواصفات والمقاييس والجودة
Saudi Standards, Metrology and Quality Org.



* Please refer to certificates for details

Cosmoplast, a primary member of Group Harwal, has been at the forefront of the plastic industry in the Gulf region since its founding in 1976. Through constant growth and product diversification, the company continues to be the largest thermoplastic pipe manufacturer in the region.

Continuously enhancing its capabilities in plastic manufacturing technologies, Cosmoplast now utilizes a diverse range of materials such as uPVC, polyethylene (HDPE, MDPE, LDPE, LLDPE), cross linked polyethylene (PEX), random copolymer polypropylene (PP-R), CPVC and RTP.

Cosmoplast's ongoing research and development programs continue to add new products to its pipeline systems product range that now includes pre-insulated pipes, reinforced thermoplastic pipes, specialized plumbing systems and fabricated uPVC and GRP manhole systems. Its state of the art engineering, design and tool room facilities are fully capable of manufacturing moulds, dies, machinery equipments and other specialized tooling requirements to meet the company's continual expansion and product development requirements.

With this extended product range, Cosmoplast's pipeline systems cater to an extensive range of market sectors and applications covering infrastructure development, plumbing, oil & gas, district cooling, irrigation, landscaping and water extraction.

An ISO 9001 certified company, Cosmoplast has its production facilities based in Abu Dhabi converting over 75,000 metric tons of plastic per annum. In addition to these, Cosmoplast also has facilities in Saudi Arabia, Moscow and Kaliningrad.

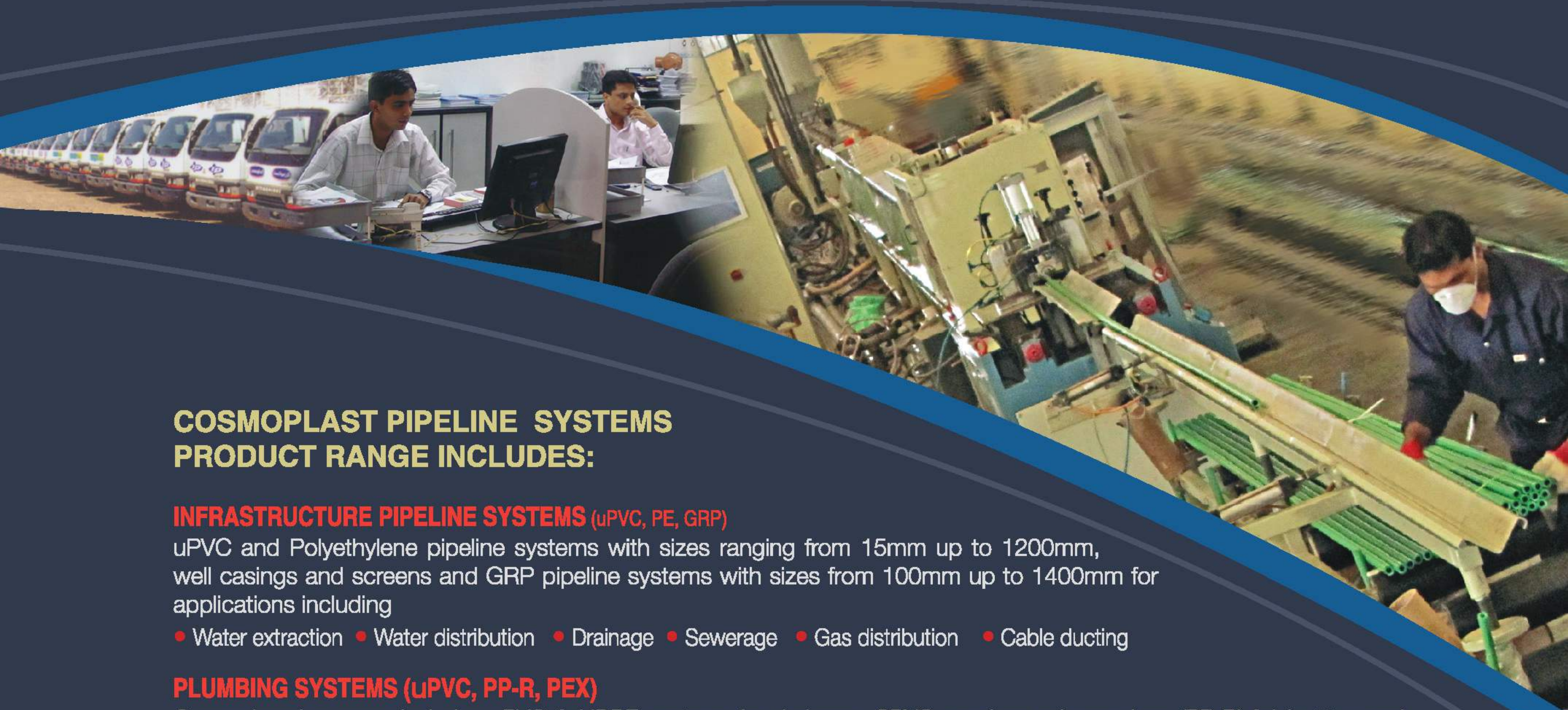

COSMOPLAST PIPELINE SYSTEMS PRODUCT RANGE INCLUDES:

INFRASTRUCTURE PIPELINE SYSTEMS (uPVC, PE, GRP)

uPVC and Polyethylene pipeline systems with sizes ranging from 15mm up to 1200mm, well casings and screens and GRP pipeline systems with sizes from 100mm up to 1400mm for applications including

- Water extraction
- Water distribution
- Drainage
- Sewerage
- Gas distribution
- Cable ducting

PLUMBING SYSTEMS (uPVC, PP-R, PEX)

Comprehensive range includes uPVC & HDPE systems for drainage, CPVC, random polypropylene (PP-R) [plain, fiber and aluminium composit] and cross linked polyethylene (PEX) systems for water and sanitary applications and uPVC high pressure pipes and fittings for water supply and A/C drain. Plumbing accessories such as pipe clamps, polyethylene compression fittings, solvent cement, lubricants and adhesives compliment this product range.

PRE-INSULATED PIPES (HDPE-HDPE, HDPE-GRP, HDPE-STEEL, GRP-HDPE, GRP-GRP, GRP-STEEL)

Jacket – core pipe combination with polyurethane insulation are used for applications such as District Cooling systems, Oil & Gas and other industrial applications. Cosmoplast provides HDPE and GRP pipes as jackets and HDPE, GRP and steel as core pipes.

IRRIGATION SYSTEMS (LLDPE)

Consists of high precision inline drip pipes and landscape and lawn edging. This range also includes saline resistant valves, drainage systems, sprinklers and central controllers.

REINFORCED THERMOPLASTIC PIPES (RTP)

Available in length of upto 500m, with a working pressure of 150 Bar at a temperature of 60 degrees celsius. RTP is used for gas distribution networks, oil flow lines and water injection lines.

CONTENTS

Fields of Application	2
Features of Cosmoplast Polypropylene System	3
Mechanical & Thermal Properties of PPR	4
Pressure and Temperature	5
Regression Curve of PPR	6
Pipes Specifications	
PN10 Plain PPR Pipes	7
PN20 Plain PPR Pipes	7
PN16 Plain PPR Pipes	7
PN25 PPR / AL / PPR Stabi Pipes	8
PN25 PPR / AL / PE UV Resistant Pipes	8
PN20 PPR / FG / PPR Faser Pipes	9
PN25 PPR FG PPR Faser Pipe	9
PN 20 PPR FG PPR UV Resistant Pipe	9
Longitudinal Expansion	10
Pipe Supports	13
Pressure Loss	14
Pressure Loss Table for Pipes	
PN20 & PN25 at 20°C	15
Composite Polypropylene Pipes	16
Effective Clamping Distances	18
Expansion of PPR Composite Pipes	18
Fusion Welding Process	19
Welding Composite PPR / AL / PPR Stabi and PPR / AL / PE / UV Resistant pipes	20
Electro-fusion Welding Process	21
Handling, Storage and Transportation	22
Transport & Handling	23
Product Range	24
PPR Pipes	25
PPR Fittings	26



COSMOPLAST POLYPROPYLENE PIPES & FITTINGS

With the expertise of manufacturing thermoplastic pipeline systems in the Gulf region for more than four decades Cosmoplast has now developed a complete range of Polypropylene (PP-R) pipes and fittings for cold and hot water distribution systems.

These pipes and fittings are suitable for potable water distribution systems in addition to a wide range of hydro-sanitary applications.

The exceptional heat stability of the polypropylene Random copolymer and its extraction resistance coupled with ease of installation make the PP-R system from Cosmoplast a reliable piping system for hot and cold water applications with a service life in excess of 50 years.

Cosmoplast polypropylene system is made from PP-R granules supplied by the world's renowned resin manufacturers. These granules are pre-coloured and have excellent heat resistance, physical and chemical properties to suit applications such as potable water distribution and heating systems.

Fields of Application:

The Polypropylene system from Cosmoplast can be used for:

- Hot and cold potable water piping networks in residential and commercial buildings. i.e. hospitals, hotels, offices, school buildings etc.
- Chilled water networks in air conditioning systems, as an effective light weight and corrosion free substitute for steel pipes.
- Transport of wide range of chemicals in the industry.
- Irrigation systems for gardens.
- Piping networks for rainwater utilization systems.
- Piping networks for swimming pool facilities.
- Compressed air installations.

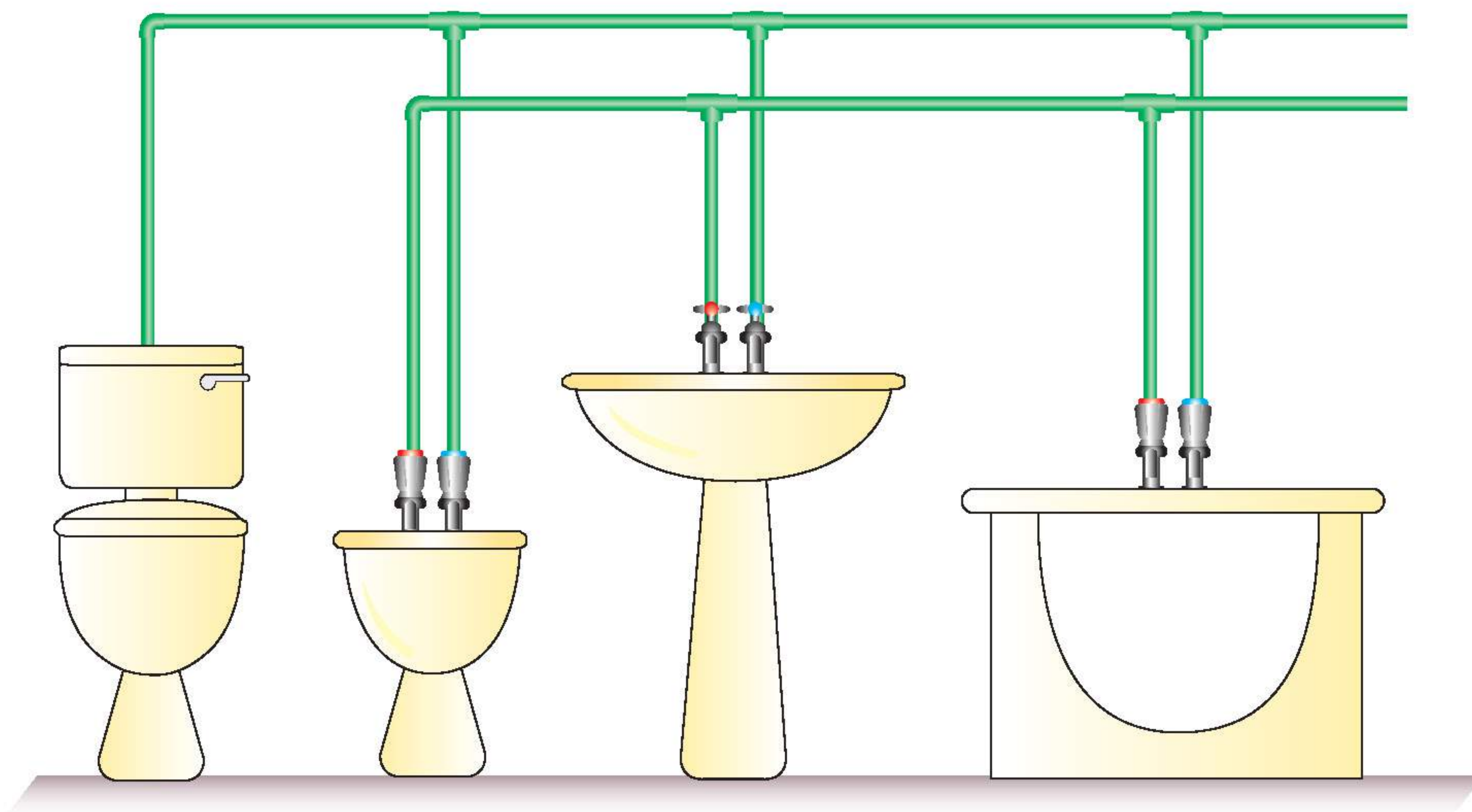

FEATURES OF COSMOPLAST POLYPROPYLENE SYSTEM

- Extended durability due to the high resistance to aggressive elements.
- A Service life in excess of 50 years
- Smooth and porosity-free internal surface of both pipes and fittings thus resulting in a very low pressure loss and absence of incrustation (reduction of section due to the limestone and scaling).
- Non-toxic and physiologically harmless material.
- Resistance to bacterial attack thus enabling safe potable water distribution.
- Resistance to wide range of chemicals, therefore no corrosion in service lines.
- High impact strength.
- Heat preservation and energy -saving abilities. The heat conductivity of PP-R pipes are much lesser than metals and hence offer significantly lower levels of heat loss for transporting fluids.
- High acoustic insulation against fluid noise. The fluid flow and hydraulic shocks within the building create noise which can be avoided by use of the noise absorption ability of PP-R materials.
- Light weight easy to handle material compared to the metallic piping systems (1/9 of the steel specific gravity).
- Convenient and reliable installation methods. The PP-R pipes can even be installed in suspended form under ceiling without problems of deflection.
- Easy interconnection over a complex network.
- No perforation caused by electrical currents.
- Cost effective pipeline network.
- Safe environment as PPR is a recyclable material.

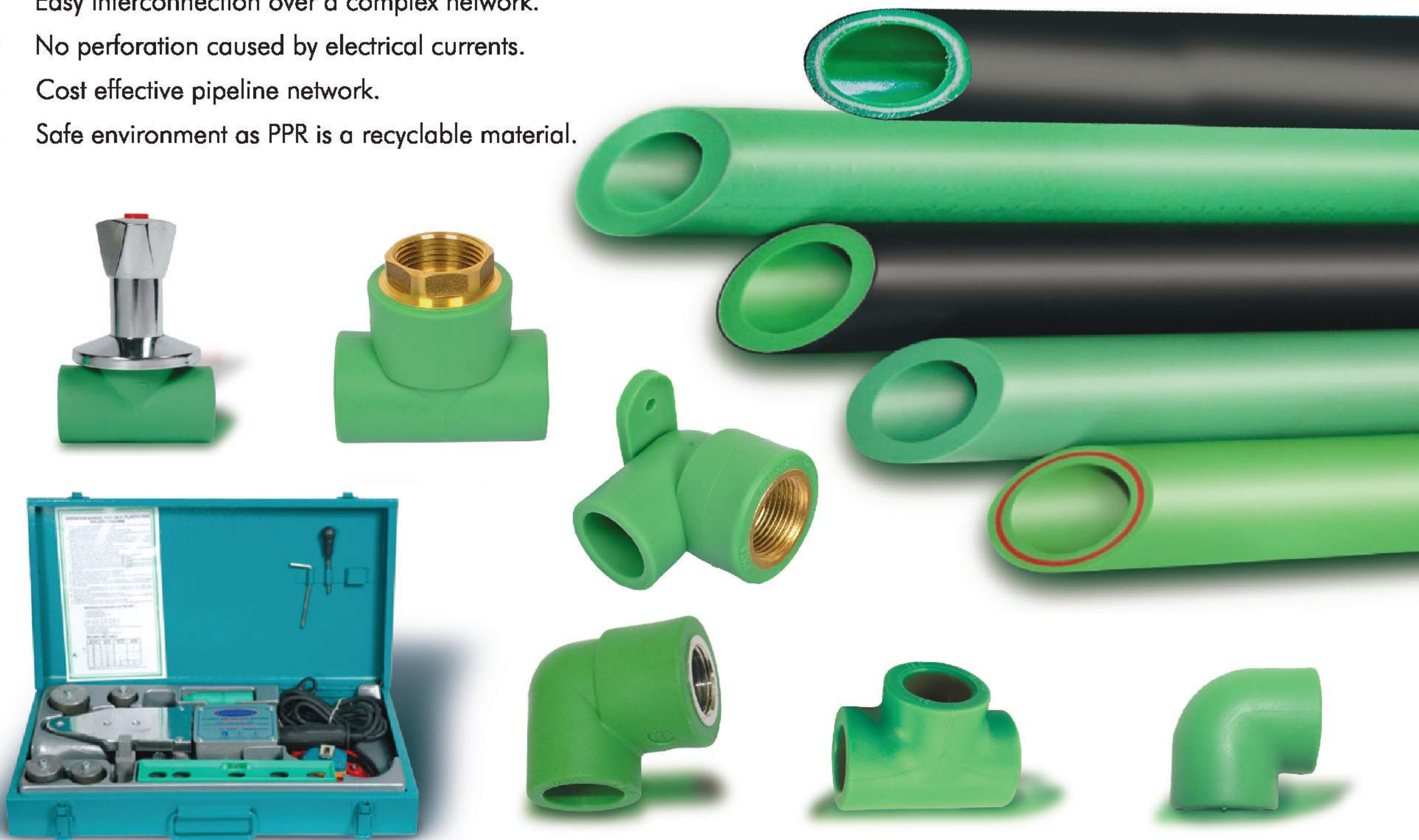

The PP-R system from Cosmoplast - A safe, tough, easy and cost effective solution for hot and cold water applications.



STANDARDS:

Cosmoplast PP-R system is produced according to the following German Standards

DIN 8077	Polypropylene Pipes: Dimensions
DIN 8078	Polypropylene Pipes: Testing Methods
DIN 1988	Drinking water Supply Systems
DIN 16962	Polypropylene Fittings: Quality Controls and Connections
DIN 16928	Thermostatic Pipes: Pipe Connections
DIN 4109	Sound Insulation in Building Constructions
DIN 8076	Metal Threaded Joints Testing Methods
DIN 2999	Rules for Fittings with Threaded Metallic Inserts
DVS 2206	Regulations for the Welding of Thermostatic Material
DVS 207	Welding of Thermoplastic Materials by means of Heating Tools
ISO 15874	Plastics Piping System for Hot and Cold Water Installations

MECHANICAL & THERMAL PROPERTIES OF PPR

PROPERTIES		UNIT	TEST METHOD	VALUE
Density at	+23°C	Kg/m ³	ISO 1183	905
Melt flow Rate	230°C/2.16Kg	g/10min	ISO 1133	0.3
Tensile Stress at Yield	50mm/min	MPa	ISO 527/2	25
Tensile Strain at Yield	50mm/min	%	ISO 527/2	13.5
Tensile Modulus	1mm/min	MPa	ISO 527	800
Flexural Modulus	2mm/min	MPa	ISO 178	850
Shore D Hardness	23°C	***	ISO 868	63.0
Charpy Impact Strength,notched.	23°C	KJ/m ²	ISO 179/1eA	60
Charpy Impact Strength,notched.	0°C	KJ/m ²	ISO 179/1eA	6.0
Charpy Impact Strength,unnotched.	23°C	***	ISO 179/1eU	No break
Charpy Impact Strength,unnotched.	0°C	***	ISO 179/1eU	No break
Vicat Softening Temperature (VST)	10N,50°C/h	°C	ISO2507	128.0
Vicat Softening Temperature (VST)	50N,50°C/h	°C	ISO2507	71.0
Coefficient of thermal expansion	0-110 °C	1/K	DIN 53752	1.83 x 10 ⁻⁴
Thermal conductivity	20°C	W/mK	DIN 52612	0.24

PRESSURE AND TEMPERATURE:

The following table shows the expected life span of Cosmoplast Polypropylene pipes and fittings at various selected pressures and temperatures as per DIN 8077 /8078 Standard.

Temperature (°C)	Operating Years	SDR 11	SDR 7.4	SDR 6/SDR 7.4 Faser Pipe	Faser, PPR/AL & PPR/AL/PE
		PN10	PN16	PN20	PN25
Permissible operational pressure (bar)					
10	1	17.5	27.8	35.1	44.1
	5	16.5	26.2	33.0	41.6
	10	16.1	25.6	32.2	40.5
	25	15.6	24.7	31.1	39.2
	50	15.2	24.1	30.3	38.2
20	1	15.0	23.7	29.9	37.7
	5	14.1	22.3	28.1	35.4
	10	13.7	21.7	27.4	34.5
	25	13.2	21.0	26.4	33.3
	50	12.9	20.4	25.7	32.40
30	1	12.7	20.2	25.4	32.0
	5	11.9	18.9	23.8	30.0
	10	11.6	18.4	23.2	29.2
	25	11.2	17.7	22.3	28.1
	50	10.9	17.2	21.7	27.4
40	1	10.8	17.1	21.6	27.2
	5	10.1	16.0	20.2	25.4
	10	9.8	15.5	19.6	24.7
	25	9.4	15.0	18.8	23.7
	50	9.2	14.5	18.3	23.10
50	1	9.1	14.5	18.2	23.0
	5	8.5	13.5	17.0	21.4
	10	8.2	13.1	16.5	20.8
	25	7.9	12.6	15.9	20.0
	50	7.7	12.2	15.4	19.4
60	1	7.7	12.2	15.4	19.4
	5	7.1	11.3	14.3	18.0
	10	6.9	11.0	13.9	17.5
	25	6.6	10.5	13.3	16.7
	50	6.4	10.2	12.9	16.2
70	1	6.5	10.3	12.9	16.3
	5	6.0	9.5	12.0	15.1
	10	5.8	9.2	11.6	14.6
	25	5.0	8.0	10.0	12.7
	50	4.2	6.7	8.5	10.7
80	1	5.4	8.6	10.8	13.7
	5	4.8	7.6	9.6	12.1
	10	4.0	6.4	8.1	10.2
	25	3.2	5.1	6.5	8.1
95	1	3.8	6.1	7.6	9.6
	5	2.6	4.1	5.2	6.5
	10	2.2	3.4	4.3	5.5



REGRESSION CURVE OF PPR :

DIAGRAM (1)

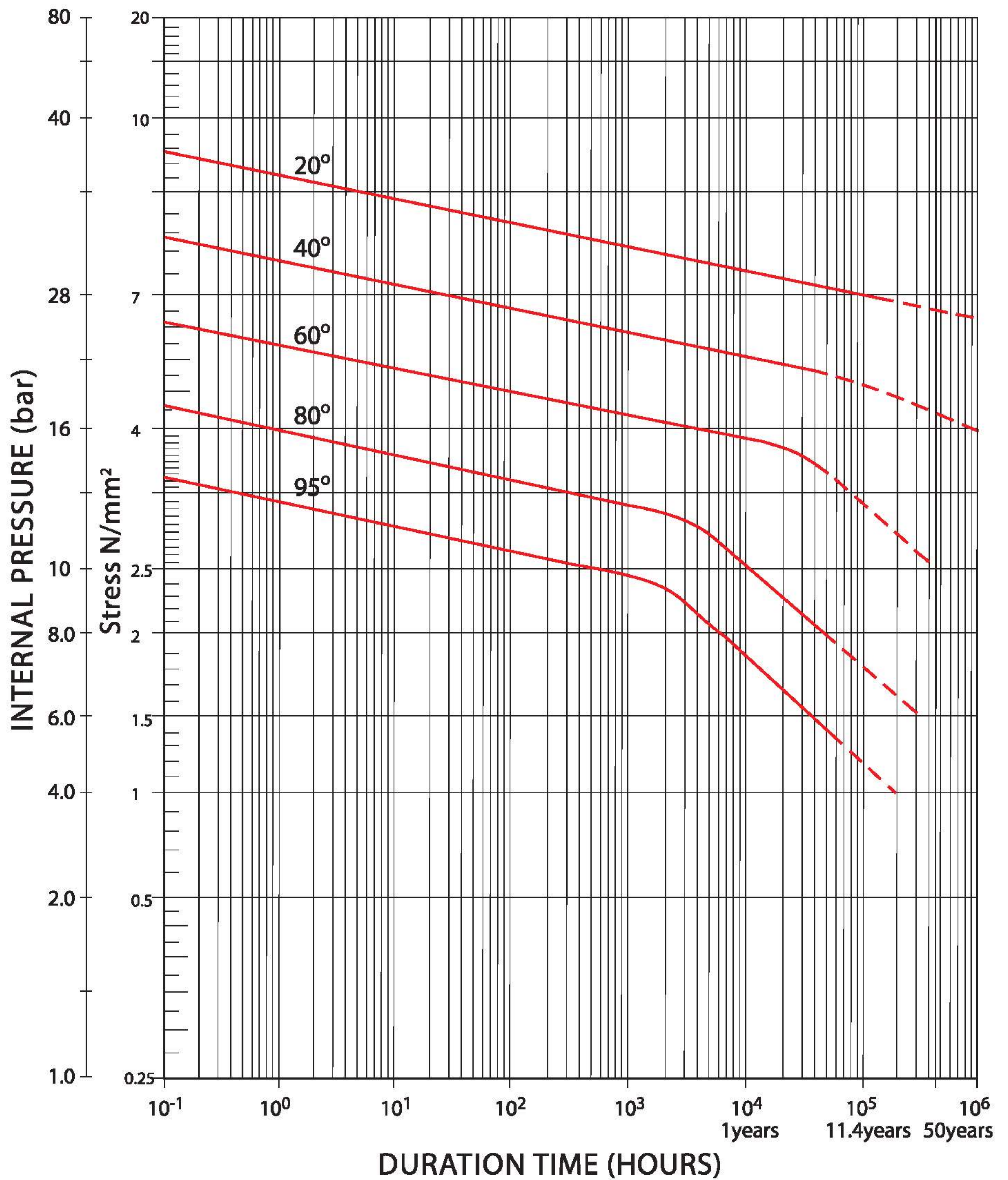

QUALITY CONTROL:

Cosmoplast PP-R systems are produced through a well laid down process consisting of systematic inspections on incoming raw materials, process monitoring, strict testing and final inspections.

Furthermore Cosmoplast is an ISO 9001 certified company with a state of the art QC laboratory to conduct all required tests on the pipes and fittings in order to ensure that they comply with the respective international standards to which they are manufactured.



PIPES SPECIFICATIONS:

Cosmoplast PPR pipes are manufactured according to DIN 8077 and DIN 8078 and they are produced in different pressure ratings and compositions.

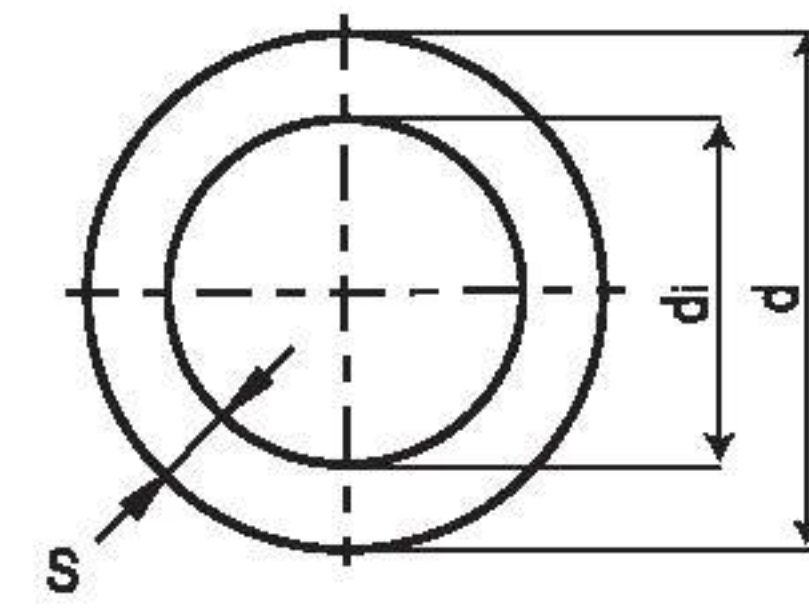

PN10 Plain PPR pipes:

Material : PPR 80
 Pressure Rating : PN10
 SDR : 11
 Standard : DIN8077 / DIN8078 / ISO 15874
 Application : For heating systems, hot and cold water systems. Mainly for domestic applications.



PIPE DATA DIMENSION	* DIAMETER d (mm)	* WALL THICKNESS s (mm)
20 x 1.9	20	1.9
25 x 2.3	25	2.3
32 x 2.9	32	2.9
40 x 3.7	40	3.7
50 x 4.6	50	4.6
63 x 5.8	63	5.8
75 x 6.8	75	6.8
90 x 8.2	90	8.2
110 x 10.0	110	10.0
125 x 11.4	125	11.4
160 x 14.6	160	14.6

* Nominal Size

PN20 Plain PPR pipes:

Material : PPR 80
 Pressure Rating : PN20
 SDR : 6
 Standard : DIN8077 / DIN8078 / ISO 15874
 Application : For heating systems, hot and cold water systems in domestic, commercial and industrial buildings.



PIPE DATA DIMENSION	* DIAMETER d (mm)	* WALL THICKNESS s (mm)
20 x 3.4	20	3.4
25 x 4.2	25	4.2
32 x 5.4	32	5.4
40 x 6.7	40	6.7
50 x 8.3	50	8.3
63 x 10.5	63	10.5
75 x 12.5	75	12.5
90 x 15.0	90	15.0
110 x 18.3	110	18.3
125 x 20.8	125	20.8
160 x 26.6	160	26.6

* Nominal Size

PN16 Plain PPR pipes:

Material : PPR 80
 Pressure Rating : PN16
 SDR : 7.4
 Standard : DIN8077 / DIN8078 / ISO 15874
 Application : For heating systems, hot and cold water systems. Mainly for domestic applications.



PIPE DATA DIMENSION	* DIAMETER d (mm)	* WALL THICKNESS s (mm)
20 x 2.8	20	2.8
25 x 3.5	25	3.5
32 x 4.4	32	4.4
40 x 5.5	40	5.5
50 x 6.9	50	6.9
63 x 8.6	63	8.6
75 x 10.3	75	10.3
90 x 12.3	90	12.3
110 x 15.1	110	15.1
125 x 17.1	125	17.1
160 x 21.9	160	21.9

* Nominal Size



PN25 PPR / AL / PPR Stabi Pipes:

Material : PPR 80 with intergrated aluminum layer.
 Pressure Rating : PN25
 Standard : DIN8077 / DIN8078 / ISO 15874
 Application : sanitary and heating systems in domestic, commercial and industrial buildings.



PN25 PPR / AL / PE UV Resistant Pipes:

Material : PPR 80 with intergrated aluminum layer and external Polyethylene layer.
 Pressure Rating : PN25
 Standard : DIN8077 / DIN8078 / ISO 15874
 Application : for external exposed installations for sanitary and heating systems in domestic, commercial and industrial buildings.



Dimensions of PPR / AL / PPR and PPR / AL /PE Pipes:

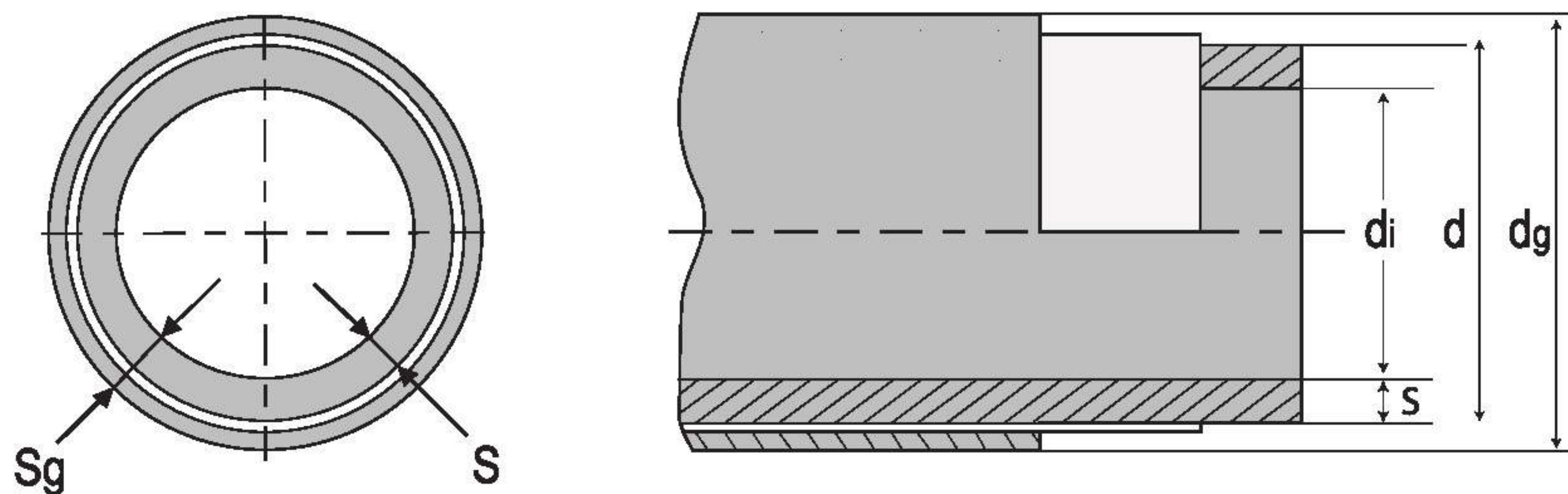

PIPE DATA DIMENSION	*OUTER DIAMETER		* WALL THICKNESS	
	d(mm)	dg (mm)	S (mm)	Sg (mm)
20 x 3.4	20	21.60	3.4	4.10
25 x 4.2	25	26.80	4.2	5.10
32 x 5.4	32	33.80	5.4	6.50
40 x 6.7	40	42.00	6.7	8.10
50 x 8.3	50	52.00	8.3	10.10
63 x 10.5	63	65.00	10.5	12.70
75 x 12.5	75	77.00	12.5	15.10
90 x 15.0	90	97.00	15.0	18.10
110 x 18.3	110	118.00	18.3	22.10

* Nominal Size

* PPR AL PE UV Resistant pipes are available for sizes up to 63mm only.

PN25 PPR / FG / PPR Faser Pipes:

Material : PPR 80 with intergrated fiberglass layer.
 Pressure Rating : PN25
 SDR : 6
 Standard : DIN8077 / DIN8078 / ISO 15874
 Application : sanitary and heating systems in domestic, commercial and industrial buildings.



PIPE DATA	* DIAMETER	* WALL THICKNESS
DIMENSION	d (mm)	s (mm)
20 x 3.4	20	3.4
25 x 4.2	25	4.2
32 x 5.4	32	5.4
40 x 6.7	40	6.7
50 x 8.3	50	8.3
63 x 10.5	63	10.5
75 x 12.5	75	12.5
90 x 15.0	90	15.0
110 x 18.3	110	18.3
125 x 20.8	125	20.8
160 x 26.6	160	26.6

* Nominal Size

PN20 PPR / FG / PPR Faser Pipes and PN 20 PPR/FG/PPR UV Resistant Pipes (For Exposed Installation)

Material : PPR 80 with intergrated fiberglass layer.
 Pressure Rating : PN20
 SDR : 7.4
 Standard : DIN8077 / DIN8078 / ISO 15874
 Application : sanitary and heating systems in domestic, commercial and industrial buildings.



PIPE DATA	* DIAMETER	* WALL THICKNESS
DIMENSION	d (mm)	s (mm)
20 x 2.8	20	2.8
25 x 3.5	25	3.5
32 x 4.4	32	4.4
40 x 5.5	40	5.5
50 x 6.9	50	6.9
63 x 8.6	63	8.6
75 x 10.3	75	10.3
90 x 12.3	90	12.3
110 x 15.1	110	15.1
125 x 17.1	125	17.1
160 x 21.9	160	21.9

* Nominal Size

* PN 20 PPR FG PPR UV Resistant Pipes are available for sizes up to 110mm only



LONGITUDINAL EXPANSION:

The following schemes demonstrate some important cases:

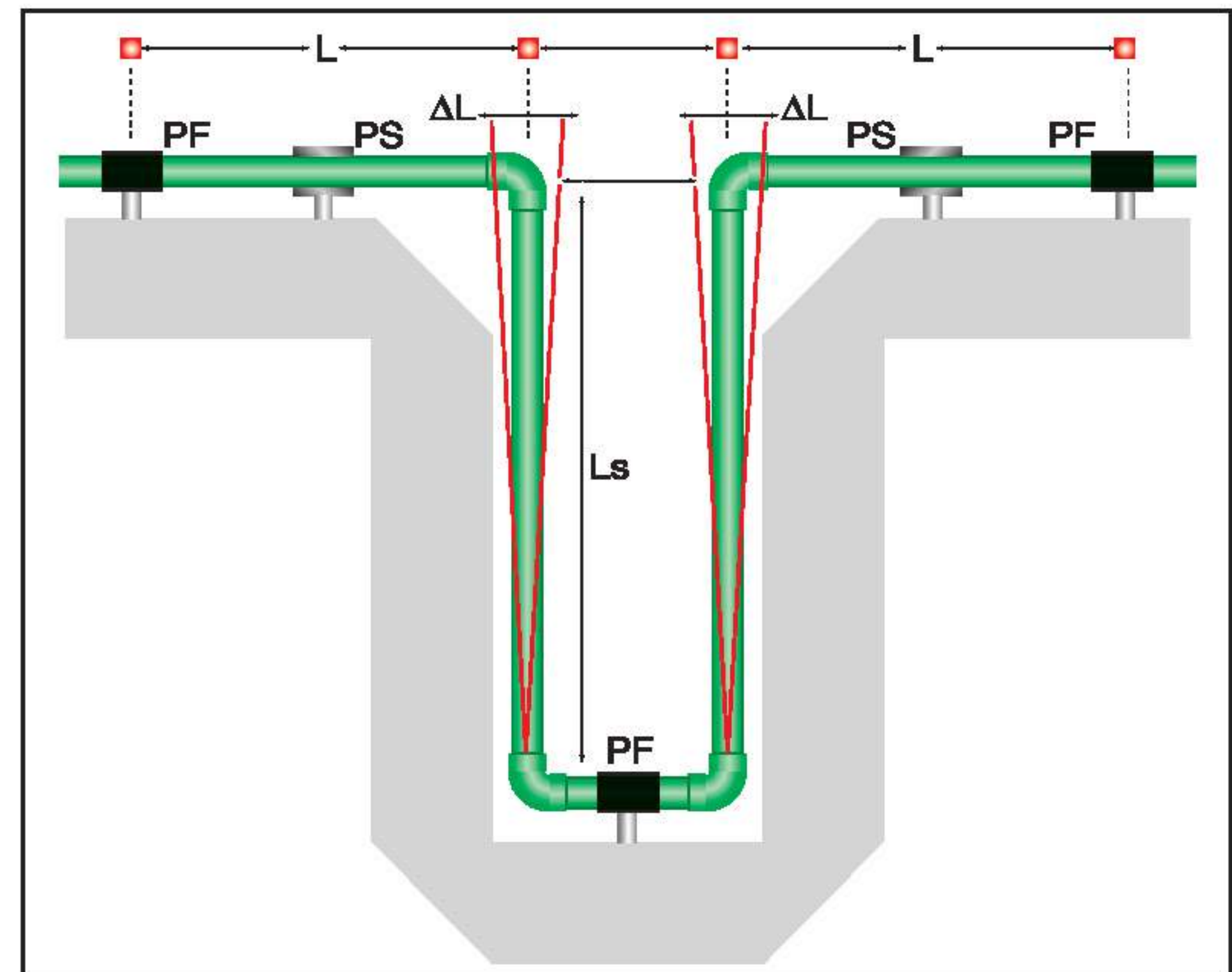
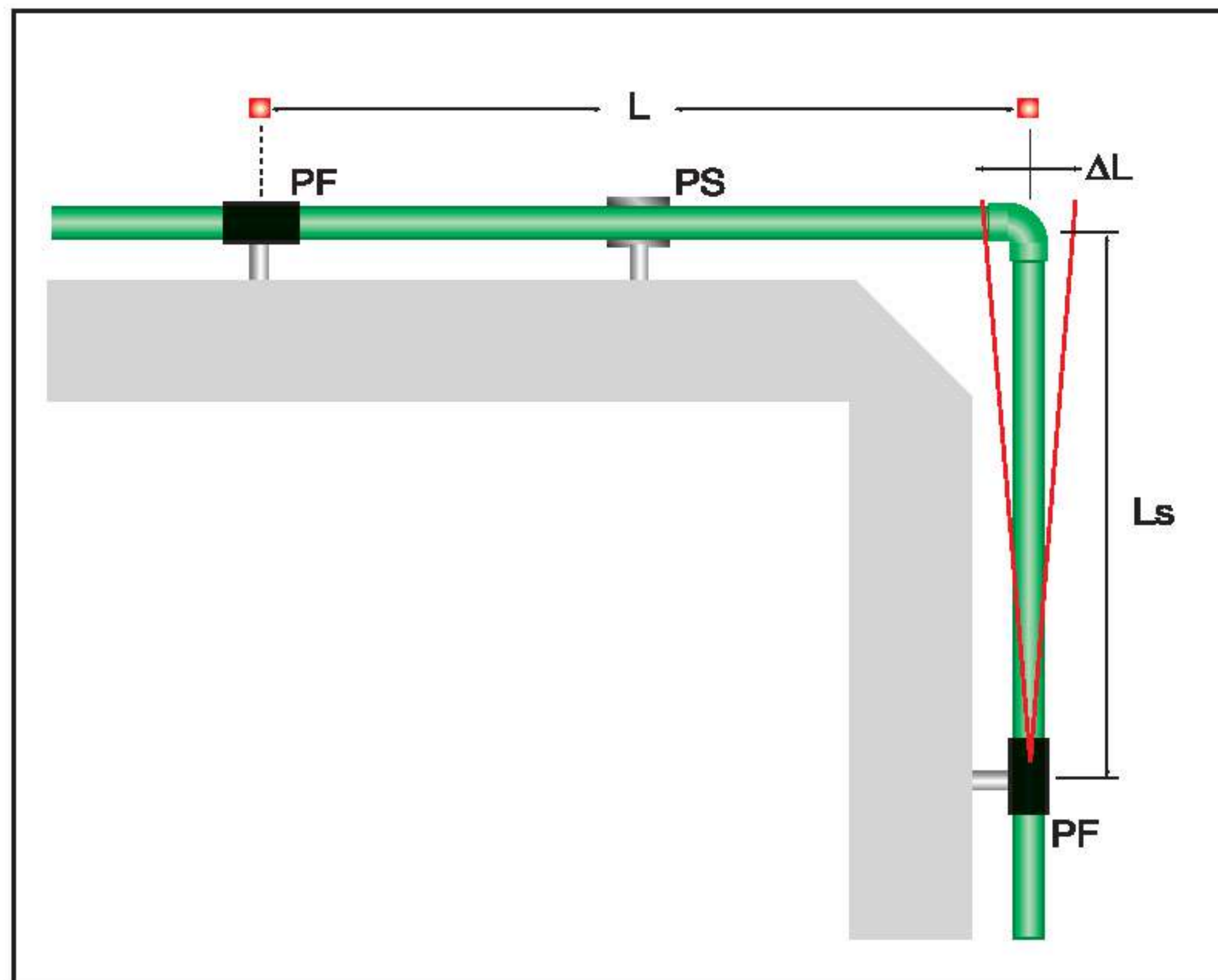

PF= Fixed Point; PS= Sliding Point

A. Exposed Installations:

Longitudinal expansion depends on the temperature variation the pipes are exposed to. If the working temperature of the system undergoes variations up to 10 -15°C the pipe elongation should be evaluated and considered. Cold water pipes have low linear expansion and hence can be neglected. But in case of hot water and heating installations, the longitudinal expansion must be considered and the installations must be planned and performed accordingly.

Thermal expansion of Polypropylene pipes can be evaluated using the following formula:

$$\Delta L = \alpha \times L \times \Delta t$$

Where:

ΔL = Linear expansion in mm.

α = Coefficient of linear expansion = 0.18mm/mK

L = Initial pipe length in m.

Δt = The difference between the temperature at which the system is installed and the operating temperature.

Compensation of Longitudinal Expansion:

For exposed installations, the length variation due to longitudinal expansion should be compensated by a calculated and planned change of direction.

The free pipe length "Ls" is the length of pipe that should be kept free without clamping so as to compensate for the expansion. It is calculated with the following formula:

$$L_s = K \times \sqrt{d \times \Delta L}$$

Where:

- Ls = Free pipe length in mm
- ΔL = Linear expansion in mm
- d = External diameter of pipe in mm.
- K = 20 Constant for the PP-R material.

Example:

If a pipe of 25mm diameter with 4m length, undergoes a potential temperature variation of 50° C. The thermal expansion calculations result the following:

The variation in length:

$$\Delta L = \alpha \times L \times \Delta t = 0.18 \times 4 \times 50 = 36\text{mm}$$

The free pipe length:

$$L_s = K \times \sqrt{d \times \Delta L} = 20 \times \sqrt{25 \times 36} = 600\text{mm}$$

The longitudinal expansion of plain PPR pipes can be taken directly from the below table

Pipe length in metres l (m)	Longitudinal Expansion (mm): PPR Plain Pipes							
	Temperature difference Δt (°C)							
	10	20	30	40	50	60	70	80
0.1	0.18	0.36	0.54	0.72	0.9	1.08	1.26	1.44
0.2	0.36	0.72	1.08	1.44	1.8	2.16	2.52	2.88
0.3	0.54	1.08	1.62	2.16	2.7	3.24	3.78	4.32
0.4	0.72	1.44	2.16	2.88	3.6	4.32	5.04	5.76
0.5	0.9	1.8	2.7	3.6	4.5	5.4	6.3	7.2
0.6	1.08	2.16	3.24	4.32	5.4	6.48	7.56	8.64
0.7	1.26	2.52	3.78	5.04	6.3	7.56	8.82	10.08
0.8	1.44	2.88	4.32	5.76	7.2	8.64	10.08	11.52
0.9	1.62	3.24	4.86	6.48	8.1	9.72	11.34	12.96
1.0	1.8	3.6	5.4	7.2	9	10.8	12.6	14.4
2.0	3.6	7.2	10.8	14.4	18	21.6	25.2	28.8
3.0	5.4	10.8	16.2	21.6	27	32.4	37.8	43.2
4.0	7.2	14.4	21.6	28.8	36	43.2	50.4	57.6
5.0	9	18	27	36	45	54	63	72
6.0	10.8	21.6	32.4	43.2	54	64.8	75.6	86.4
7.0	12.6	25.2	37.8	50.4	63	75.6	88.2	100.8
8.0	14.4	28.8	43.2	57.6	72	86.4	100.8	115.2
9.0	16.2	32.4	48.6	64.8	81	97.2	113.4	129.6
10.0	18	36	54	72	90	108	126	144



The longitudinal expansion and free pipe length can be taken from the below diagram

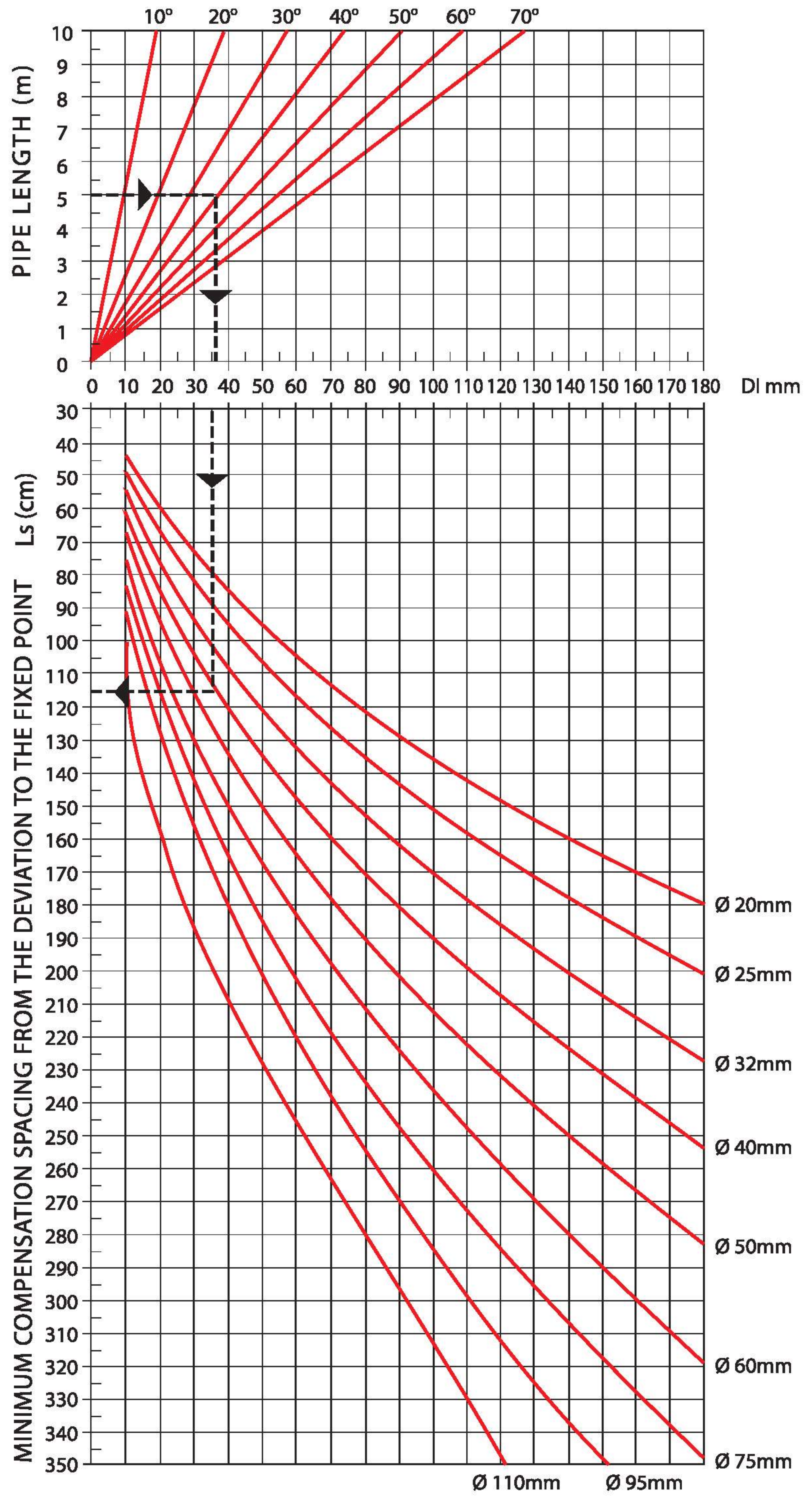

DIAGRAM (2)

B. Concealed Installation

Concealed installations generally do not require any special consideration for linear expansion as there is enough room to accommodate the expansion of the pipe as per the guidelines of installation according to DIN 1988. Where there is no room to accommodate such expansion, the material absorbs all the stress arising from residual expansion.

PIPE SUPPORTS:

When pipe clamping techniques are considered, two types of clamping joints must be identified; fixed points and sliding points. Fixed clamps hold the pipes in a rigid manner, while a sliding point allows the pipe to move in the axial direction of the pipe.

Fixed points divide the pipe network into individual sections. Given this, the possible longitudinal expansion and the corresponding free length from the fixed pipe points must be calculated.

Sliding points should be located so that the axial movement of longitudinal expansion is not influenced by the fixed connection points. Given this, the sliding Points should not be installed on either side of the fittings in order to avoid acting as fixed points.

It is important, that the clamp or fastening material does not damage the surface of the pipe. The ideal fastening material for PP-R pipes are rubber lined clamps which ensure that no mechanical damage of the pipe surface can occur.

The following table shows the effective spans between clamps for horizontal lines at selected temperature differences:



PIPE DIA. (mm)	CLAMPING DISTANCE (cm)						
	Temperature Difference (°C)						
	0	20	30	40	50	60	70
20	90	65	65	60	60	55	50
25	110	80	75	70	70	65	60
32	120	95	95	85	80	75	70
40	145	110	100	90	90	85	80
50	170	130	120	110	110	100	95
63	190	150	140	130	120	110	100
75	210	160	150	140	130	120	110
90	220	160	160	150	150	140	125
110	250	180	180	170	170	160	140



PRESSURE LOSS:

The characteristics of PPR material enable to obtain at the extrusion phase very smooth walls (roughness = 0.0070) which reduces the friction losses and improves the performance of the whole system. These factors allow using higher water speed in the circuits without having negative effects in the system as the case in other piping systems.

The maximum allowed speed for cold water is 5 m/s, while for hot water (higher than 70°C), it is advisable not to exceed 3 m/s. The pressure losses in PPR can be taken directly from following diagrams:

Pressure Loss Diagrams:

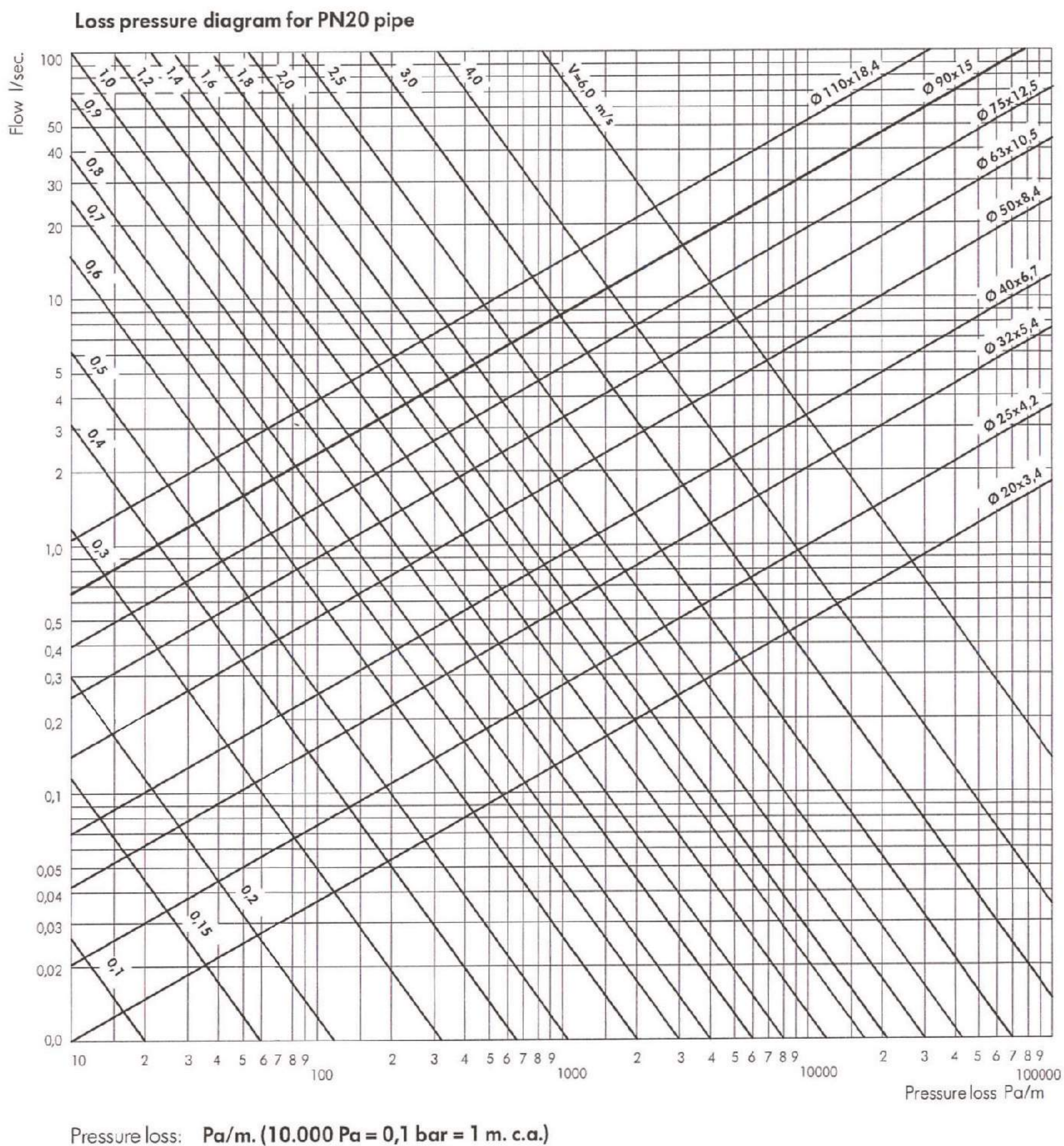

Pressure Loss Table for Pipes:

PN 20 & PN 25 at 20°C

q	DN	20x3,4	25x4,2	32x5,4	40x6,7	50x8,4	63x10,5	75x12,5	90x15,0
0,01	R	0,09	0,02	0,01	0,00	0,00	0,00	0,00	0,00
	v	0,07	0,05	0,03	0,02	0,01	0,01	0,01	0,00
0,02	R	0,29	0,10	0,03	0,01	0,00	0,00	0,00	0,00
	v	0,15	0,09	0,06	0,04	0,02	0,01	0,01	0,01
0,03	R	0,60	0,20	0,06	0,02	0,01	0,00	0,00	0,00
	v	0,22	0,14	0,08	0,05	0,03	0,02	0,02	0,01
0,04	R	0,99	0,33	0,10	0,04	0,01	0,00	0,00	0,00
	v	0,29	0,18	0,11	0,07	0,05	0,03	0,02	0,01
0,05	R	1,46	0,49	0,15	0,05	0,02	0,01	0,00	0,00
	v	0,37	0,23	0,14	0,09	0,06	0,04	0,03	0,02
0,06	R	2,02	0,67	0,21	0,07	0,02	0,01	0,00	0,00
	v	0,44	0,28	0,17	0,11	0,07	0,04	0,03	0,02
0,07	R	2,65	0,88	0,27	0,09	0,03	0,01	0,00	0,00
	v	0,51	0,32	0,20	0,13	0,08	0,05	0,04	0,02
0,08	R	3,36	1,12	0,35	0,12	0,04	0,01	0,01	0,00
	v	0,58	0,37	0,23	0,14	0,09	0,06	0,04	0,03
0,09	R	4,15	1,38	0,43	0,14	0,05	0,02	0,01	0,00
	v	0,66	0,42	0,25	0,16	0,10	0,06	0,05	0,03
0,10	R	5,02	1,66	0,51	0,17	0,06	0,02	0,01	0,00
	v	0,73	0,46	0,28	0,18	0,12	0,07	0,05	0,04
0,12	R	6,97	2,30	0,71	0,24	0,08	0,03	0,01	0,00
	v	0,88	0,55	0,34	0,22	0,14	0,09	0,06	0,04
0,14	R	9,22	3,03	0,93	0,31	0,11	0,04	0,02	0,01
	v	1,02	0,65	0,40	0,25	0,16	0,10	0,07	0,05
0,16	R	11,76	3,85	1,18	0,40	0,14	0,04	0,02	0,01
	v	1,17	0,74	0,45	0,29	0,18	0,12	0,08	0,06
0,18	R	14,58	4,77	1,46	0,49	0,17	0,06	0,02	0,01
	v	1,32	0,83	0,51	0,32	0,21	0,13	0,09	0,06
0,20	R	17,68	5,77	1,76	0,59	0,20	0,07	0,03	0,01
	v	1,46	0,92	0,57	0,36	0,23	0,14	0,10	0,07
0,30	R	37,38	12,09	3,66	1,22	0,42	0,14	0,06	0,02
	v	2,19	1,39	0,85	0,54	0,35	0,22	0,15	0,11
0,40	R	63,95	20,54	6,18	2,05	0,70	0,23	0,10	0,04
	v	2,92	1,85	1,13	0,72	0,46	0,29	0,20	0,14
0,50	R	97,60	31,08	9,31	3,07	1,05	0,34	0,15	0,06
	v	3,65	2,31	1,42	0,90	0,58	0,36	0,25	0,18
0,60	R	137,4	43,69	13,03	4,28	1,46	0,47	0,20	0,08
	v	4,38	2,77	1,70	1,08	0,69	0,43	0,31	0,21

q - Flow rate (L/S), R - Pressure losses (mbar/m), v - Flow speed (m/s)

*Pressure loss table for fittings can be provided as per customer request.



COSMOPLAST COMPOSITE POLYPROPYLENE PIPES:

The technology of Composite PPR pipes has been developed due to the increasing need for PPR pipes that can be used in applications where the normal plain PPR pipes can not be implemented. This composite technology could offer easy solutions to the expansion of PPR pipes and to the UV exposure in case of external installations.

(A) Cosmoplast PPR / AL / PPR Stabi Pipes

The Polypropylene piping industry has been witnessing major innovations in recent times and in order to cater to the need for these innovative products, Cosmoplast has extended its polypropylene product range with the addition of a new Polypropylene (PP-R) / Aluminium (Al) composite pipe. This new pipe system comprises of an aluminum layer, integrated within the polypropylene pipe structure. This innovative product is thus made of a unique combination of materials with each adding their own benefits to the final product.



Cosmoplast PP-R/ Aluminium/ PP-R composite pipes for hot and cold water distribution systems are suitable for high pressure potable water distribution systems in addition to a wide range of other hydro-sanitary applications and will provide an operational service life in excess of over 50 years.

The exceptional reduction in thermal expansion of the PP-R/Al / PPR composite pipes makes this product an extremely reliable and stable product for use in hot and cold water applications.

Cosmoplast PPR/AL/PPR Stabi pipes are manufactured according to the standards DIN8077 and DIN8078 , PN25

Fields Of Applications:

Cosmoplast composite PPR/AL/PPR pipes are used for:

- Hot and cold potable water networks in residential, industrial and commercial buildings. i.e. hospitals, hotels, schools, offices, factories etc.
- Chilled water networks in Air Conditioning systems providing an effective light weight and corrosion free substitute for steel pipes.
- Transportation of wide range of chemicals within industrial processes.
- Piping networks for swimming pools facilities.
- Compressed air installations.

(B) Cosmoplast PPR / AL / PE Pipes, UV Resistant for External Installations

PPR pipes are often used for external exposed installations, in which case the pipework has to be insulated to avoid direct exposure to UV light which may damage the pipes. Cosmoplast PPR/AL/PE UV Resistant composite pipes are the easy solution for external installations due to the innovative combination between PPR, Aluminium and Polyethylene.

This technology is very similar to the Stabi PPR/AL/PPR technology, however the external layer is made of polyethylene instead of PPR. This external PE layer provides the necessary protection to the PPR pipe due to



its superior characteristics that enables it to resist direct exposure to sunlight (UV).

Cosmoplast PPR/AL/PE UV Resistant pipes provide the same outstanding performance as PPR/AL/PPR Stabi pipes in terms of reducing the thermal expansion, thanks to the aluminium layer integrated in the structure of this pipe. Therefore PPR/AL/PE UV Resistant Pipes can be used for the same applications as the PPR/AL/PPR Stabi pipes in addition to the exposed external installations.

Cosmoplast PPR/ AL/PE UV Resistant Pipes are manufactured according to the standards DIN8077 and DIN8078 , PN25

(C) Cosmoplast PPR / FG / PPR Faser Pipes



Cosmoplast PPR/FG/PPR Faser pipes are composite pipe consist of an integrated middle layer of special formulated fibreglass (FG) impeded between an internal and external PPR layers.

The presence of fibreglass layer increases the strength of the pipe in such a way that the pipe can be produced as SDR 7.4 but with pressure rating of PN20 instead of PN16, which means bigger ID and higher flow compared to SDR 6 PN20 pipes. The expansion of these pipes is also reduced to a almost the same expansion of PPR Stabi pipes.

Cosmoplast PPR/FG/PPR Faser pipes are manufactured according to the standards DIN8077 and DIN8078 , PN20, SDR 7.4. and SDR 6 PN 25

COMPOSITE-TECHNOLOGY:

With the PPR/AL/PPR/Stabi, PPR/FG/PPR Faser Pipes and PPR/AL/PE/UV Resistant Pipes, the linear thermal expansion is reduces by at least 75% when compared to standard PP-R Pipes and hence has the following characteristics.

- The coefficient of linear expansion is almost identical to that of metal pipes.
- In comparison with other plastic pipe systems the supporting clamp intervals can be increased leading to a reduction in the number of mounting clips being used.
- Optimum cost-performance ratio in comparison to metal pipes.
- Lower weight than equivalent metal pipes.
- High impact strength.



EFFECTIVE CLAMPING DISTANCES:

Effective clamping distance for Composite PPR/AL/PPR Stabi Pipe, PPR/FG/PPR Faser Pipe and PPR/AL/PE UV resistant pipes.

PIPE DIA. (mm)	CLAMPING DISTANCE (m)						
	Temperature Difference (°C)						
	0°C	20°C	30°C	40°C	50°C	60°C	70°C
20	1.5	1.15	1.15	1.05	1.05	0.95	0.95
25	1.65	1.25	1.25	1.15	1.15	1.1	1.05
32	1.9	1.5	1.45	1.4	1.35	1.3	1.25
40	2.15	1.7	1.7	1.65	1.6	1.55	1.45
50	2.4	1.9	1.85	1.8	1.75	1.7	1.65
63	2.65	2.15	2.1	2.05	2	1.85	1.8
75	2.8	2.2	2.15	2.1	2.1	2	1.95
90	3	2.3	2.3	2.2	2.2	2.1	2
110	3.25	2.5	2.4	2.3	2.1	2	2

EXPANSION OF PPR COMPOSITE PIPES:

The expansion of composite PPR/AL/PPR Stabi Pipe, PPR/FG/PPR Faser Pipe and PPR/AL/PE UV resistant pipes are 75% less than the normal PPR pipes. as noted in the below table.

Pipe length in metres l (m)	Longitudinal Expansion: PPR Composite Pipes							
	Temperature difference Δt (°C)							
	10	20	30	40	50	60	70	80
0,1	0,03	0,06	0,09	0,12	0,15	0,18	0,21	0,24
0,2	0,06	0,12	0,18	0,24	0,30	0,36	0,42	0,48
0,3	0,09	0,18	0,27	0,36	0,45	0,54	0,63	0,72
0,4	0,12	0,24	0,36	0,48	0,60	0,72	0,84	0,96
0,5	0,15	0,30	0,45	0,60	0,75	0,90	1,05	1,20
0,6	0,18	0,36	0,54	0,72	0,90	1,08	1,28	1,44
0,7	0,21	0,42	0,63	0,84	1,05	1,26	1,47	1,68
0,8	0,24	0,48	0,72	0,96	1,20	1,44	1,68	1,92
0,9	0,27	0,54	0,81	1,08	1,35	1,62	1,89	2,16
1,0	0,30	0,60	0,90	1,20	1,50	1,80	2,10	2,40
2,0	0,60	1,20	1,80	2,40	3,00	3,60	4,20	4,80
3,0	0,90	1,80	2,70	3,60	4,50	5,40	6,30	7,20
4,0	1,20	2,40	3,60	4,80	6,00	7,20	8,40	9,60
5,0	1,50	3,00	4,50	6,00	7,50	9,00	10,50	12,00
6,0	1,80	3,60	5,40	7,20	9,00	10,80	12,80	14,40
7,0	2,10	4,20	6,30	8,40	10,50	12,60	14,70	16,80
8,0	2,40	4,80	7,20	9,60	12,00	14,40	16,80	19,20
9,0	2,70	5,40	8,10	10,80	13,50	16,20	18,90	21,60
10,0	3,00	6,00	9,00	12,00	15,00	18,00	21,00	24,00

FUSION WELDING PROCESS

Cosmoplast PPR pipes and fittings are jointed using heating process called fusion welding. The process is very simple and results in inseparable water tight joints. It is carried out using an electric fusion welding machine that simultaneously heats the internal surface of the fitting and the external surface of the pipe which are then joined together to form inseparable water tight joints.

The following sections demonstrate the basic procedure for fusion welding process for plain and composite PPR pipes.

Welding Plain and PPR / FG / PPR Faser pipes:

The following steps describe the steps of the welding process:

1. Prepare the welding machine by fitting it with the welding dies of the diameters to be welded. Connect the plug to the 220 V power supply socket and wait until the machine reaches the working temperature (260°C).
2. Cut the pipe at right angles to the pipe axis using suitable pipe cutter.
3. Remove any burrs or cutting chips by deburring the cutting area.
4. Mark the welding depth on the pipe using a suitable marker.
5. Without turning insert the end of the pipe into the heating sleeve up to the marked welding depth and at the same time slide without turning the fitting into the other side of the heating tool up to the stop.
6. Leave the pipe and fitting on the heating tool until the heating time is elapsed.
7. At the end of the heating time, remove the pipe and fitting from the heating tool and push them immediately into each other up to the mark indicating the welding depth. At this stage the depth mark will be covered by the welding bead. During this process, do not rotate the pipe and fitting relative to each other.
8. Allow the joint to cool fully before using.





Welding Composite PPR / Al / PPR Stabi and PPR / Al / PE UV Resistant pipes:

The welding process of composite pipes is identical to that for plain PPR pipes. However, the external and intermediate layers should first be shaved off before proceeding in the fusion process.

The following steps describe the steps of the welding process:

1. Prepare the welding machine by fitting it with the welding dies of the diameters to be welded. Connect the plug to the 220 V power supply socket and wait until the machine reaches the working temperature (260°C).
2. Cut the pipe at right angles to the pipe axis using suitable pipe cutter.
3. Remove any burrs or cutting chips by deburring the cutting area.
4. Use the pipe shaving tool to peel off the outer layer (PPR in case of Stabi pipes or PE in case of UV resistant pipes) and the intermediate aluminum layer. This can be done by fully pushing the end of the composite pipe inside the shaving tool until it reaches the stops inside the shaver. It is not necessary to mark the welding depth as the stop inside the shaving tool sets the correct welding depth.
5. Without turning insert the end of the pipe into the heating sleeve up to the marked welding depth and at the same time slide without turning the fitting into the other side of the heating tool up to the stop.
6. Leave the pipe and fitting on the heating tool until the heating time is elapsed.
7. At the end of the heating time, remove the pipe and fitting from the heating tool and push them immediately into each other up to the mark indicating the welding depth. At this stage the depth mark will be covered by the welding bead. During this process, do not rotate the pipe and fitting relative to each other.
8. Allow the joint to cool fully before using.

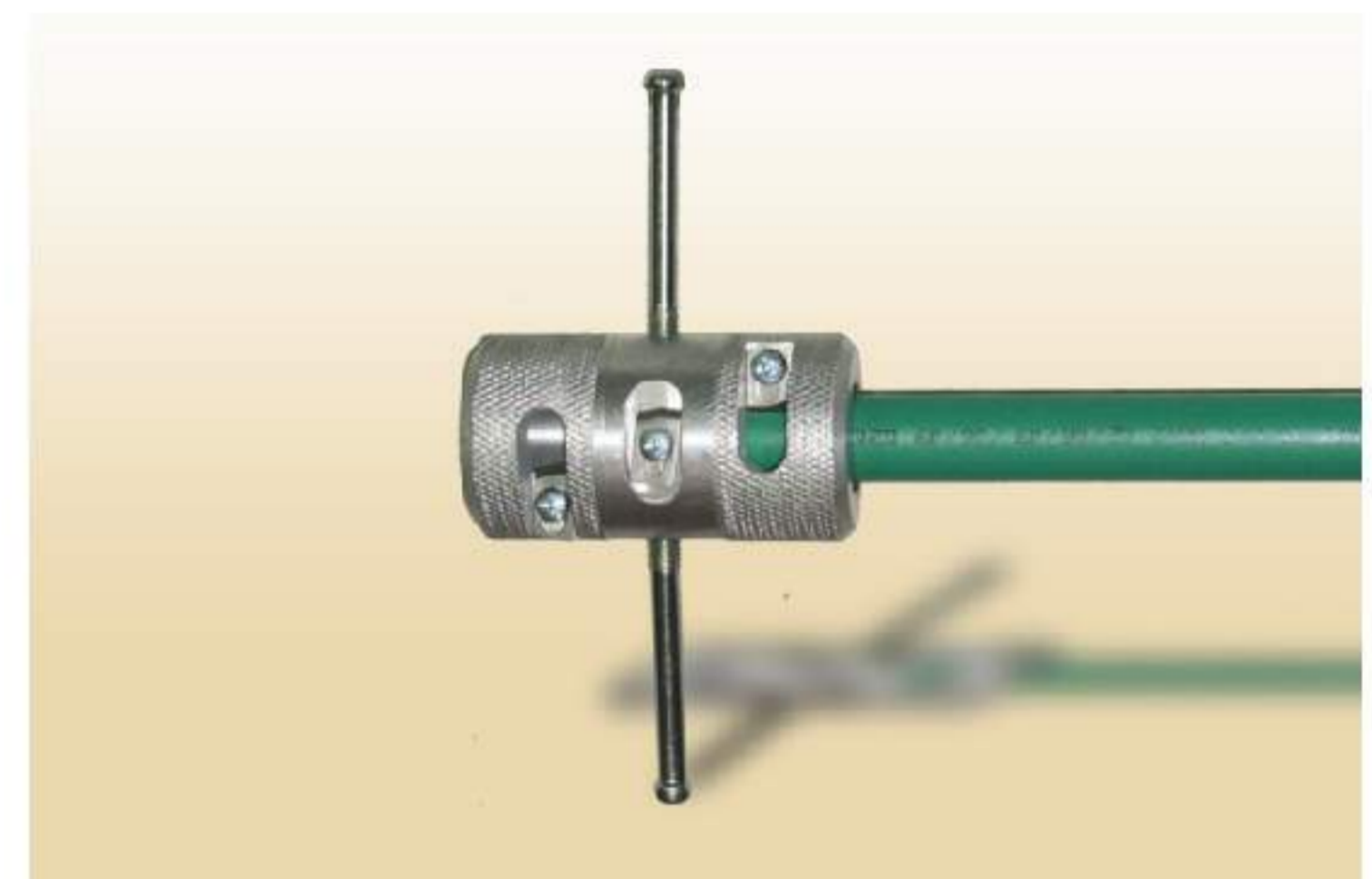

Pipe Dia (mm)	Heating time (secs)	Processing Time (secs)	Cooling Time (mins)
20	5	4	2
25	7	4	2
32	8	6	4
40	12	6	4
50	18	6	4
63	24	8	6
75	30	8	8
90	40	8	8
110	50	10	8
125	60	10	8
160	100	10	10

Electro-fusion Welding Process

The electro-fusion welding process is used for emergency repairs or when welding has to be done in small places or in positions not assessable by the polyfusion welding machine.

Electro-Fusion process is carried out using special welding machine and PPR Electro-Fusion sockets. The Electro-fusion sockets are provided with 2 socket ends that can be welded in a single operation.

The Electro-Fusion sockets include built in resistance coil in their body, the welding machine sends current through the resistance coil that cause the PPR material to melt and therefore the two sides of the socket and the pipes are fused together at the same time.

The electro-fusion sockets have stops on their internal surface up to which the pipe should be inserted inside the socket. These stops can be removed with sharp blade in case the electro-Fusion sockets are to be used as sliding couplers.

The electro-fusion sockets have two pins on the external surface, to which the welding machine is connected while performing the welding process. The two indicators will appear during the welding process to indicate that the welding temperature has been reached.

After performing the electro-fusion process, the internal surface of the socket and the external surface of the pipe will be fused together.

Quality electro-fusion joints are guaranteed only if the socket and pipe surfaces are free from moisture, dirt and grease.

The electro-fusion process is done as detailed below:

1. Cut the pipe at right angles to the pipe axis using suitable pipe cutter.
2. Clean the parts of the pipe to be welded and the fitting in order to avoid any dust or sand that might damage the quality of the joint.
3. Remove the welding electrofusion sockets from their protective packing and immediately fit the pipes ends in the welding socket; the correct depth of connection is when the pipe touches the stops.
4. Hold the pipes in their position during the welding process.
5. Connect the welding machine to the welding socket and start the welding machine. The springing out of the two indicator pins indicates that the heating time has ended.
6. Disconnect the welding machine from the welding socket.
7. When welding is completed, it is recommended not to apply any mechanical stress (by deflections, torsions, tractions) to the joint for at least 20 minutes.



Note: Electro Fusion process is applicable for pipe to pipe connection only.



HANDLING, STORAGE AND TRANSPORTATION

PPR pipes and fittings should be handled with care considering the resilience of these pipes and fittings. Transportation, storage and handling should be done taking into consideration the below directions and precautions.

Handling

- Take all reasonable care when handling PPR, particularly in very cold conditions when the impact strength of the material is reduced.
- Do not throw or drop pipes, or drag them along hard surfaces.
- Do not scratch pipes against hard surfaces or drag them along the ground.
- In case of mechanical handling, use protective slings and padded supports. Metal chains and hooks should not make direct contact with the pipe.

Storage

- PPR Pipes & fittings should be stored in covered areas away from direct sun light.
- To avoid deformation over time, pipes should be stacked on a flat base or on a level ground with maximum stack height of 1.5m.
- Provide side support at 1m centers.
- Store all materials in well-ventilated, shady conditions in covered stores.
- Avoid direct exposure to sunlight for long periods.
- keep pipes in their nylon packing and fittings in their original packaging until required for use
- Ideally, stacks should contain one diameter pipe size only. Where this is not possible, stack largest diameter pipes at base of stack.
- Do not place heavy items on top of the pipes.
- Pipes should be kept clean as much as possible, as this may save cleaning time while preparing pipes for welding.
- While stores at site or during temporary storage outdoor, PPR Pipes and fittings should be covered with proper sheet for protection from UV.



Transport

- While transport, pipes should be arranged safely on trucks avoiding crossing, bending and over stacking.
- The pipes should also be fully supported over their total length.
- Proper protection should be provided if chains or cords are used to tie down the load in order to avoid damaging the pipes.



SUGGESTIONS FOR THE CORRECT HANDLING OF PP-R SYSTEM:

- Handle Pipes with care, and avoid hard impacts at the end of the pipes.
- Use suitable sharp cutting tools to cut the pipe with no burrs.
- Do not twist the pipe or the fitting after joining together. Alignment up to 5 degrees relative to the axis of the pipe can be done immediately after joining.
- Protect the pipes from sunlight and rain during storage and on site.
- Do not use a flame to bend the pipes; heating with hot air up to 140°C can be used when needed.
- Use Teflon sealing tapes where necessary.
- Avoid heavy and sharp loads on the pipes.
- Follow the instructions for joining process.
- Follow the right techniques for expansion compensation.
- Always protect the pipes from direct exposure to sunlight by proper insulation or painting.
- When connecting two threaded fittings, use reasonable quantity of teflon sealing tape and avoid using excess quantity.



PRODUCT RANGE



Cosmoplast PPR pipes to DIN 8077/DIN 8078 / ISO 15874 and fittings to DIN 16962 / ISO 15874 PN 25

PRODUCT RANGE

PPR PIPES

PN 10 - PLAIN PPR PIPES

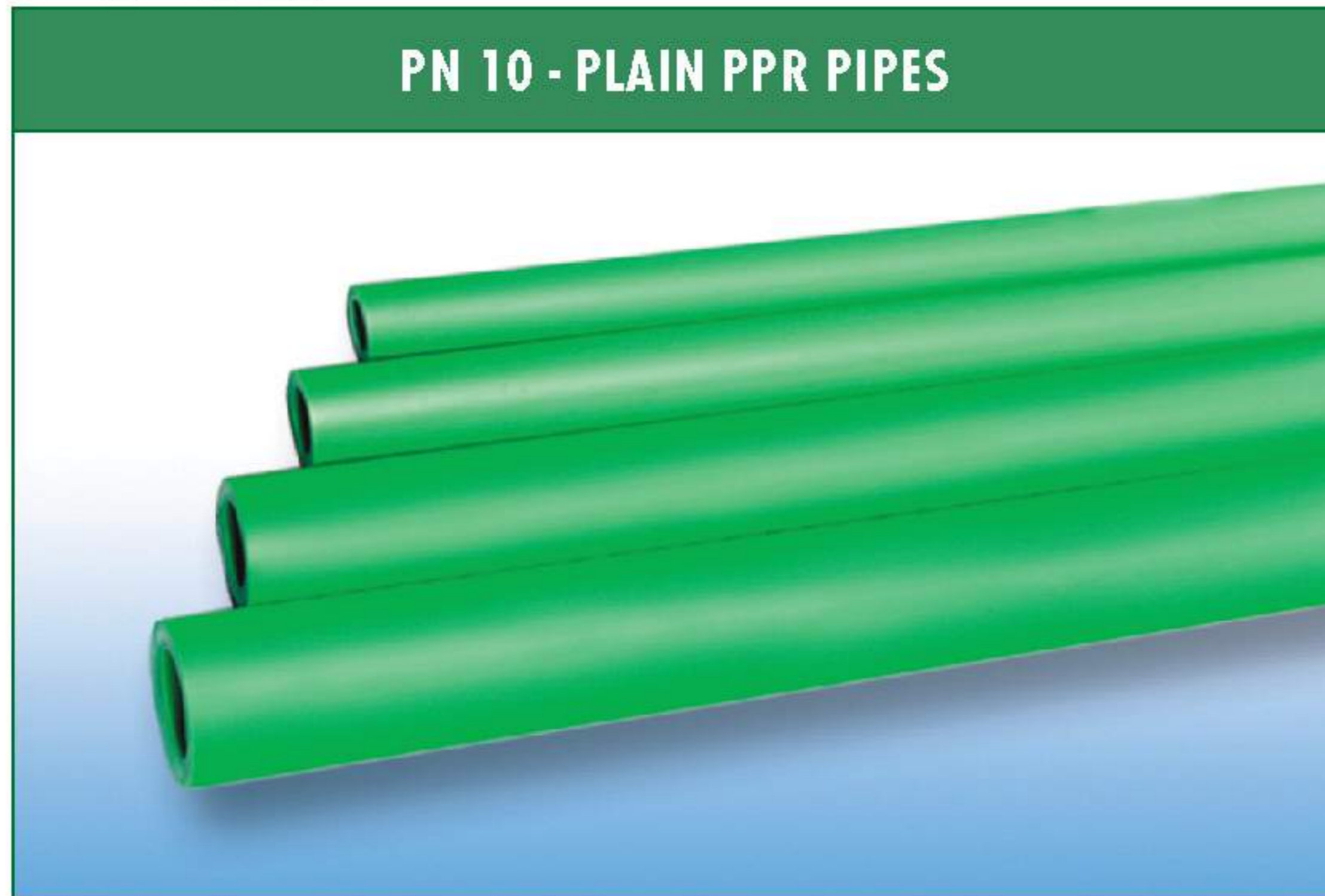

Art. No.	Outside Diameter	Wall Thickness (mm)
PP 10 / 20	20	1.9
PP 10 / 25	25	2.3
PP 10 / 32	32	2.9
PP 10 / 40	40	3.7
PP 10 / 50	50	4.6
PP 10 / 63	63	5.8
PP 10 / 75	75	6.8
PP 10 / 90	90	8.2
PP 10 / 110	110	10.0
PP 10 / 125	125	11.4
PP 10 / 160	160	14.6

PN 16 - PLAIN PPR PIPES

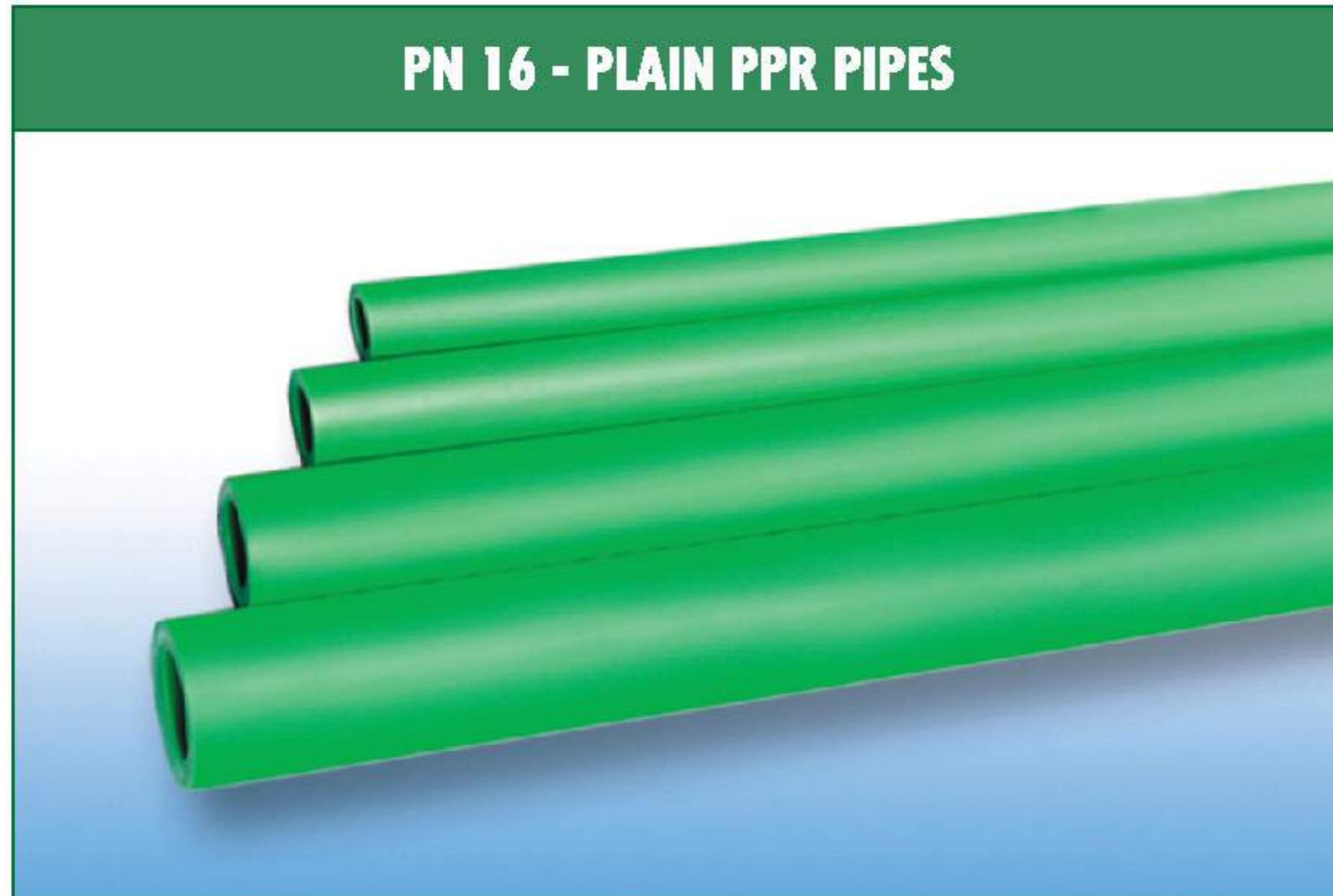

Art. No.	Outside Diameter	Wall Thickness (mm)
PP 16 / 20	20	2.8
PP 16 / 25	25	3.5
PP 16 / 32	32	4.4
PP 16 / 40	40	5.5
PP 16 / 50	50	6.9
PP 16 / 63	63	8.6
PP 16 / 75	75	10.3
PP 16 / 90	90	12.3
PP 16 / 110	110	15.1
PP 16 / 125	125	17.1
PP 16 / 160	160	21.9

PN 20 - PLAIN PPR PIPES

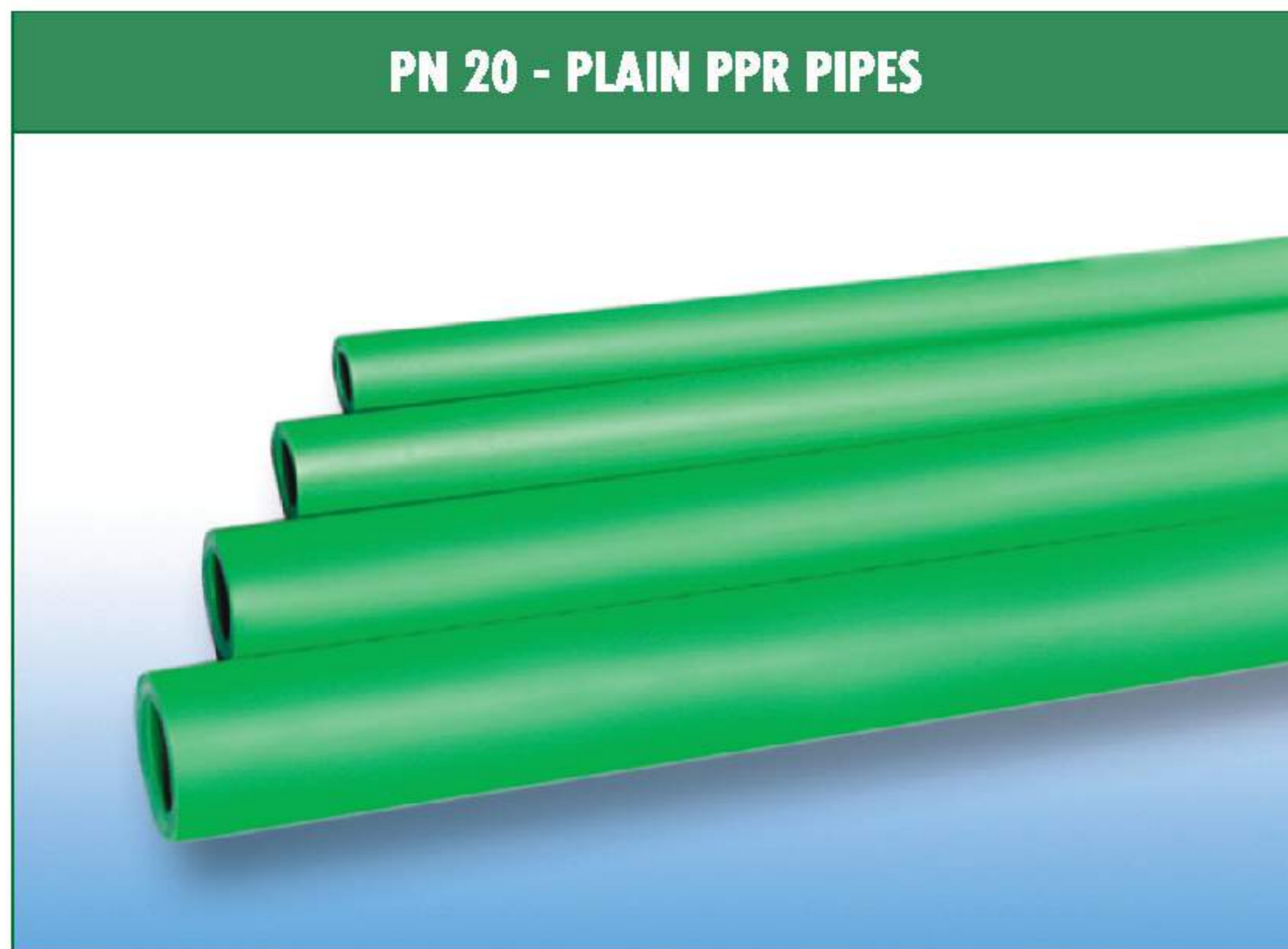

Art. No.	Outside Diameter	Wall Thickness (mm)
PP 20 / 20	20	3.4
PP 20 / 25	25	4.2
PP 20 / 32	32	5.4
PP 20 / 40	40	6.7
PP 20 / 50	50	8.3
PP 20 / 63	63	10.5
PP 20 / 75	75	12.5
PP 20 / 90	90	15.0
PP 20 / 110	110	18.3
PP 20 / 125	125	20.8
PP 20 / 160	160	26.6

PN 25 - PPR/AL/PPR STABI PIPES



Art. No.	Outside Diameter	Wall Thickness (mm)
PS 25 / 20	20	3.4
PS 25 / 25	25	4.2
PS 25 / 32	32	5.4
PS 25 / 40	40	6.7
PS 25 / 50	50	8.3
PS 25 / 63	63	10.5
PS 25 / 75	75	12.5
PS 25 / 90	90	15.0
PS 25 / 110	110	18.3



PN 25 - PPR/AL / PE UV RESISTANT PIPES



PN20 PPR/FG/PPR FASER PIPES

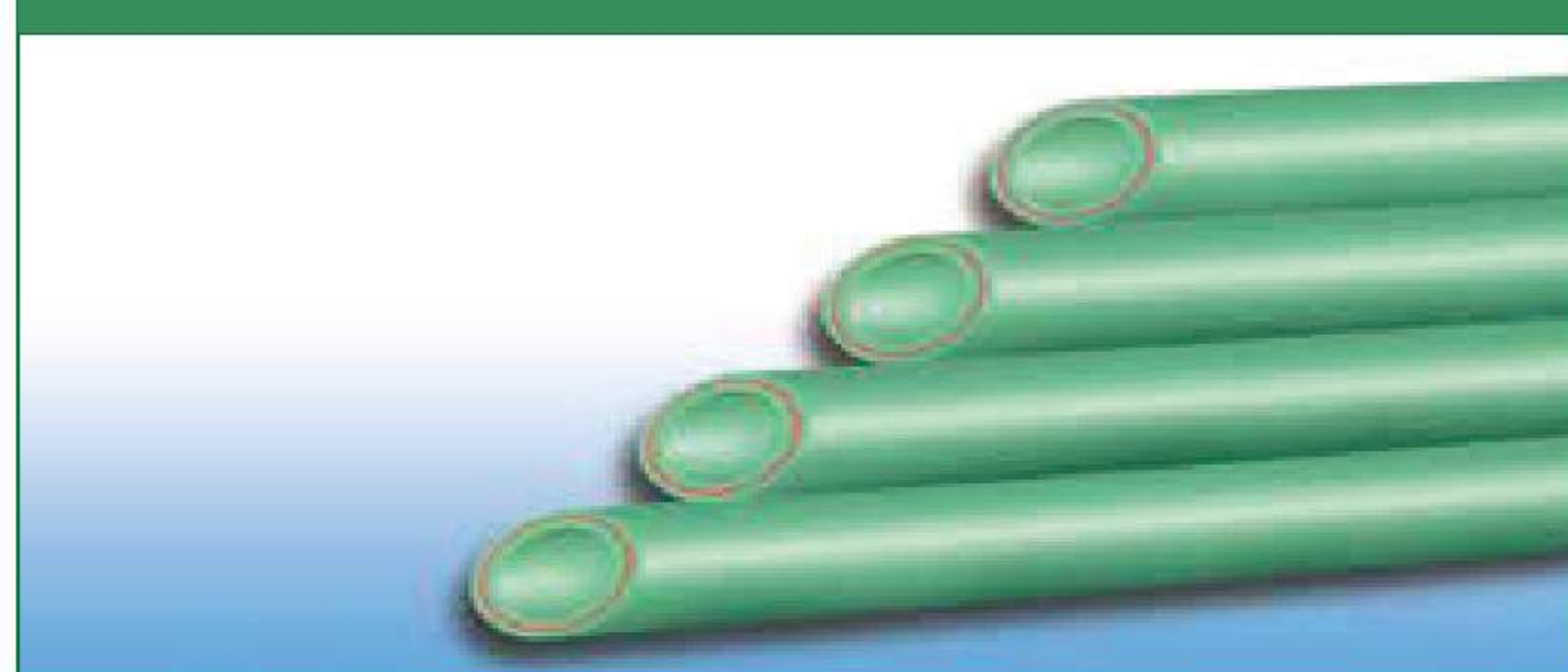

PN 20 PPR FG PPR UV RESISTANT PIPE

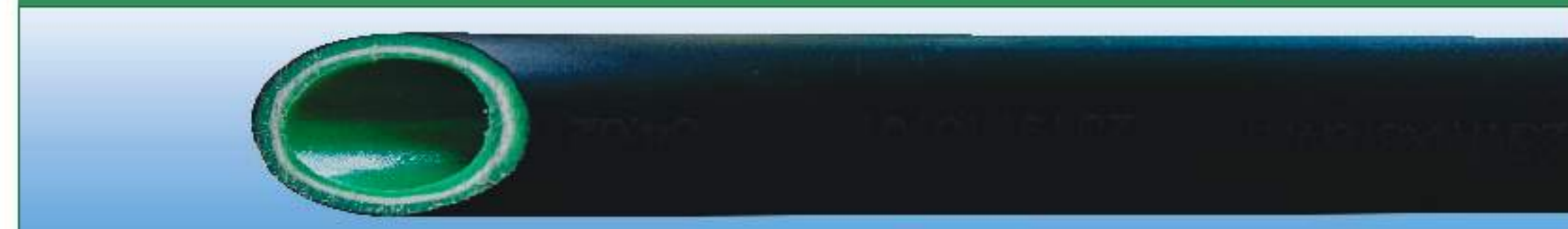

* PN 20 PPR FG PPR UV Resistant Pipes are available for sizes up to 110mm only

PN25 PPR / FG / PPR FASER PIPES

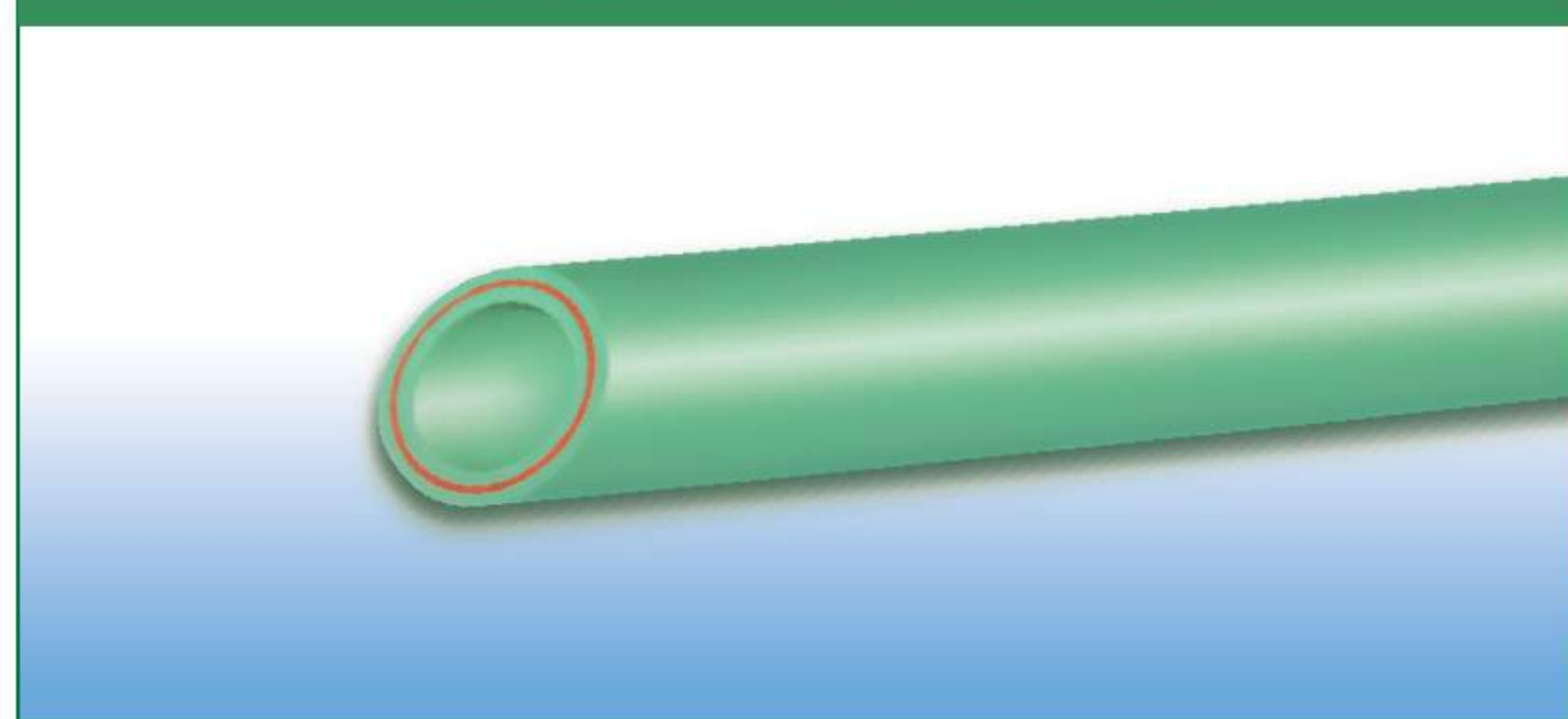

PN 25 PPR FITTINGS

STRAIGHT SOCKET



Art. No.	Outside Diameter	Wall Thickness (mm)
PSU 25 / 25	20	3.4
PSU 25 / 25	25	4.2
PSU 25 / 32	32	5.4
PSU 25 / 40	40	6.7
PSU 25 / 50	50	8.3
PSU 25 / 63	63	10.5

Art. No.	Outside Diameter	Wall Thickness (mm)
PF 20 - 20	20	2.8
PF 20 - 25	25	3.5
PF 20 - 32	32	4.4
PF 20 - 40	40	5.5
PF 20 - 50	50	6.9
PF 20 - 63	63	8.6
PF 75 - 10.4	75	10.3
PF 90 - 12.5	90	12.3
PF 110 - 15.2	110	15.1
PF 125 x 17.1	125	17.1
PF 160 x 21.9	160	21.9

PIPE DATA	* DIAMETER	*WALL THICKNESS
DIMENSION	d (mm)	s (mm)
20 x 3.4	20	3.4
25 x 4.2	25	4.2
32 x 5.4	32	5.4
40 x 6.7	40	6.7
50 x 8.3	50	8.3
63 x 10.5	63	10.5
75 x 12.5	75	12.5
90 x 15.0	90	15.0
110 x 18.3	110	18.3
125 x 20.8	125	20.8
160 x 26.6	160	26.6

Art. No.	Outside Diameter	Qty / Carton
P - S - 20	20	800
P - S - 25	25	504
P - S - 32	32	273
P - S - 40	40	180
P - S - 50	50	80
P - S - 63	63	78
P - S - 75	75	36
P - S - 90	90	24
P - S - 110	110	10
P - S - 125	125	8
P - S - 160	160	6

90° ELBOW



Art. No.	Size (mm)	Qty / Carton
P - E90 - 20	20	450
P - E90 - 25	25	240
P - E90 - 32	32	150
P - E90 - 40	40	80
P - E90 - 50	50	40
P - E90 - 63	63	36
P - E90 - 75	75	22
P - E90 - 90	90	8
P - E90 - 110	110	4
P - E90 - 125	125	3
P - E90 - 160	160	2

45° ELBOW



Art. No.	Size (mm)	Qty / Carton
P - E45 - 20	20	650
P - E45 - 25	25	400
P - E45 - 32	32	216
P - E45 - 40	40	120
P - E45 - 50	50	60
P - E45 - 63	63	24
P - E45 - 75	75	22
P - E45 - 90	90	12
P - E45 - 110	110	6
P - E45 - 125	125	4
P - E45 - 160	160	2

EQUAL TEE



Art. No.	Size (mm)	Qty / Carton
P - T - 20	20	320
P - T - 25	25	195
P - T - 32	32	121
P - T - 40	40	64
P - T - 50	50	36
P - T - 63	63	24
P - T - 75	75	16
P - T - 90	90	10
P - T - 110	110	4
P - T - 125	125	3
P - T - 160	160	2



REDUCING TEE



Art. No.	Size (mm)	Qty / Carton
P - T - 252025	25 x 20 x 25	220
P - T - 252020	25 x 20 x 20	285
P - T - 252520	25 x 25 x 20	350
P - T - 322032	32 x 20 x 32	135
P - T - 322532	32 x 25 x 32	126
P - T - 402040	40 x 20 x 40	100
P - T - 402540	40 x 25 x 40	80
P - T - 403240	40 x 32 x 40	80
P - T - 502050	50 x 20 x 50	60
P - T - 502550	50 x 25 x 50	60
P - T - 503250	50 x 32 x 50	48
P - T - 504050	50 x 40 x 50	40
P - T - 632063	63 x 20 x 63	44
P - T - 632563	63 x 25 x 63	40
P - T - 633263	63 x 32 x 63	32
P - T - 634063	63 x 40 x 63	32
P - T - 635063	63 x 50 x 63	30
P - T - 753275	75 x 32 x 75	20
P - T - 754075	75 x 40 x 75	20
P - T - 755075	75 x 50 x 75	26
P - T - 756375	75 x 63 x 75	18
P - T - 903290	90 x 32 x 90	18
P - T - 904090	90 x 40 x 90	12
P - T - 905090	90 x 50 x 90	12
P - T - 906390	90 x 63 x 90	12
P - T - 907590	90 x 75 x 90	12
P - T - 11050110	110 x 50 x 110	8
P - T - 11063110	110 x 63 x 110	10
P - T - 11075110	110 x 75 x 110	6
P - T - 11090110	110 x 90 x 110	5
P - T - 160110160	160 x 110 x 160	2

REDUCER BUSH M x F



Art. No.	Size (mm)	Qty / Carton
P - RB - 2520	25 x 20	810
P - RB - 3220	32 x 20	600
P - RB - 3225	32 x 25	480

REDUCER SOCKET F X F



Art. No.	Size (mm)	Qty / Carton
P - RS - 2520	25 x 20	560
P - RS - 3220	32 x 20	390
P - RS - 3225	32 x 25	360
P - RS - 4020	40 x 20	200
P - RS - 4025	40 x 25	200
P - RS - 4032	40 x 32	144
P - RS - 5020	50 x 20	200
P - RS - 5025	50 x 25	120
P - RS - 5032	50 x 32	120
P - RS - 5040	50 x 40	90
P - RS - 6320	63 x 20	80
P - RS - 6325	63 x 25	80
P - RS - 6332	63 x 32	80
P - RS - 6340	63 x 40	80
P - RS - 6350	63 x 50	60
P - RS - 7532	75 x 32	60
P - RS - 7540	75 x 40	60
P - RS - 7550	75 x 50	60
P - RS - 7563	75 x 63	40
P - RS - 9032	90 x 32	40
P - RS - 9040	90 x 40	36
P - RS - 9050	90 x 50	36
P - RS - 9063	90 x 63	36
P - RS - 9075	90 x 75	24
P - RS - 11050	110 x 50	20
P - RS - 11063	110 x 63	20
P - RS - 11075	110 x 75	20
P - RS - 11090	110 x 90	15
P - RS - 125110	125 x 110	10
P - RS - 160110	160 x 110	8
P - RS - 160125	160 x 125	6

END CAP



Art. No.	Size (mm)	Qty / Carton
P - EC - 20	20	1200
P - EC - 25	25	612
P - EC - 32	32	315
P - EC - 40	40	200
P - EC - 50	50	160
P - EC - 63	63	80
P - EC - 75	75	48
P - EC - 90	90	32
P - EC - 110	110	20
P - EC - 125	125	14
P - EC - 160	160	7



CROSS



Art. No.	Size (mm)	Qty / Carton
P - CR - 20	20	300
P - CR - 32	32	100
P - CR - 40	40	60

BYPASS BEND



Art. No.	Outside Diameter	Qty / Carton
P - BB - 20	20	80
P - BB - 25	25	100
P - BB - 32	32	60

SHORT BRIDGE



Art. No.	Size (mm)	Qty / Carton
P - SB - 20	20	300
P - SB - 25	25	180
P - SB - 32	32	100

LONG BRIDGE



Art. No.	Size (mm)	Qty / Carton
P - LB - 20	20	250
P - LB - 25	25	100
P - LB - 32	32	55

MALE THREADED SOCKET



Art. No.	Size (mm)	Qty / Carton
P - MS - 20½"	20 x ½"	150
P - MS - 20¾"	20 x ¾"	100
P - MS - 25½"	25 x ½"	150
P - MS - 25¾"	25 x ¾"	120
P - MS - 32½"	32 x ½"	100
P - MS - 32¾"	32 x ¾"	90
P - MS - 321"	32 x 1"	60
P - MS - 401¼"	40 x 1¼"	30
P - MS - 501½"	50 x 1½"	24
P - MS - 632"	63 x 2"	12
P - MS - 752½"	75 x 2½"	8
P - MS - 903"	90 x 3"	6
P - MS - 1104"	110 x 4"	4

FEMALE THREADED SOCKET

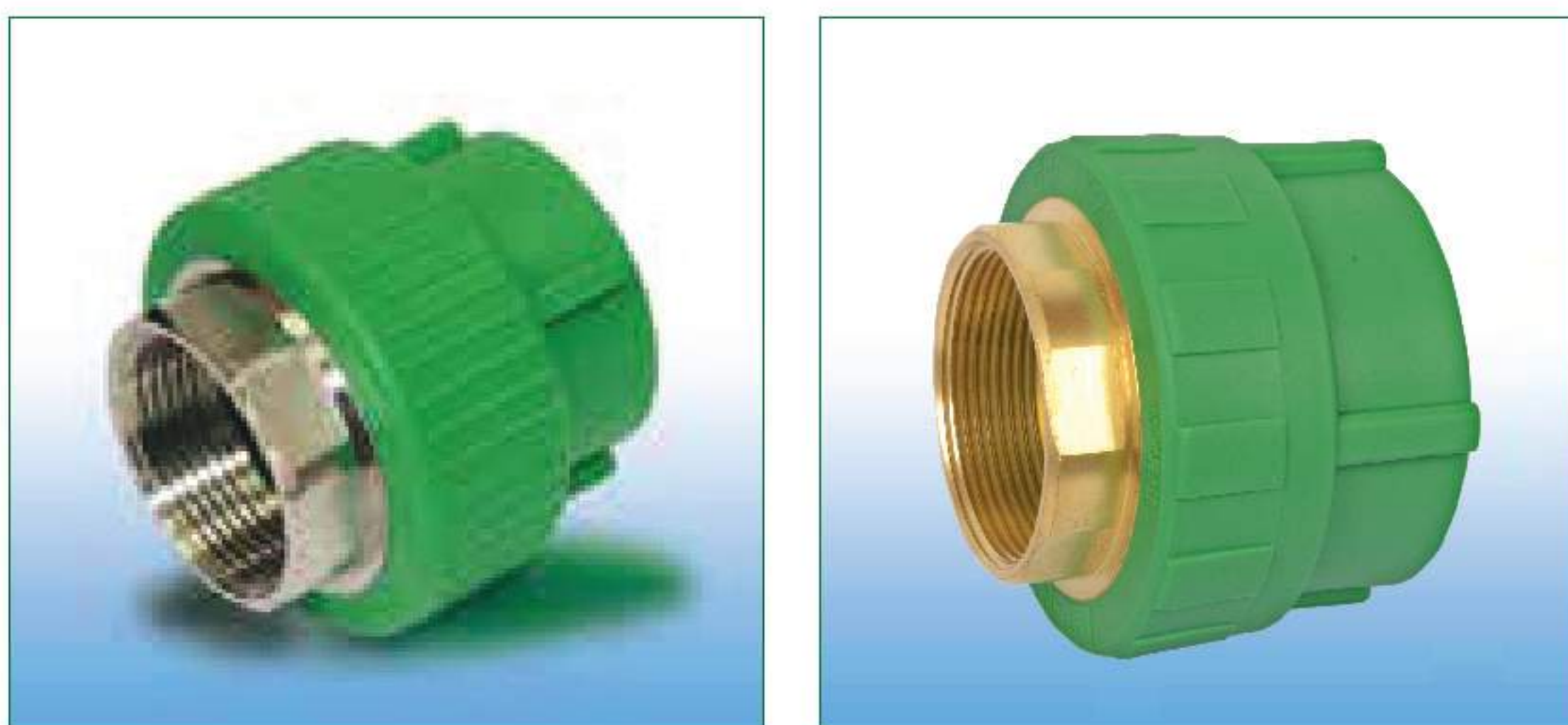

Art. No.	Size (mm)	Qty / Carton
P - FS - 20½"	20 x ½"	200
P - FS - 20¾"	20 x ¾"	150
P - FS - 25½"	25 x ½"	180
P - FS - 25¾"	25 x ¾"	150
P - FS - 32½"	32 x ½"	120
P - FS - 32¾"	32 x ¾"	120
P - FS - 321"	32 x 1"	70
P - FS - 401¼"	40 x 1¼"	35
P - FS - 501½"	50 x 1½"	24
P - FS - 632"	63 x 2"	14
P - FS - 752½"	75 x 2½"	8
P - FS - 903"	90 x 3"	12
P - FS - 1104"	110 x 4"	7

90° MALE THREADED ELBOW

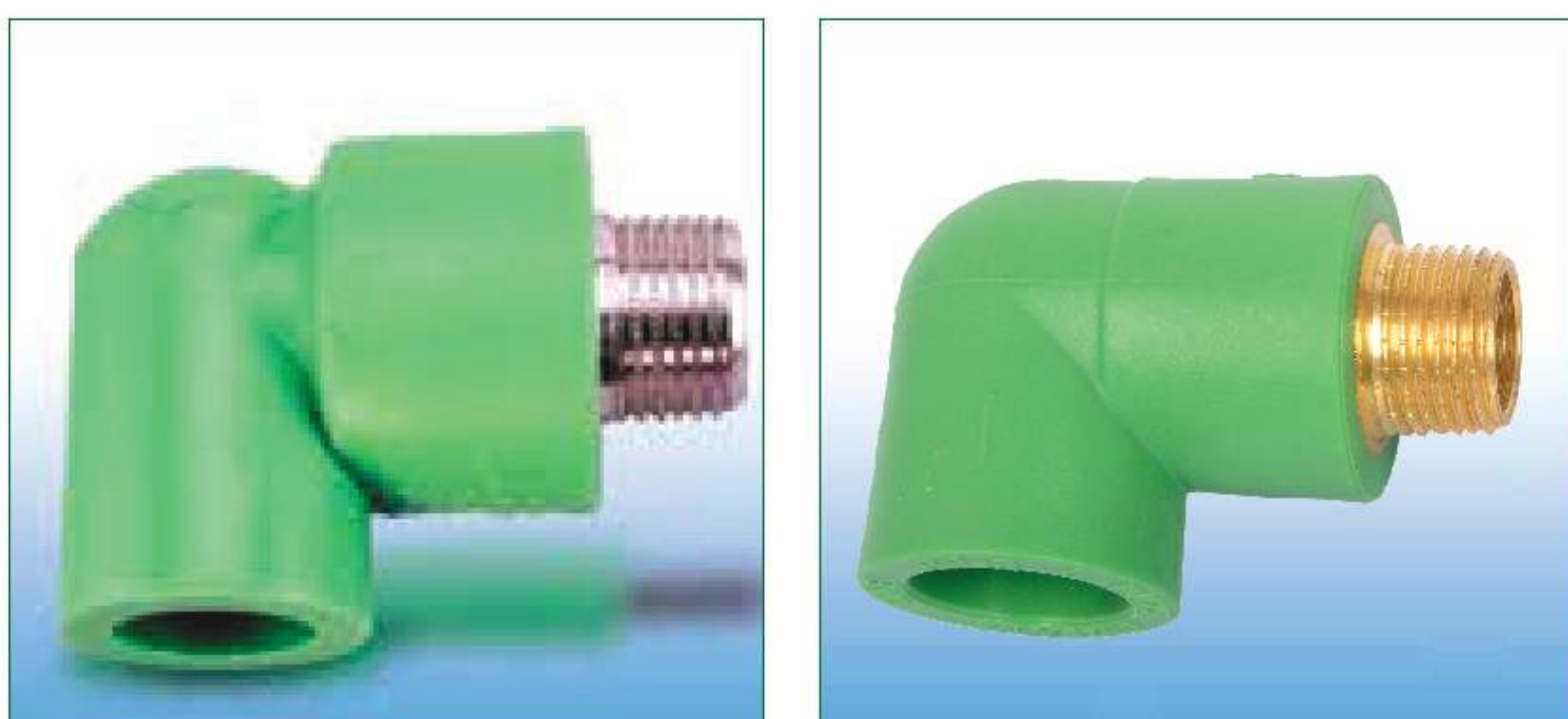

Art. No.	Size (mm)	Qty / Carton
P - ME - 20½"	20 x ½"	120
P - ME - 20¾"	20 x ¾"	100
P - ME - 25½"	25 x ½"	100
P - ME - 25¾"	25 x ¾"	90
P - ME - 321"	32 x 1"	50

* Threads are available in brass and nickel plated brass options
 * All threads are BSPT



FEMALE THREADED ELBOW



Art. No.	Size (mm)	Qty / Carton
P - FE - 20½	20 x ½"	140
P - FE - 20¾	20 x ¾"	160
P - FE - 25½	25 x ½"	120
P - FE - 25¾	25 x ¾"	100
P - FE - 32½	32 x ½"	90
P - FE - 32¾	32 x ¾"	70
P - FE - 321	32 x 1"	50

90° FEMALE THREADED WALL ELBOW



Art. No.	Size (mm)	Qty / Carton
P - WE - 20½	20 x ½"	100
P - WE - 25½	25 x ½"	70
P - WE - 25¾	25 x ¾"	160

MALE THREADED TEE

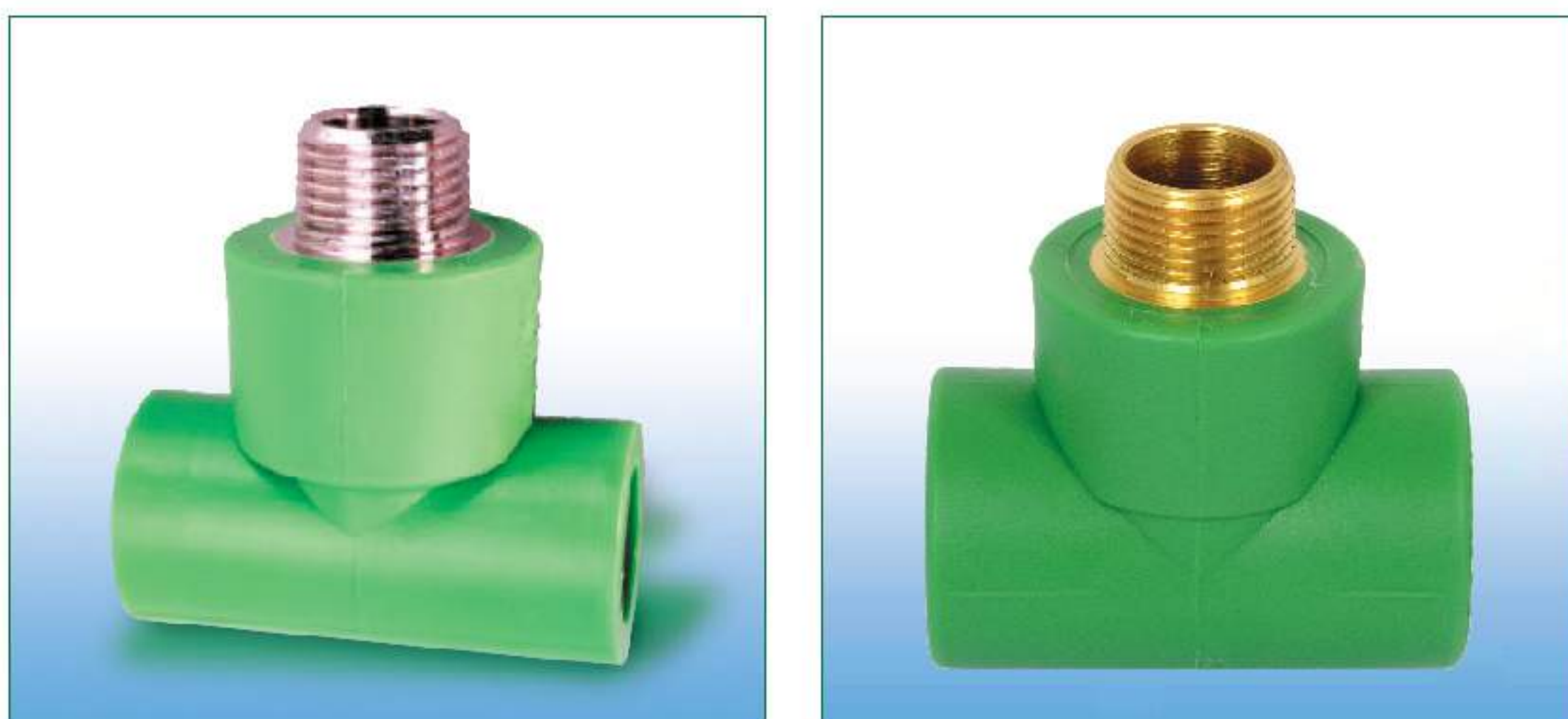

Art. No.	Size (mm)	Qty / Carton
P - MT - 20½	20 x ½"	200
P - MT - 25½	25 x ½"	90
P - MT - 25¾	25 x ¾"	75
P - MT - 32½	32 x ½"	560
P - MT - 32¾	32 x ¾"	600
P - MT - 321	32 x 1"	760

WALL MOUNTING GROUP



Art. No.	Size (mm)	Qty / Carton
P - WG - 20½	20 x ½"	21
P - WG - 25½	25 x ½"	15

* Threads are available in brass and nickel plated brass options
 * All threads are BSPT

FEMALE THREADED TEE



Art. No.	Size (mm)	Qty / Carton
P - FT - 20½	20 x ½"	120
P - FT - 20¾	20 x ¾"	160
P - FT - 25½	25 x ½"	100
P - FT - 25¾	25 x ¾"	160
P - FT - 32½	32 x ½"	60
P - FT - 32¾	32 x ¾"	50
P - FT - 321	32 x 1"	40

PPR BRASS UNION

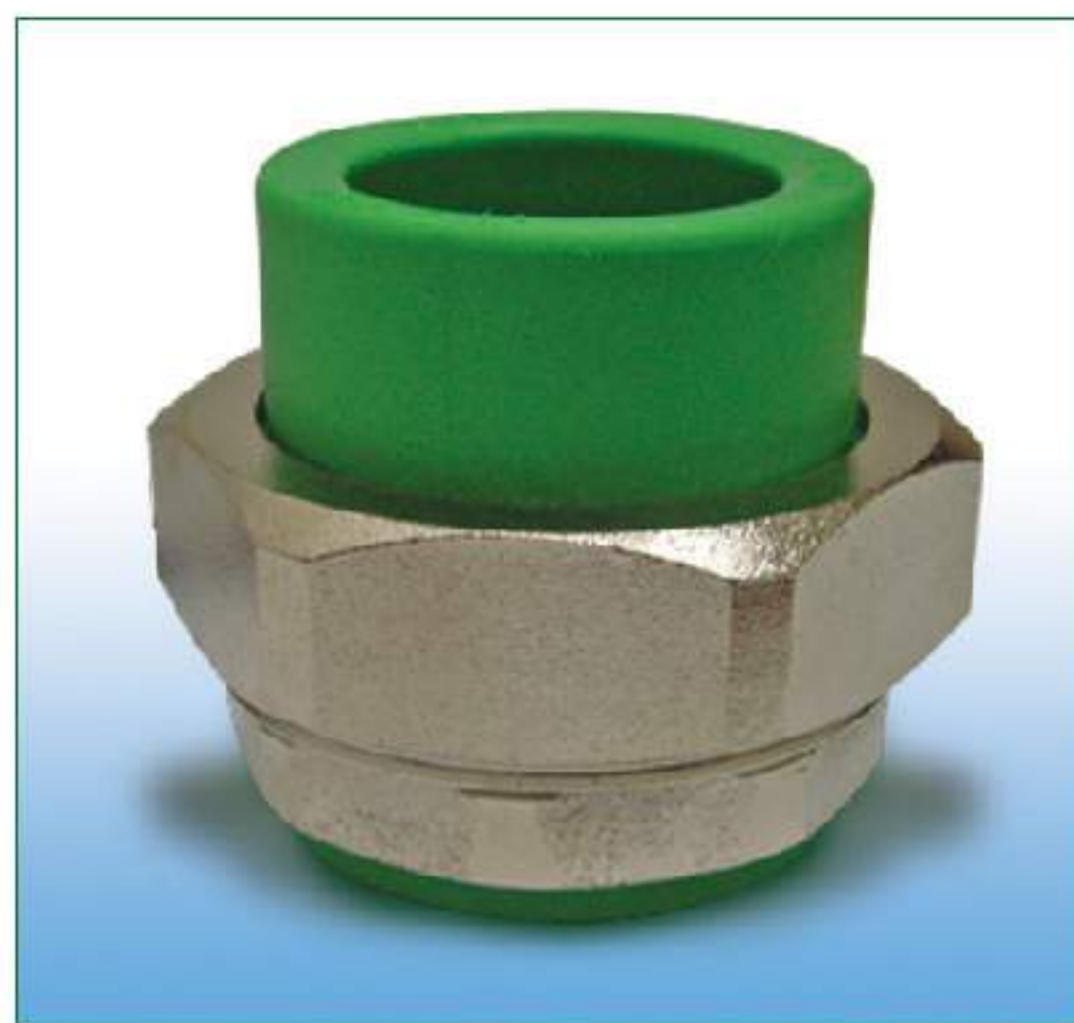

Art. No.	Size (mm)	Qty / Carton
P - BU - 20½	½" x 20	300
P - BU - 401¼	1¼" x 40	40
P - BU - 501½	1½" x 50	20

MALE UNION



Art. No.	Size (mm)	Qty / Carton
P - MU - 20½	½" x 20	150
P - MU - 25¾	¾" x 25	100
P - MU - 321	1" x 32	70
P - MU - 401¼	1¼" x 40	35
P - MU - 501½	1½" x 50	28
P - MU - 632	2" x 63	12

FEMALE UNION

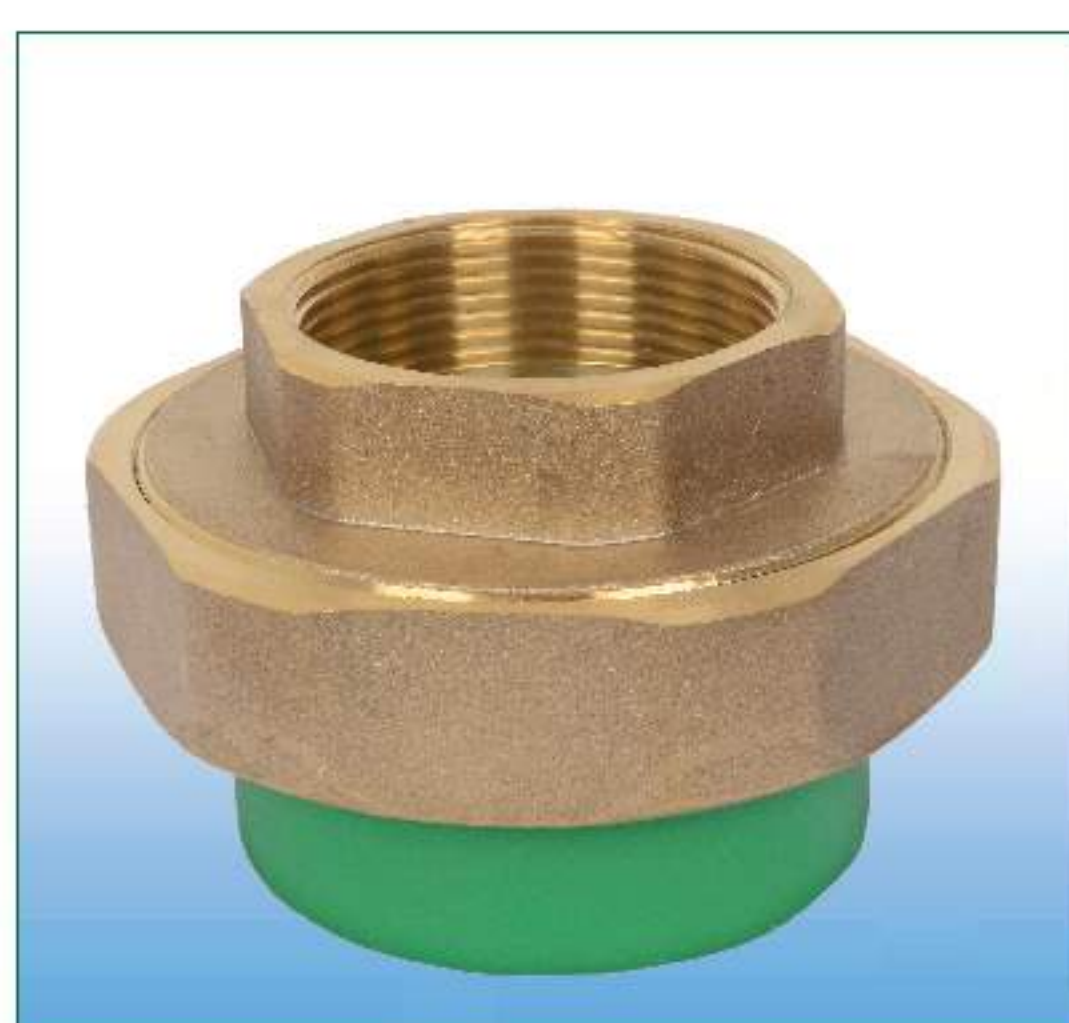

Art. No.	Size (mm)	Qty / Carton
P - FU - 20½	½" x 20	180
P - FU - 25¾	¾" x 25	120
P - FU - 321	1" x 32	70
P - FU - 401¼	1¼" x 40	40
P - FU - 501½	1½" x 50	40
P - FU - 632	2" x 63	16

* Threads are available in brass and nickel plated brass options
 * All threads are BSPT



PP-R UNION



Art. No.	Size (mm)	Qty / Carton
P - PU - 20	20	300
P - PU - 25	25	150
P - PU - 32	32	108
P - PU - 40	40	50
P - PU - 50	50	24
P - PU - 63	63	18

90° ELBOW WITH UNION



Art. No.	Size (mm)	Qty / Carton
P - EU - 321	32 x 1"	-

COUPLING WITH UNION



Art. No.	Size (mm)	Qty / Carton
P - CU - 321½	32 x 1¼"	-

STOP VALVE WITH CHROME HANDLE



Art. No.	Size (mm)	Qty / Carton
P - VCH - 20	20	35
P - VCH - 25	25	20
P - VCH - 32	32	25

* Threads are available in brass and nickel plated brass options
* All threads are BSPT

STOP VALVE WITH CAP



Art. No.	Size (mm)	Qty / Carton
P - VC - 20	20	40
P - VC - 25	25	60

STOP VALVE WITH ROUND HAND WHEEL



Art. No.	Size (mm)	Qty / Carton
P - HWV - 20	20	50
P - HWV - 25	25	40
P - HWV - 32	32	36
P - HWV - 40	40	24
P - HWV - 50	50	12
P - HWV - 63	63	8
P - HWV - 75	75	4
P - HWV - 90	90	3
P - HWV - 110	110	2

PN 20 BALL VALVE WITH LEVER HANDLE (BALL COCK)



Art. No.	Size (mm)	Qty / Carton
P - BC - 20	20	60
P - BC - 25	25	50
P - BC - 32	32	30
P - BC - 40	40	20
P - BC - 50	50	12
P - BC - 63	63	6

PN 20 DOUBLE UNION BALL VALVE



Art. No.	Size (mm)	Qty / Carton
P - DWV - 20	20	50
P - DWV - 25	25	40
P - DWV - 32	32	25
P - DWV - 40	40	16
P - DWV - 50	50	10
P - DWV - 63	63	6



BRASS MALE X FEMALE UNION



Art. No.	Size (mm)	Qty / Carton
P - MFU - 1/2 - 3/4	1/2" M x 3/4" F	-
P - MFU - 3/4 - 1	3/4" x 1" F	-

PPR CLIP



Art. No.	Size (mm)	Qty / Carton
P - PC - 20	20	28,00
P - PC - 25	25	1,500
P - PC - 32	32	1,000
P - PC - 40	40	770
P - PC - 50	50	475
P - PC - 63	63	325

PPR HIGH CLIP



Art. No.	Size (mm)	Qty / Carton
P - HPC - 20	20	800
P - HPC - 25	25	700
P - HPC - 32	32	600
P - HPC - 40	40	700
P - HPC - 50	50	300
P - HPC - 63	63	240

PPR FLANGE SOCKET & ABS BACKING RING

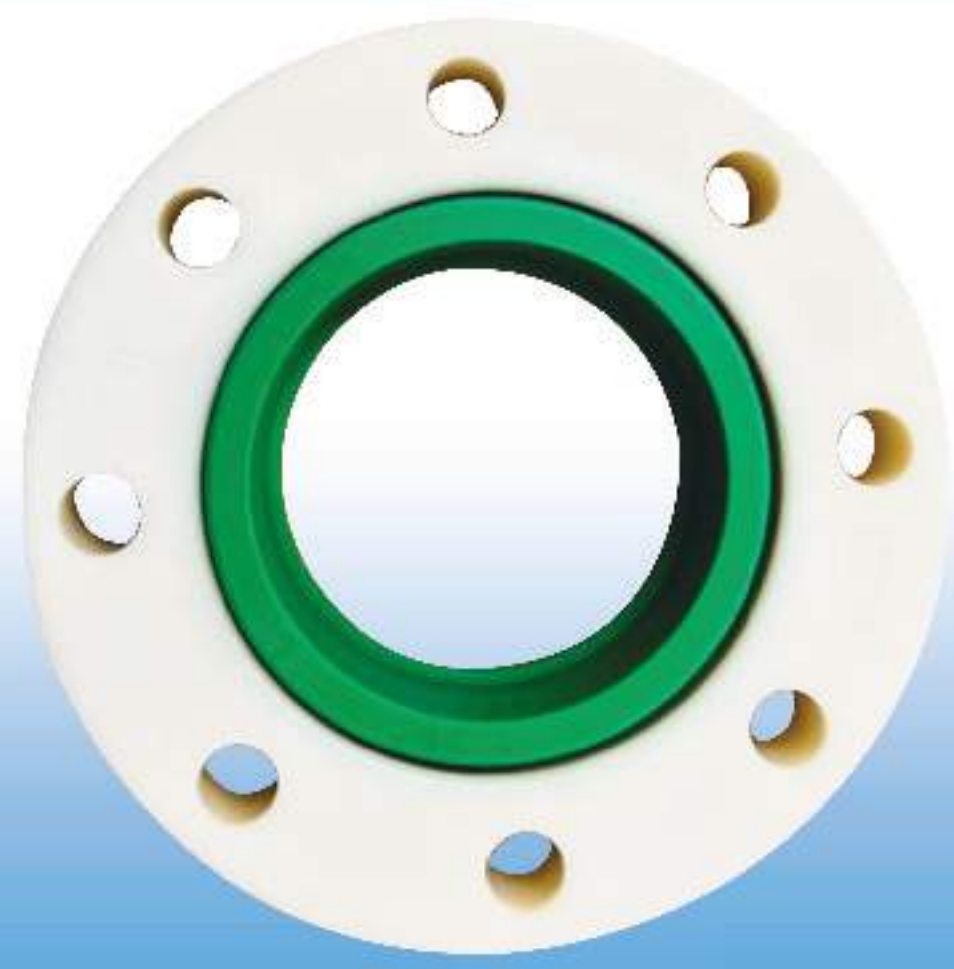

Art. No.	FLANGE SIZE (mm)	NO. OF HOLES
P - FSR - 40	40	4
P - FSR - 50	50	4
P - FSR - 63	63	4
P - FSR - 75	75	4
P - FSR - 90	90	8
P - FSR - 110	110	8
P - FSR - 160	160	8

WELDING MACHINE AND TOOLS (220V)



Art. No.	Size (mm)	Qty / Carton
P - WM - 2063	20-63mm (Including tools 20-40mm)	1
P - WM - 5075	50-110mm (Including tools 50-75mm)	1
P - WM - 110	160mm (Including tools 110-160mm)	1

WELDING MACHINE AND TOOLS (110V)



Art. No.	Size (mm)	Qty / Carton
P - WM - 2063	20-63mm (Including tools 20-40mm)	1
P - WM - 5075	50-110mm (Including tools 50-75mm)	1
P - WM - 110	160mm (Including tools 110-160mm)	1
P - WM - 125	125-160 (Without tools)	1

WELDING TOOL



Art. No.	Size (mm)
P - WT - 20	20
P - WT - 25	25
P - WT - 32	32
P - WT - 40	40
P - WT - 50	50
P - WT - 63	63
P - WT - 75	75
P - WT - 90	90
P - WT - 110	110
P - WT - 125	125
P - WT - 160	160



HOLES REPAIRING KIT



Art. No.	Size (mm)
P - HRK - 9	9mm

ELECTRO - FUSION WELDING MACHINE



Art. No.	Size (mm)	Qty / Carton
P - EFM - 20110	20 - 110	1

ELECTRO-FUSION WELDING SOCKETS



Art. No.	Size (mm)
P - EFS - 20	20
P - EFS - 25	25
P - EFS - 32	32
P - EFS - 40	40
P - EFS - 50	50
P - EFS - 63	63
P - EFS - 75	75
P - EFS - 90	90
P - EFS - 110	110

PIPE CUTTER



Art. No.	Size (mm)
P - PC - 2040	20 - 40

BIG SIZE PIPE CUTTER



Art. No.	Size (mm)
P - PC - 2063	20 - 63

ROLLER PIPE CUTTER



Art. No.	Size (mm)	Qty / Carton
P - RPC - 2063	20 - 63	20
P - RPC - 40110	40 - 110	10

PIPE SHAVERS



Art. No.	Size (mm)
P - PS - 1620	16 - 20
P - PS - 2025	20 - 25
P - PS - 3240	32 - 40
P - PS - 5063	50 - 63
P - PS - 75	75
P - PS - 90	90
P - PS - 110	110

PRESSURE TEST PUMP



Art. No.	Size (mm)	Qty / Carton
P - TP - 0	PRESSURE TEST PUMP	1



TESTING PLUG



Art. No.	Size (mm)	Qty / Carton
P - TP - 1/2R	1/2" RED	320
P - TP - 1/2B	1/2" BLUE	320
P - TP - 1/2G	1/2" GREEN	320

PPR THREADED PLUG



Art. No.	Size (mm)	Qty / Carton
P - PP - 1/2	1/2"	1700
P - PP - 3/4	3/4"	960
P - PP - 1	1"	600

Note: Chemical Resistance Table for Polypropylene can be provided as per customer request.

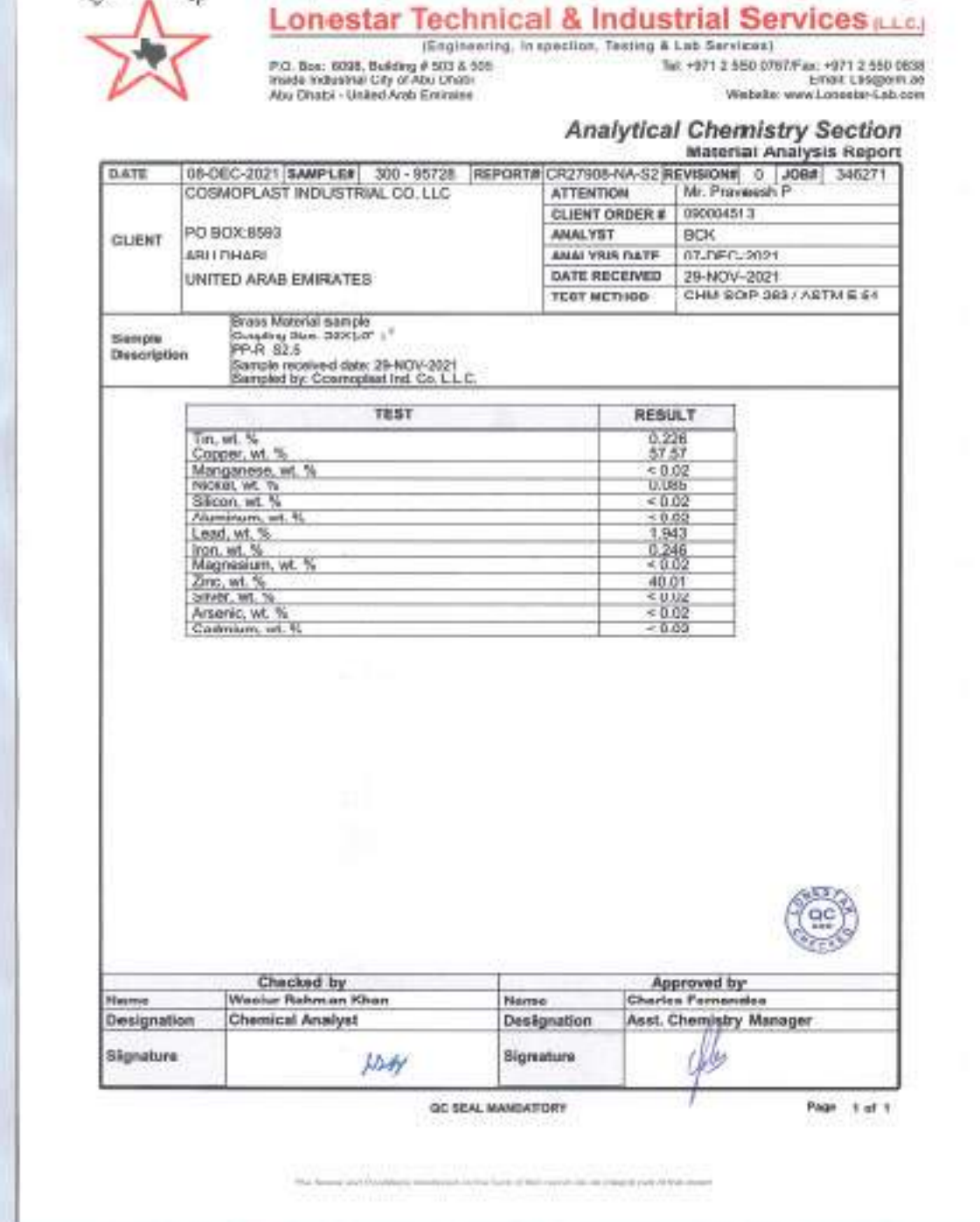
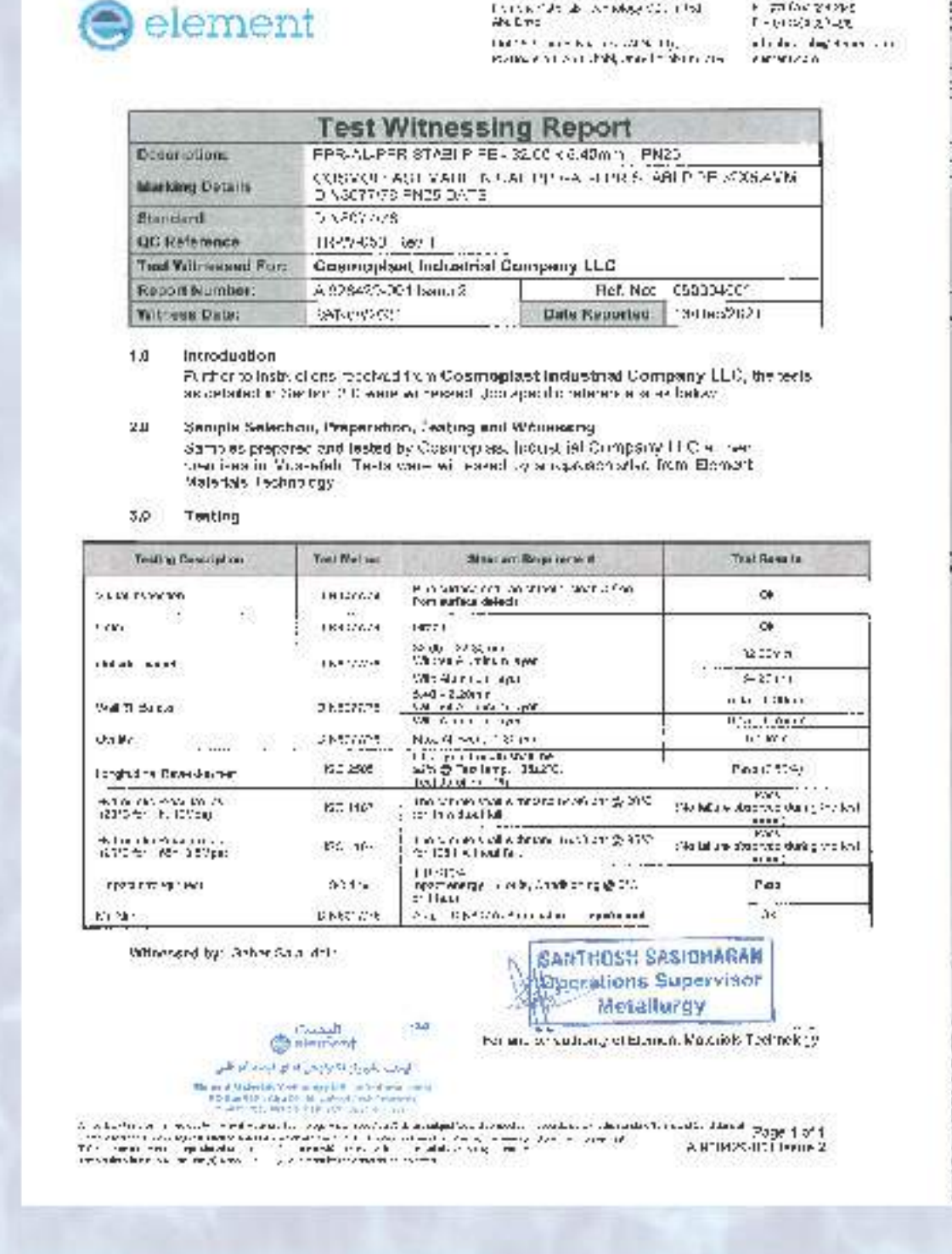
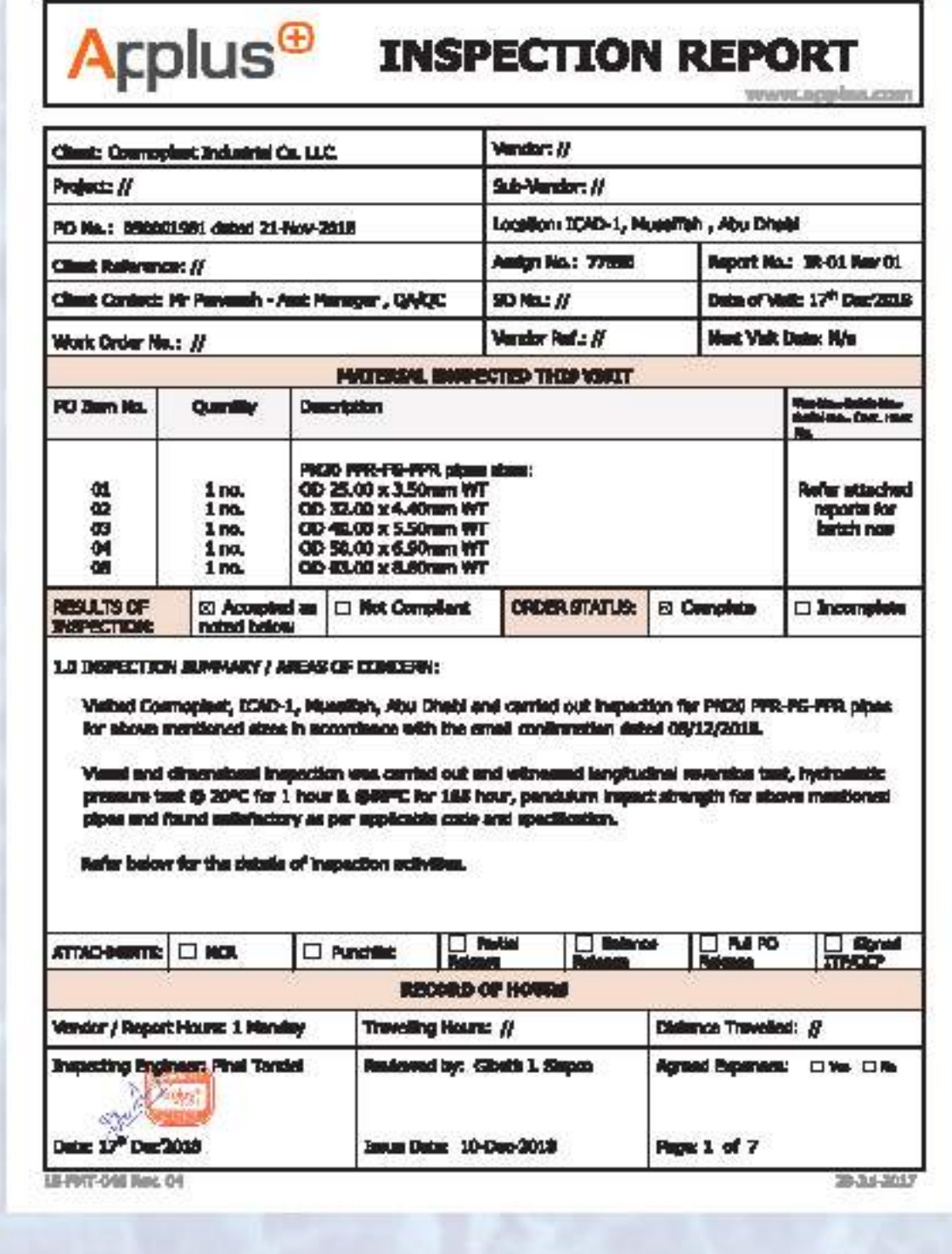
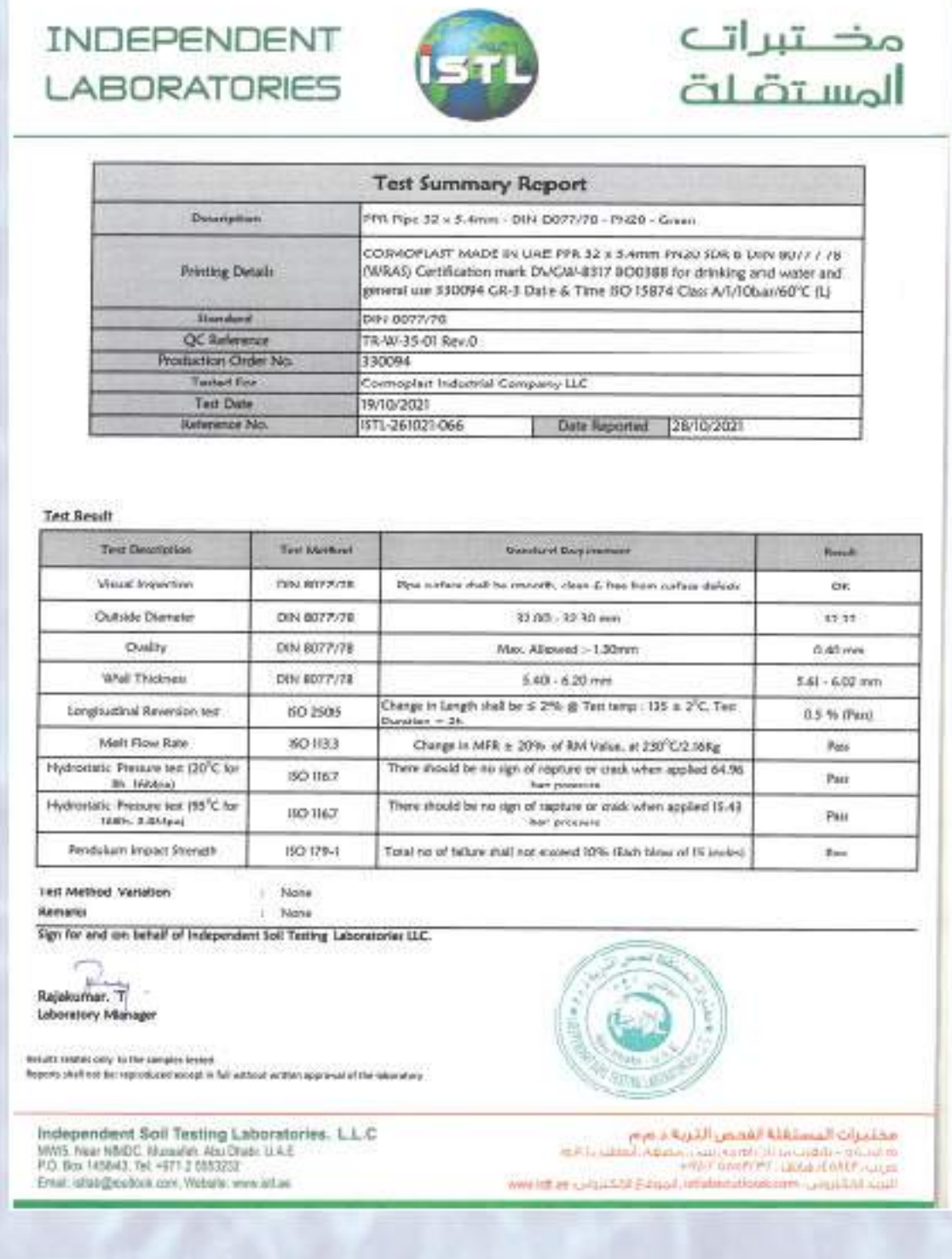
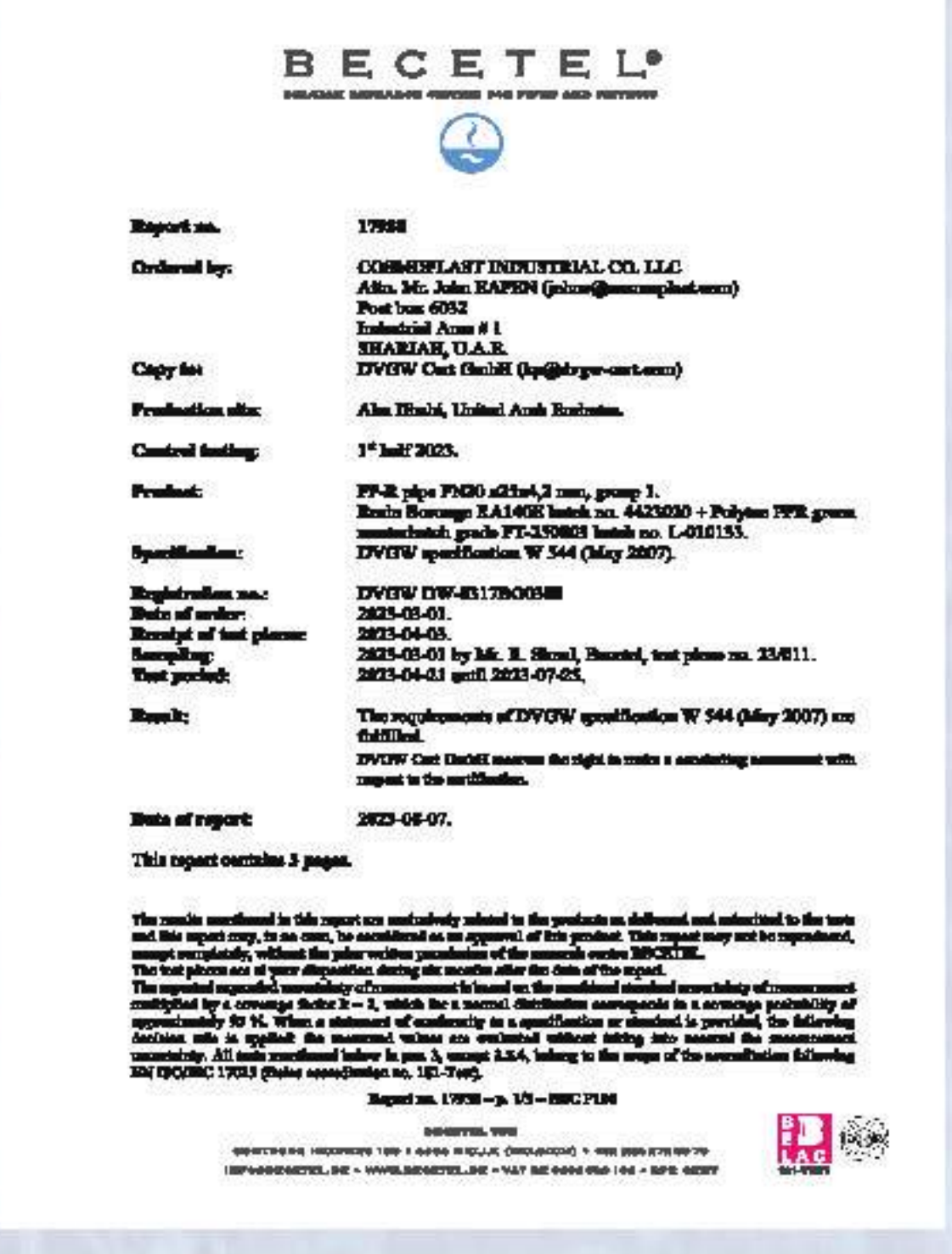
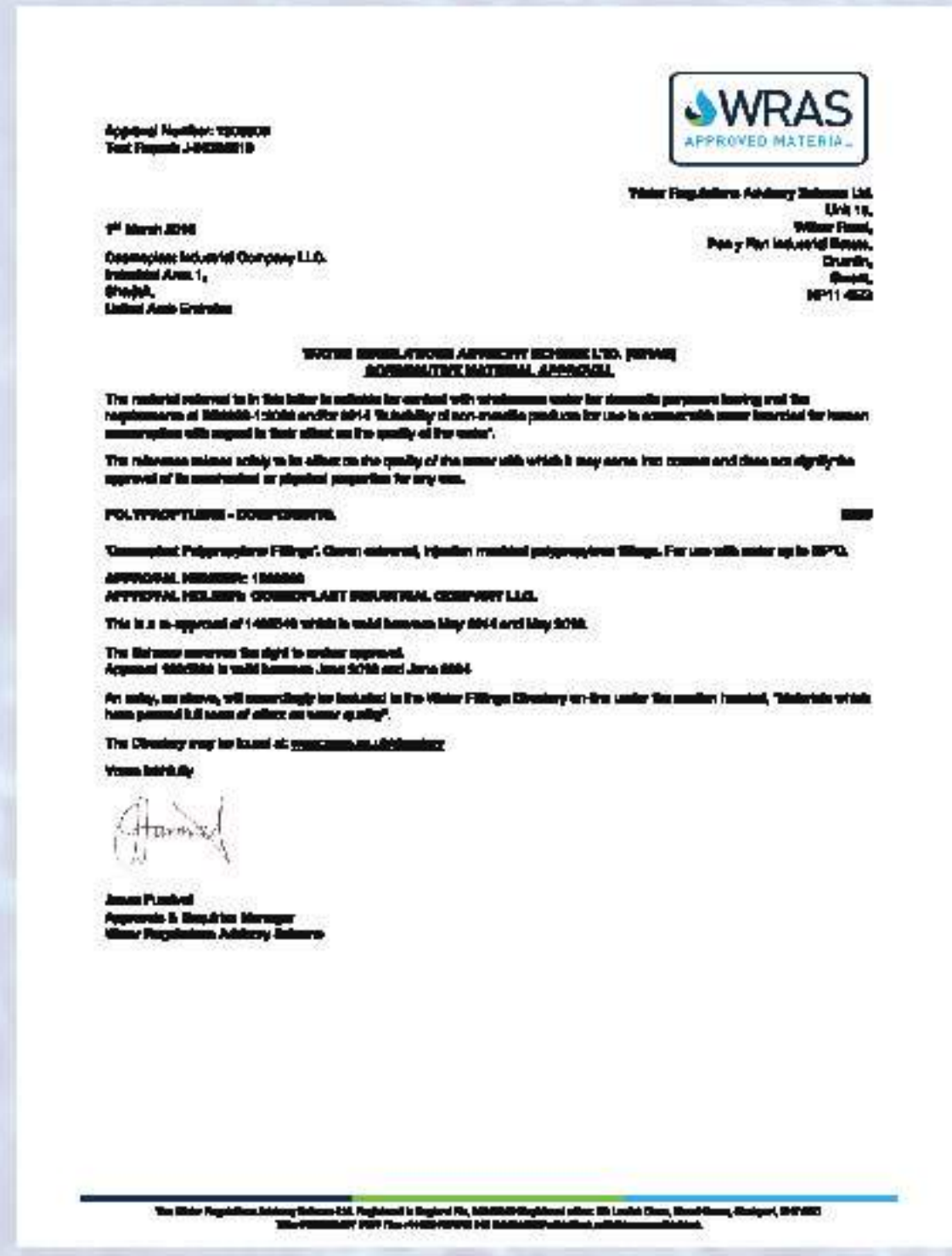
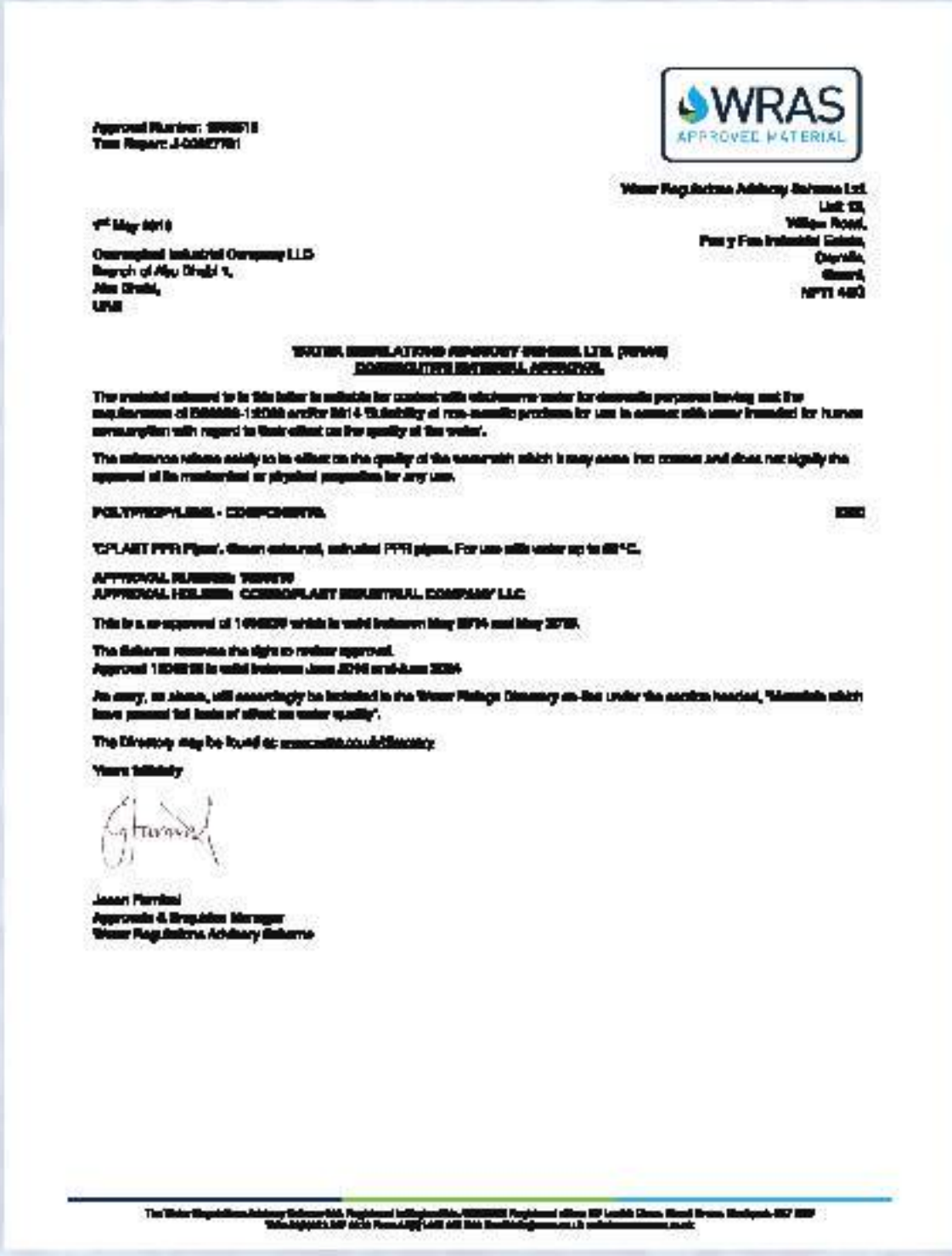

Pipeline Systems

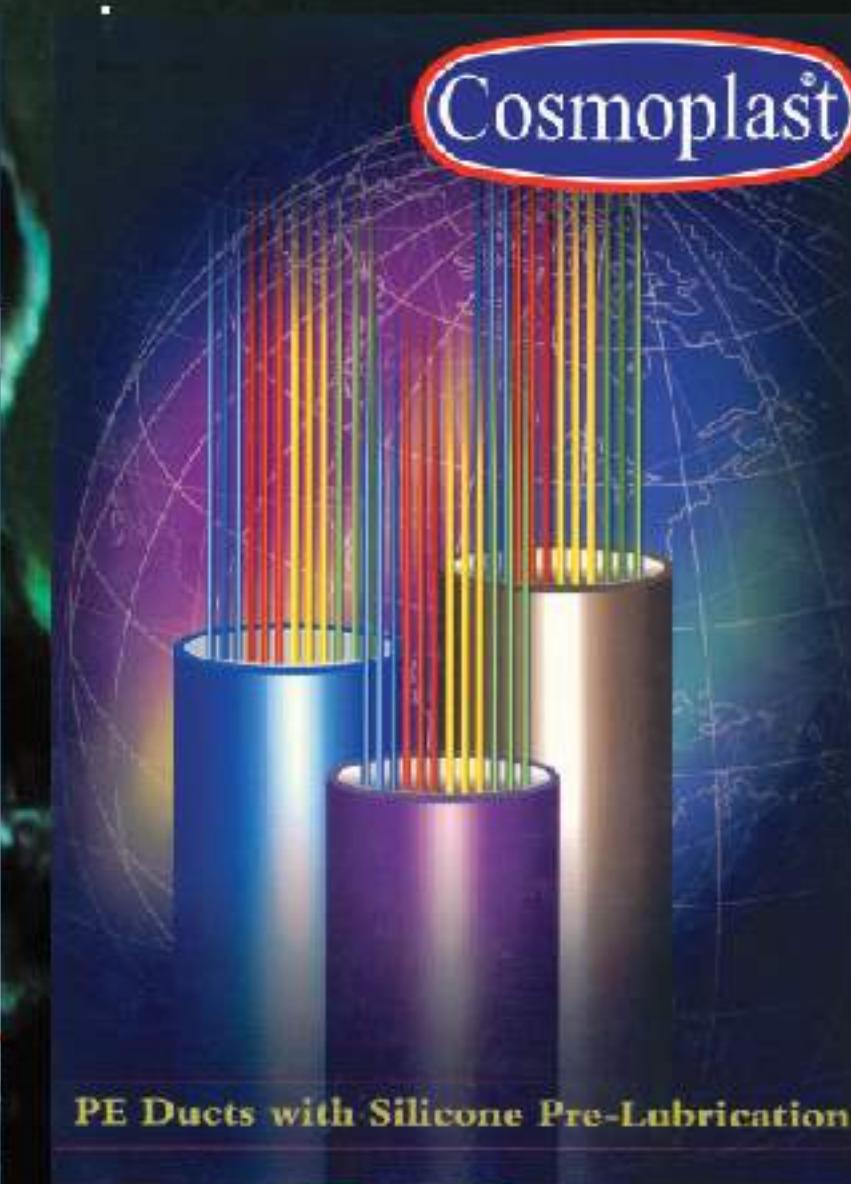
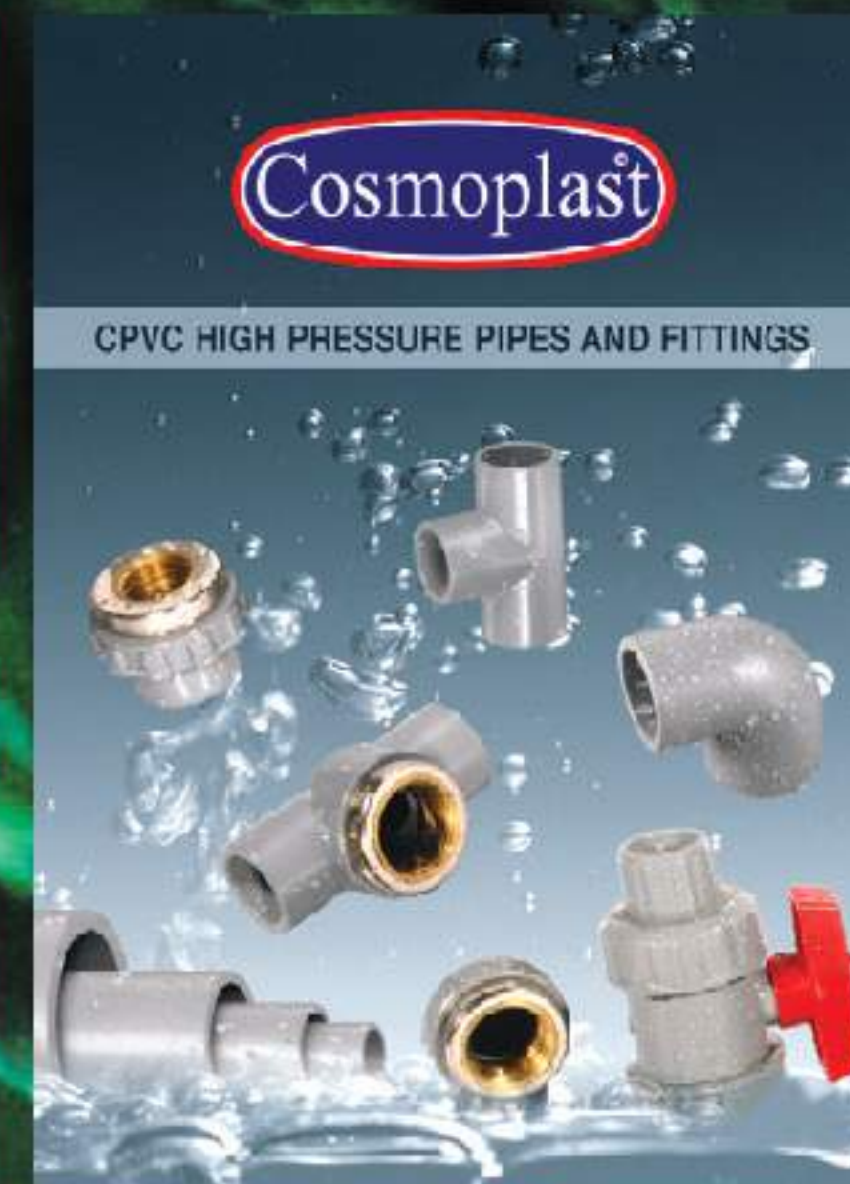
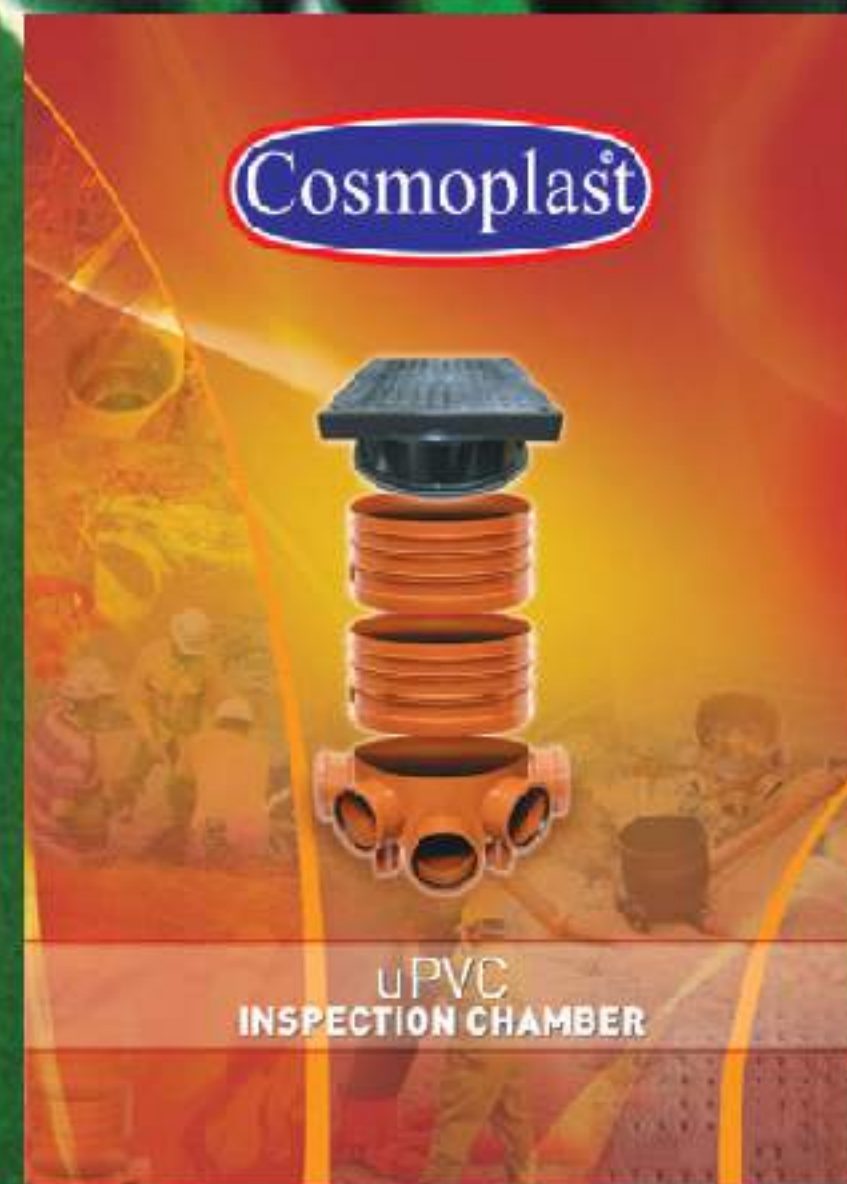
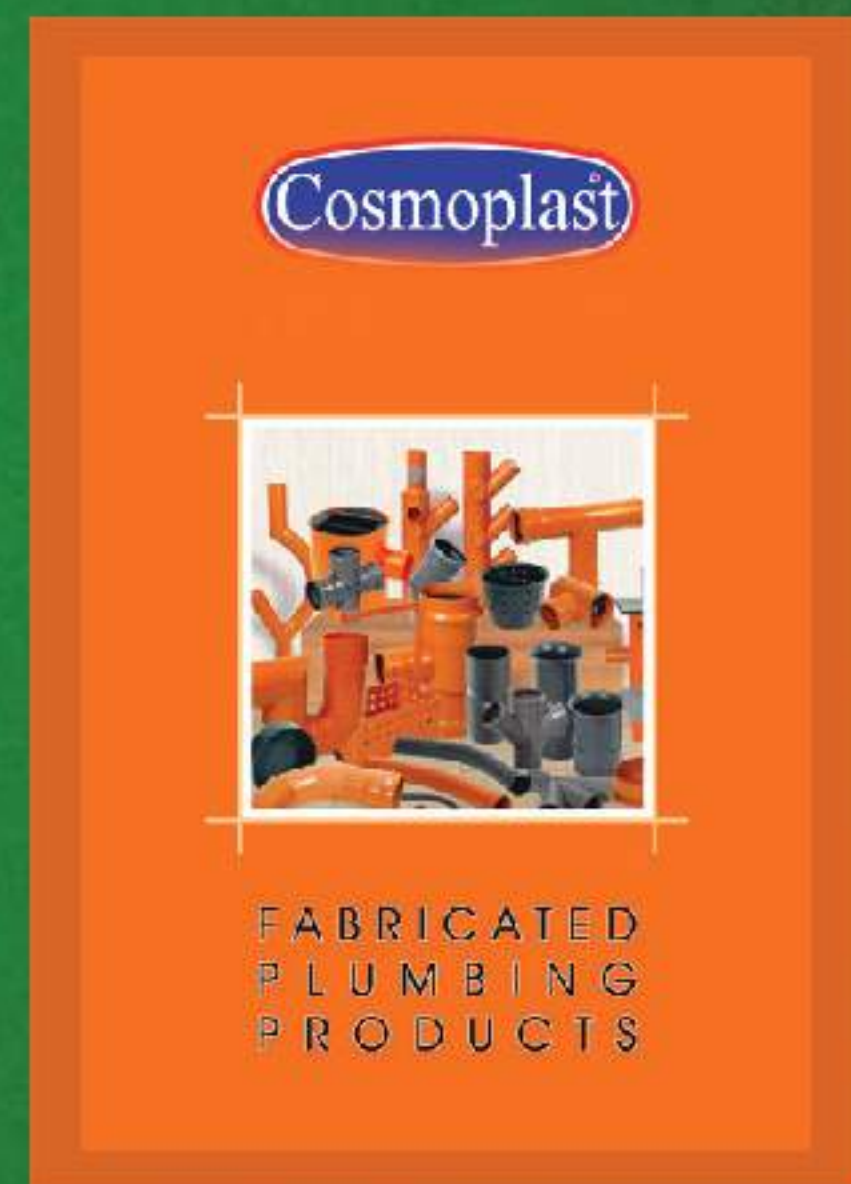
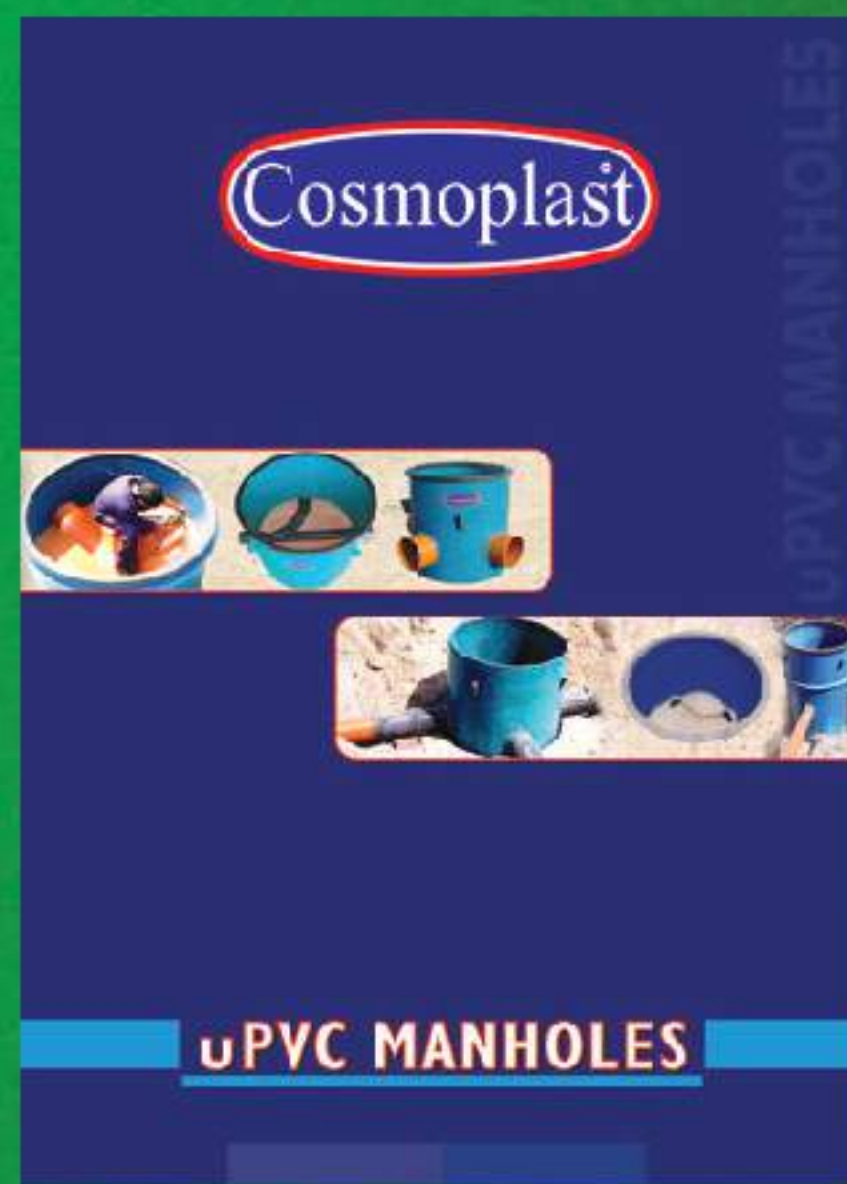
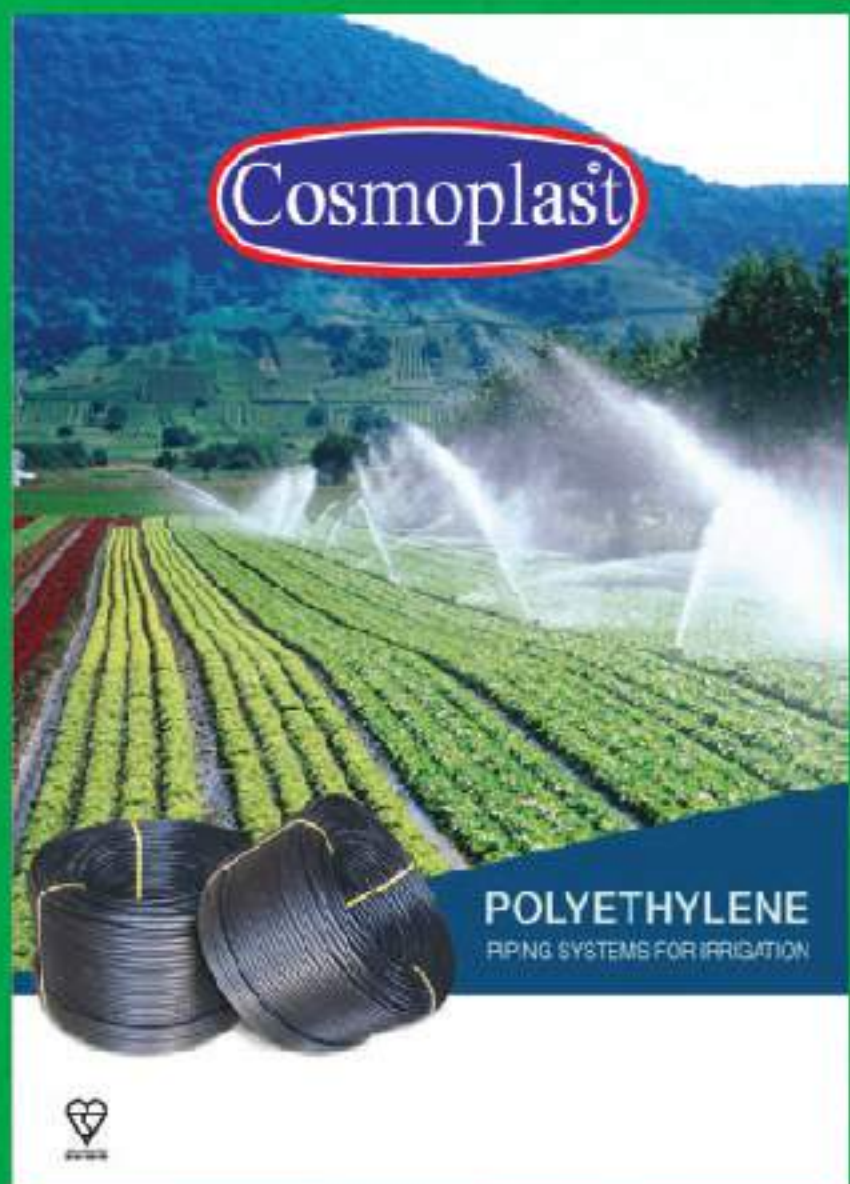
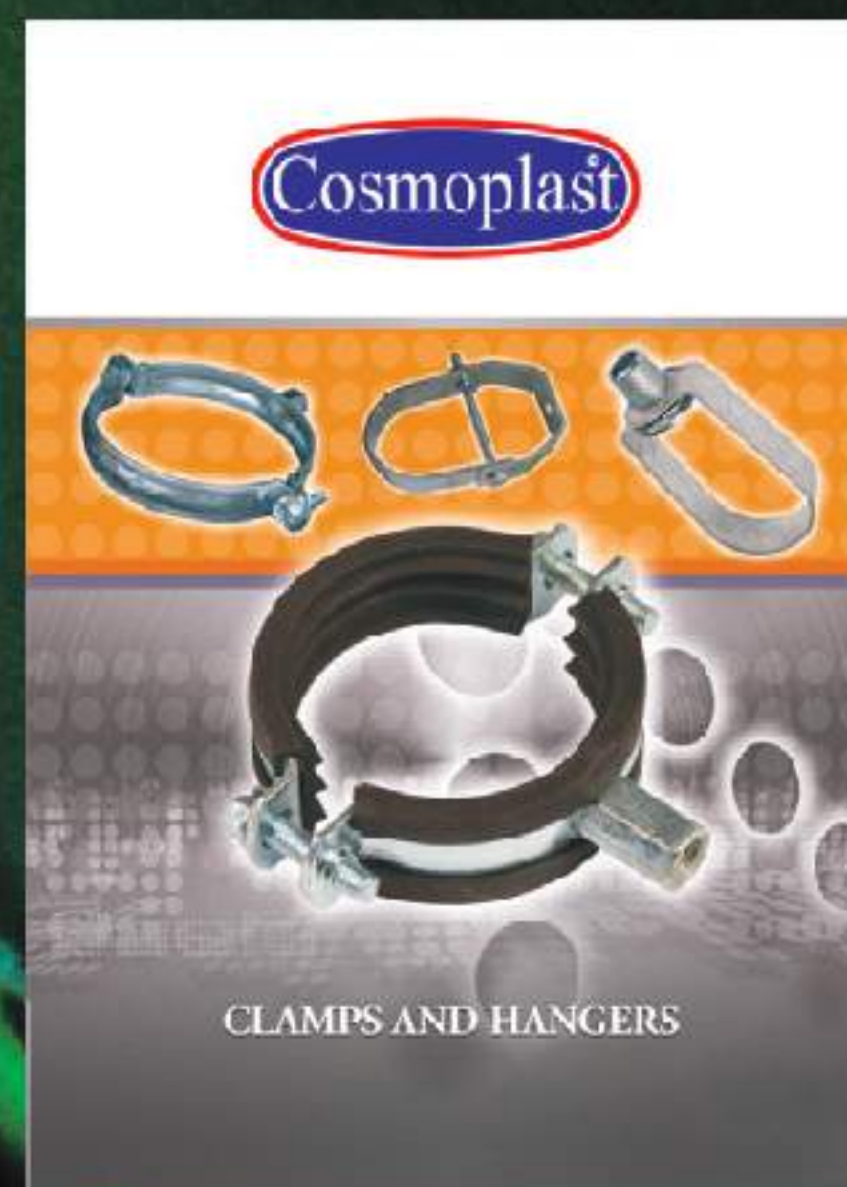
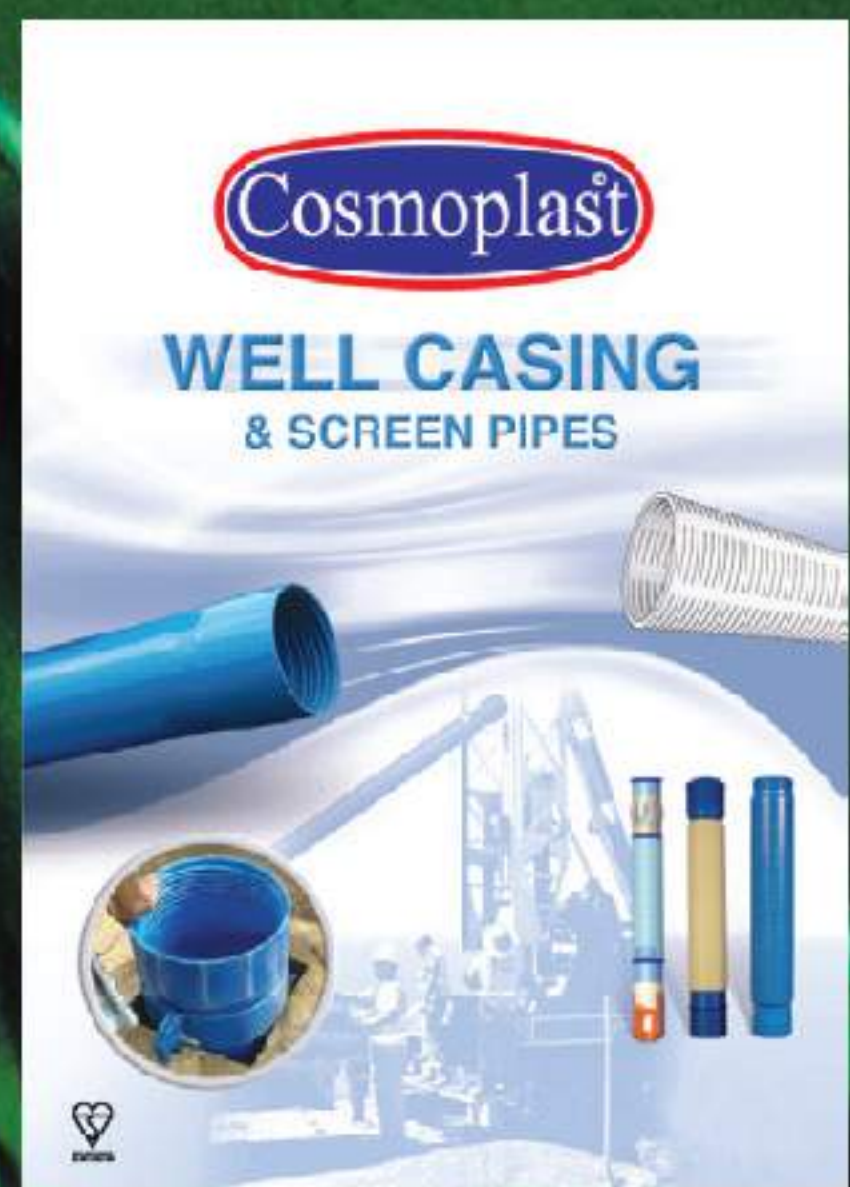
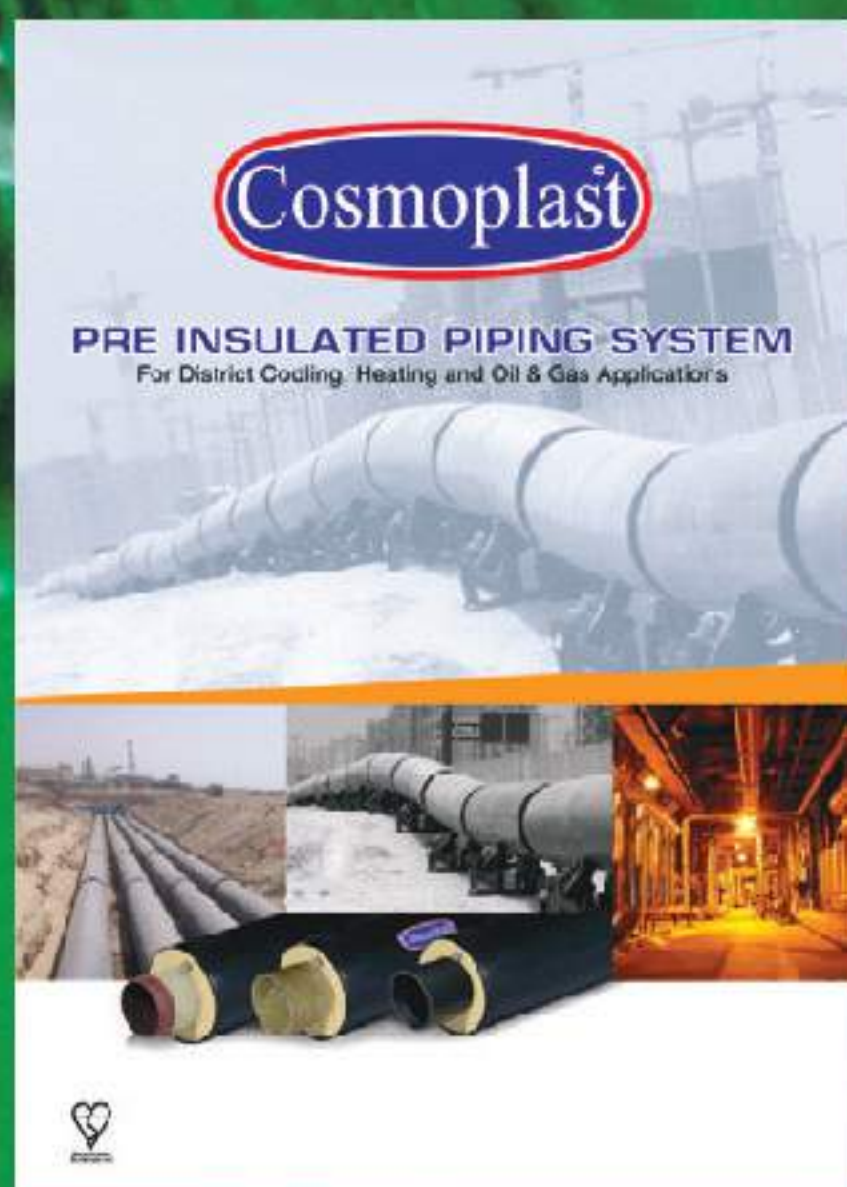
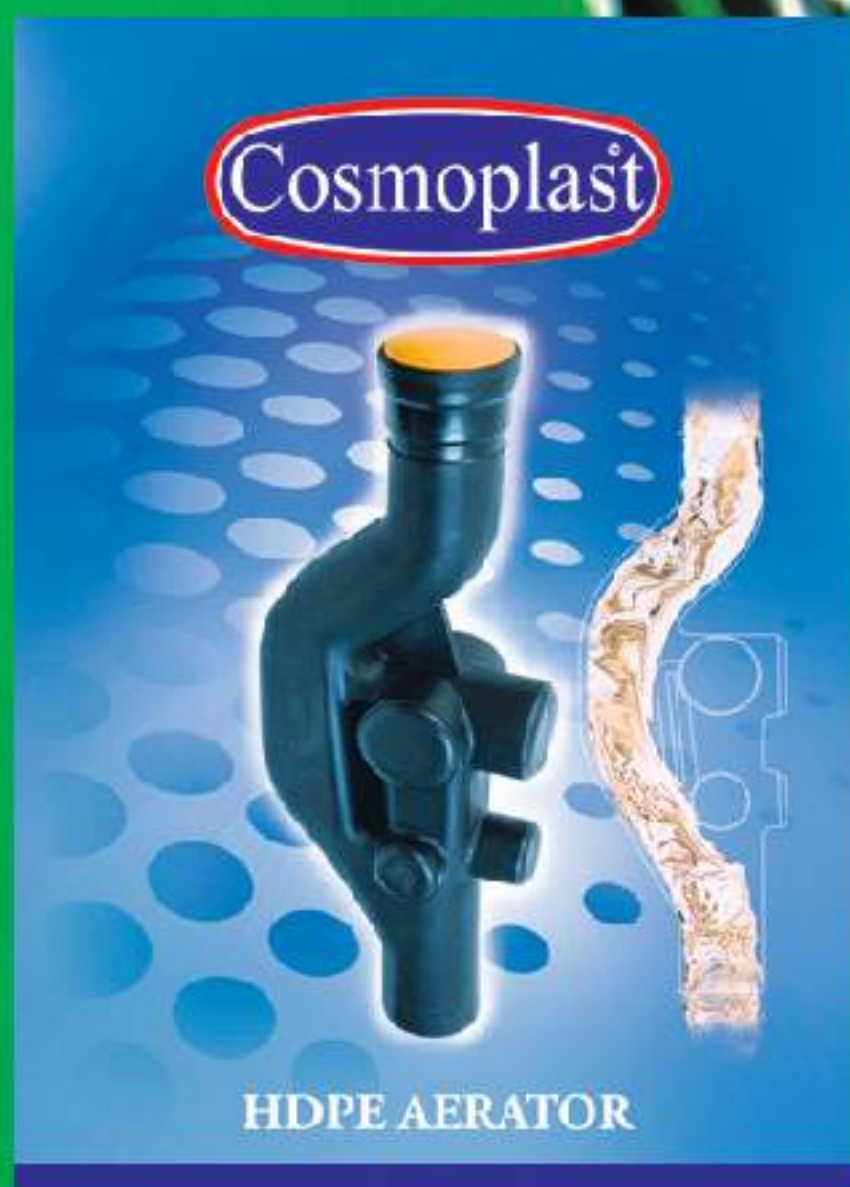
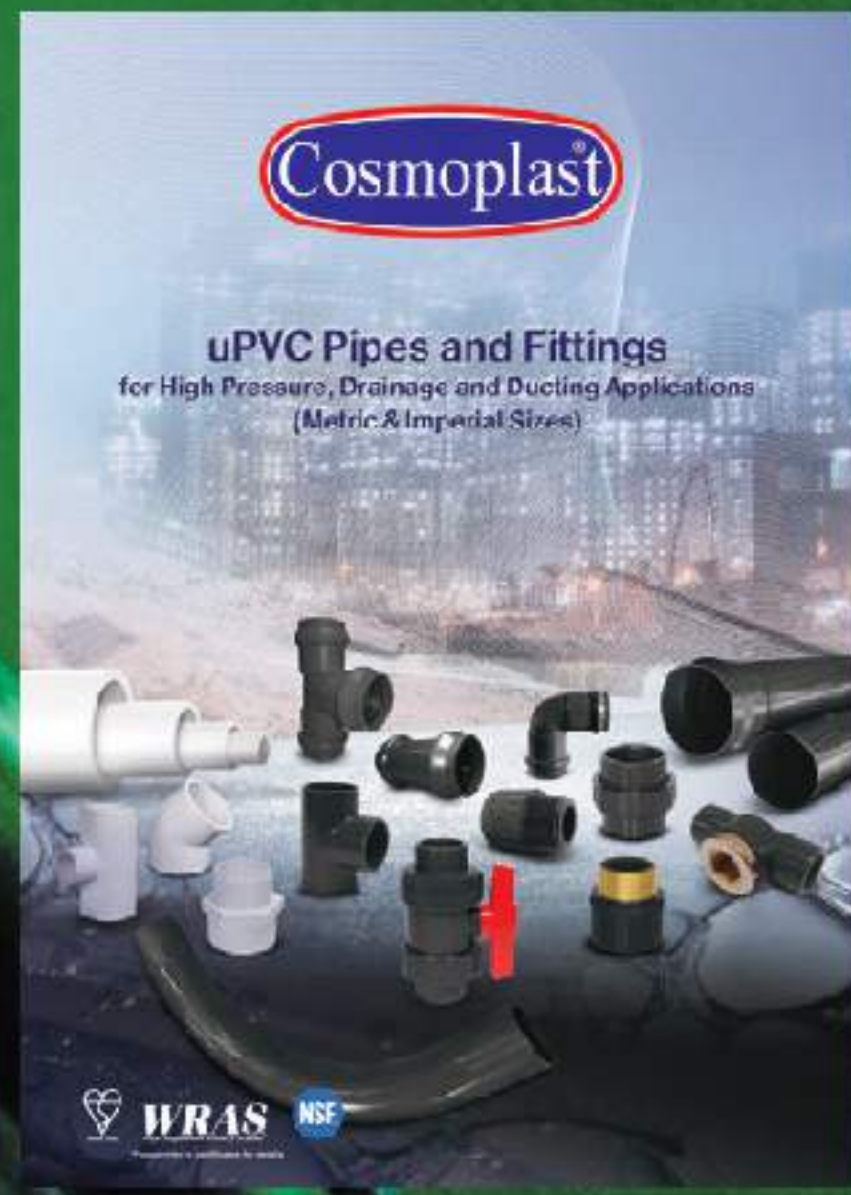
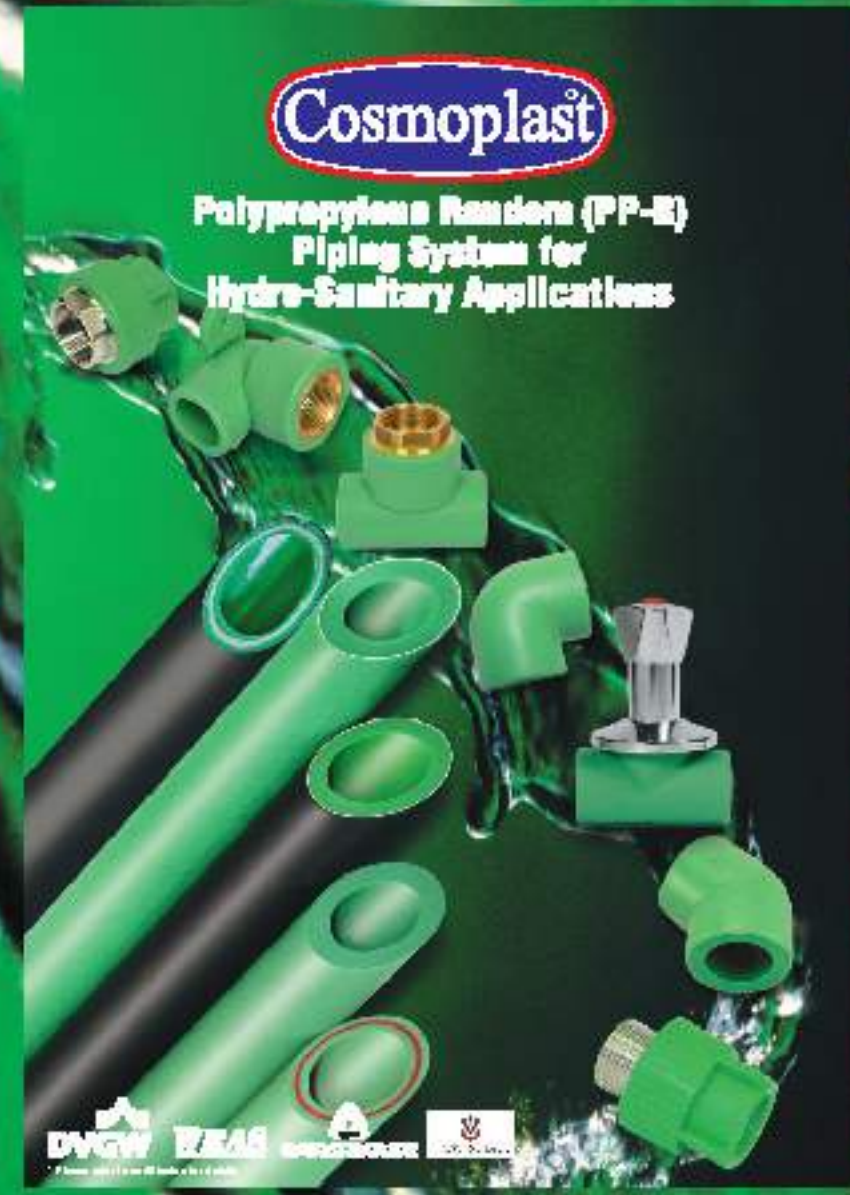
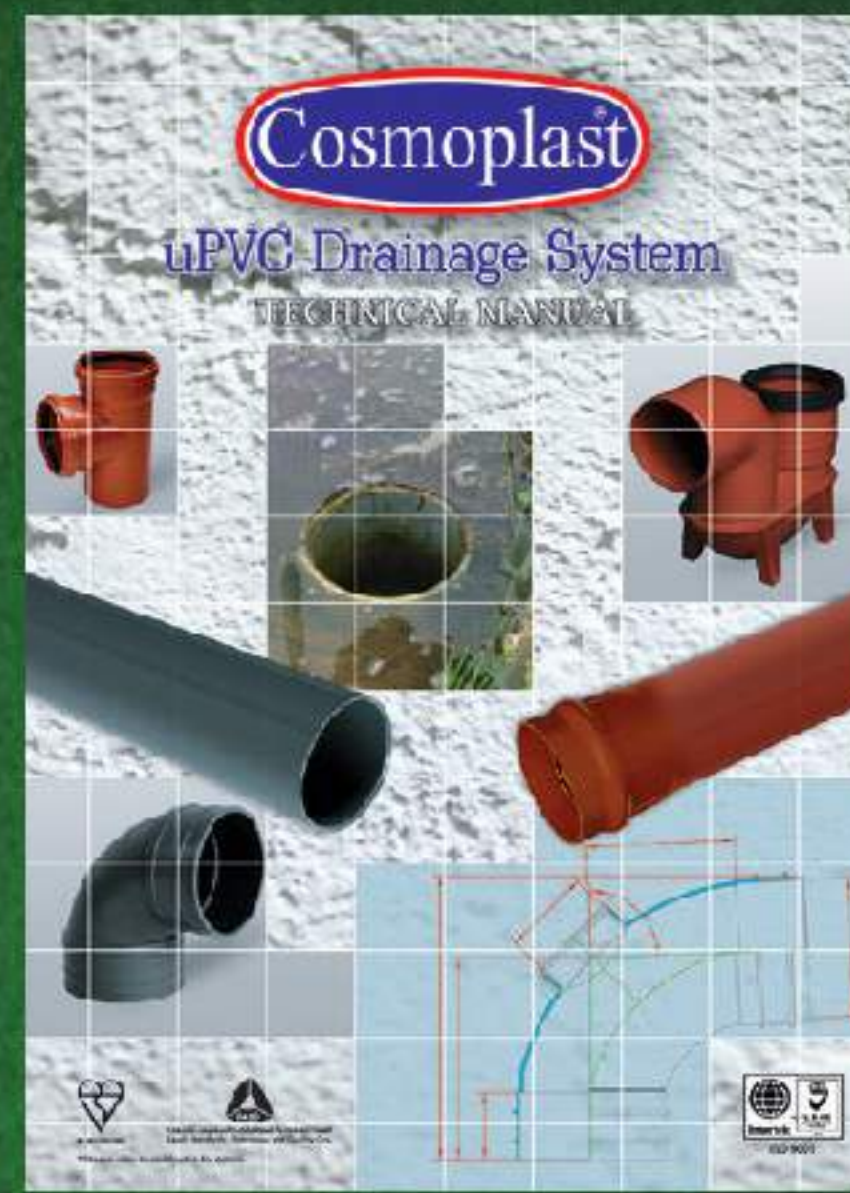
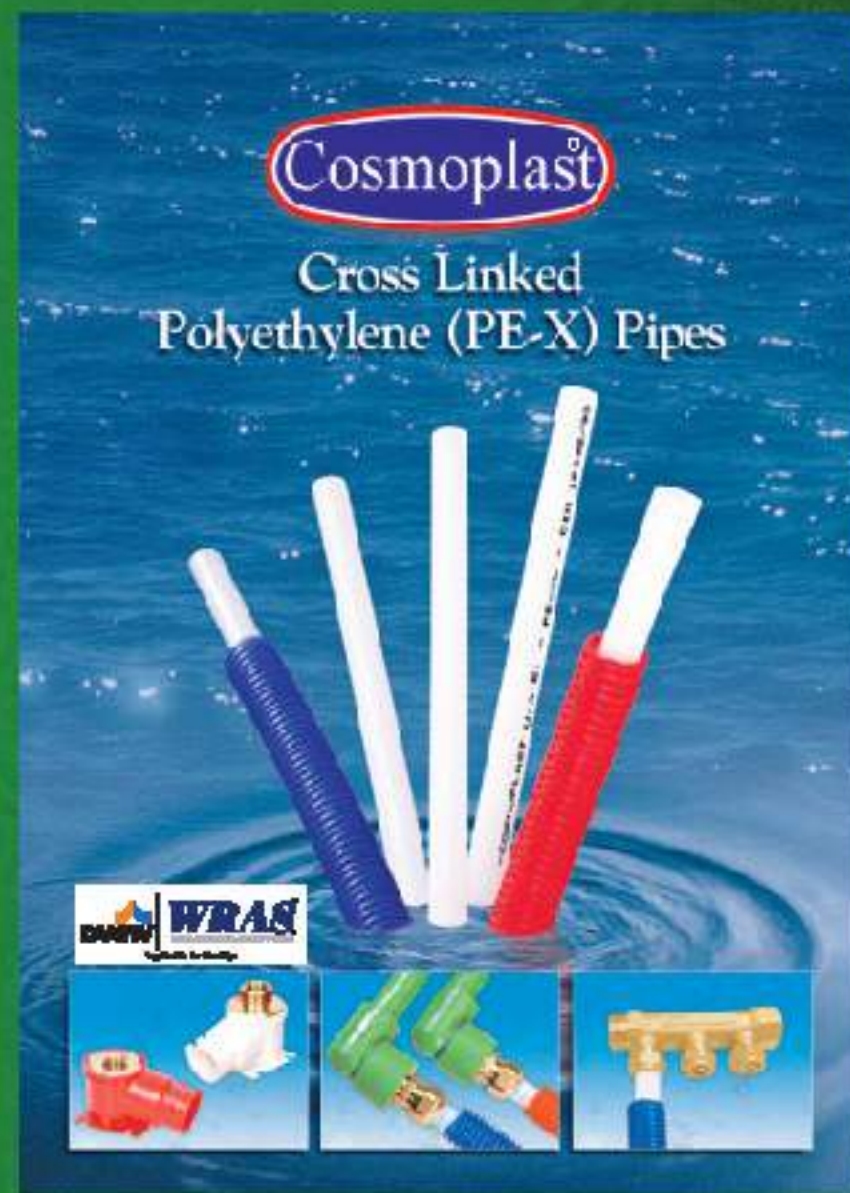

www.cosmoplast.com

Cosmoplast Industrial Co. LLC

Sharjah

Sales Off. Tel: +971 6 5331212
 Fax: +971 6 5331917 / 5332901
 P.O. Box: 6032

Dubai

Tel: +971 4 8850500
 Fax: +971 4 8850700
 P.O. Box: 50488

Abu Dhabi

Sales Off. Tel: +971 2 5515364
 Fax: +971 2 5515365
 P.O. Box: 8593

Saudi Arabia-Riyadh

Tel: +966 11 265 4501
 Fax: +966 11 471 4669
 Email: pipeline@interplast-ksa.com

Qatar-Doha

Tel.: +974 44687881/2
 Fax: +974 44687886
 Email: info@harwalqa.com

Email: pipe@cosmoplast.com

