

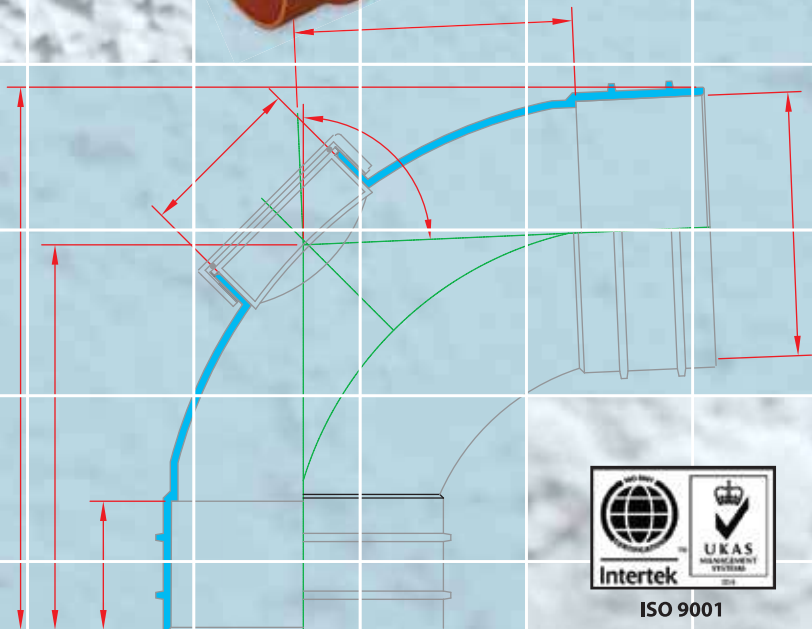

uPVC Drainage System

TECHNICAL MANUAL

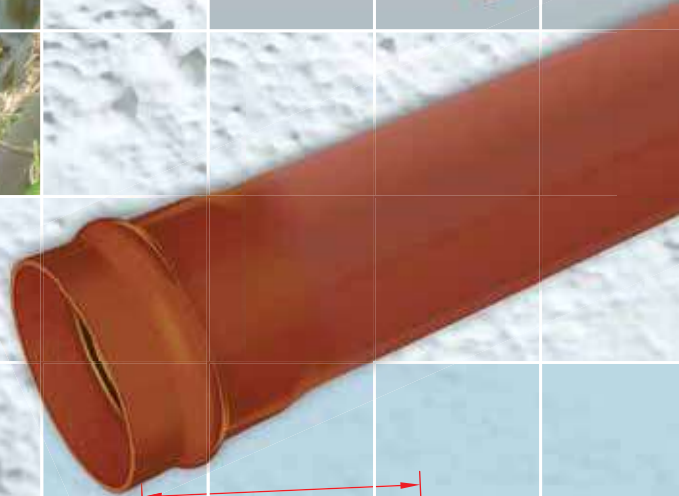

BS EN 1329/1401



الهيئة السعودية للمواصفات والمقاييس والجودة
Saudi Standards, Metrology and Quality Org.

* Please refer to certificates for details



ISO 9001

Since it was established in 1976 Cosmoplast has become the market leading manufacturer of plastic piping systems in the Middle East. Through extensive product development, long term planning and substantial capital investment, Cosmoplast offers one of the most comprehensive and highest quality range of uPVC pipes and fittings for drainage applications.

Today the company has a turnover of more than \$ 100 million and supplies its products not only to the Gulf region but also throughout the Middle East, and specifically designed product ranges into Europe, Africa and the Far East.

Cosmoplast drainage systems include an extensive range of soil and waste pipes and fittings for commercial, industrial, housing and public sector developments.

Cosmoplast drainage systems include both solvent welded and push fit types applicable for wide and comprehensive range of

pipes and accessories. Having been pioneers in the development of drainage systems, Cosmoplast drainage systems represent the benchmark for quality product innovation and outstanding services.

Complete Solutions

With the wide range of pipes and fittings covering the size range from 36mm up to 630mm, Cosmoplast now offers the most complete choice for its customers. The product range covers all the items required to complete any domestic and industrial drainage system.

Cosmoplast soil and waste drainage system is fully compatible with its above the ground and underground systems. This enables integrated above and below ground drainage systems to be designed, specified, and supplied from a single reliable source with confidence.



Advantages of Cosmoplast uPVC Drainage System

Advantages of Cosmoplast uPVC Drainage System:

All products supplied by Cosmoplast come with additional advantages like

- Proven research to suit customer's application needs.
- Precise manufacturing according to International Standards.
- ISO 9001 Quality System Accredited Manufacturing environment.
- Stringent testing to international standards.
- Technical service and consulting back up.
- Installation and jointing advice and services.
- Assured timely deliveries.
- Maintenance-free system and long-term reliability.



KITE MARKED PIPES AND FITTINGS QUALITY ASSURED PRODUCTS

Cosmoplast drainage systems are manufactured according to the latest European Standards, and are subject to very strict Quality Policy supervised by BSI which enabled Cosmoplast systems to be approved by the most prestigious International Institutes.

Cosmoplast Underground and Above Ground Drainage Pipes & Fittings are approved by the British BSI and are awarded the Kite Mark Quality Certificate where applicable.



BS 5255



BSEN 1329-1



BSEN 1401-1



NEW EUROPEAN STANDARDS (EN STANDARDS)

COSMOPLAST uPVC drainage pipes and fittings are manufactured and tested in accordance with the new British - European Standards BS EN which have replaced the old British Standards for drainage applications. The new BS EN standards cover all the sizes and applications of the BS Standards.

BS EN 1329-1

applies to uPVC piping systems for soil and waste discharge (low and high temperature) within the building structure. This standard replaces the British Standards BS5255 and BS4514. Products made to BS EN1329 are fully compatible with the products made to BS5255 and BS4514.

BS EN1401-1

applies to uPVC piping systems for underground drainage and sewerage. This standard has replaced most of BS4660 and all of BS5481. Products made to BS EN1401-1 are fully compatible dimensionally with the products manufactured to BS 4660 and BS 5481.



BS EN 1329/1401



ISO 9001

Jointing Techniques

SOLVENT CEMENT JOINTING

To achieve effective reliable joints:

1. Cut the pipe at right angle using appropriate cutter or saw.

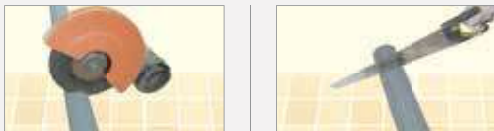

2. Chamfer the pipe and remove the burrs and filings.



3. Clean the spigot and socket with a dry cloth. It is recommended to roughen the mating surface using emery paper and apply the cleaner to internal surface of the fitting and external surface of the pipe



4. Apply a thin layer of solvent cement first to inner surface of the socket and then on the spigot to the mating surfaces using suitable brush.



5. While the solvent cement is still wet, insert the pipe inside the fitting until it reaches the socket end. It is recommended to twist the pipe a 1/4 turn while inserting it inside the fitting for better distribution of the cement.



6. Wipe the excess cement and leave the joint to dry.



Note :

Applying excessive quantity of solvent cement should be avoided as it creates pool of cement on the internal surface of the pipe that will continue to corrode the surface and weaken the pipe and fitting and might cause the joint to fail at high pressure.

PUSH FIT JOINTING

1. Cut the pipe at right angle using appropriate cutter or saw.



2. Chamfer the pipe and remove the burrs and filings.

3. Clean the pipe and fitting with dry cloth



4. Apply a thin layer of appropriate lubricant on the rubber ring using a suitable brush.



5. Insert the pipe inside the fitting until it reaches the socket end, then withdraw the pipe 5 – 10mm (depending on the size) to allow for expansion / contraction.



6. Wipe the excess lubricant..



CUTTING THE PIPES

While cutting Cosmoplast uPVC pipes, the following instructions should be followed:

- Appropriate pipe cutter or saw should be used.
- Cut the pipes square and perpendicular to its axis.
- After cutting the pipes, remove all burrs from the cut end, and bevel the sharp cutting edge.





SOLVENT WELDING IN HOT WEATHER CONDITIONS :

During hot weather conditions of 35°C and above, special consideration should be given to the process of solvent Welding of UPVC pipes and fittings to ensure a leak proof joint.

Solvent cements contain high strength chemical solvent which evaporates faster at elevated temperatures and in windy conditions.

When PVC pipes are stored in open areas or under direct sunlight, the pipe surface temperature will be around 15°C higher than the ambient temperature. The solvent cement attacks the hot surface faster and deeper. Therefore, it is very important to avoid using excess cement during the jointing process to avoid creating pools of cement inside the fitting and pipe sockets. Excess solvent cement should be wiped off the joined surface quickly.

Recommendations for the solvent welding during hot weather conditions:

1. Solvent cement and cleaners should be stored in a cool or shady area .
2. Pipes and Fittings should be stored in a shady area before solvent welding
3. The surfaces to be joined should be cooled by wiping with a wet cloth. The surfaces should be dry before applying the solvent cement.
4. Solvent welding is recommended to be done during the morning hours.
5. The two surfaces should be joined quickly while they are still wet with cement.
6. Shake or stir the solvent cement well before use.
7. Allow at least 24 hours for the joints to cure before pressurizing the system. For sizes above 8” at least 48 hours should be allowed.



BS EN 1329/1401



ISO 9001

SUPPORT AND EXPANSION

- All pipework must be adequately supported whether vertical or horizontal.
- Plastic pipework expands and contracts with changes in temperature - whether ambient temperature or from the nature of the discharge through the pipework. Expansion joints must therefore be provided to accommodate such thermal movement.
- Horizontal pipework requires more frequent support than vertical pipework (for example, soil stacks)
- Suitable sound absorbing brackets with rubber lining should be used to support pipes. Those brackets must be dimensionally compatible to the pipe diameter. A fixed bracket creates a fixed point in the pipe system.
- With fixed brackets the pipe or fitting can not be moved through the bracket after screws are tightened. In order to prevent sliding down of vertical pipes, each individual pipe must be secured on one point by a fixed bracket.
- Every horizontally installed pipe should always be fixed with one fixed bracket. All remaining pipe brackets in horizontal as well as in vertical installation must be tightened in such a way to allow sliding.
- Fixed brackets must be installed directly above the fitting at the bottom of the pipe end. The sliding bracket must be installed at a distance of maximum of two meters above the fixed bracket.
- Pipe brackets should be fixed on building materials with high strength in order to assure strong and durable pipe fixing.
- It is recommended that only steel brackets (ie. not plastic brackets) be used on interior soil stacks which are subjected to fire regulations.
- Any point where pipework passes through a floor or wall and is made as a fire stop, it must be treated as a fixed point for the purposes of determining positions of expansion joints.



SUPPORT DISTANCES

	Maximum Support Distance	
	Vertical	Horizontal
Pipe Size - Soil		
82 mm	2 m	1 m
110 mm	2 m	1 m
160 mm	2 m	1.2 m
Pipe Size - Waste		
32 mm	1.2 m	0.5 m
40 mm	1.2 m	0.5 m
50 mm	1.2 m	0.5 m

EXPANSION IN uPVC PIPES

The PVC piping systems expand and contract with changes in temperature, both from ambient temperature and from the temperature of the fluid passing through the pipework.

The following sections explain the techniques of estimating and treating the expansion in PVC pipes.

Calculation of Expansion

The co-efficient of linear expansion of PVC pipes is relatively small compared to other plastic materials. However, the effects of thermal expansion in the system should be compensated wherever necessary.

The thermal expansion in PVC straight sections can be calculated using the below formula:

$$\Delta L = \alpha \times L \times \Delta T$$

Where:

ΔL = expansion (mm)

α = co-efficient of linear expansion (mm/m/°C) = 0.08

L = length of the pipe (m)

ΔT = temperature difference (°C)

between the hottest month of the year and the month during which the installation is to be carried out.

Support and Expansion Distances

In general, rubber ring pipework (Push Fit) do not require expansion joints, as the rubber sockets in the fittings and pipes act as expansion joints to absorb the expansion and contraction.

Whereas, in solvent welding pipework, the expansion should be calculated and compensated as described below.

After calculating the thermal expansion in the PVC pipes, expansion couplers (Rubber ring couplers) should be installed in proper locations to absorb the change in pipe length.

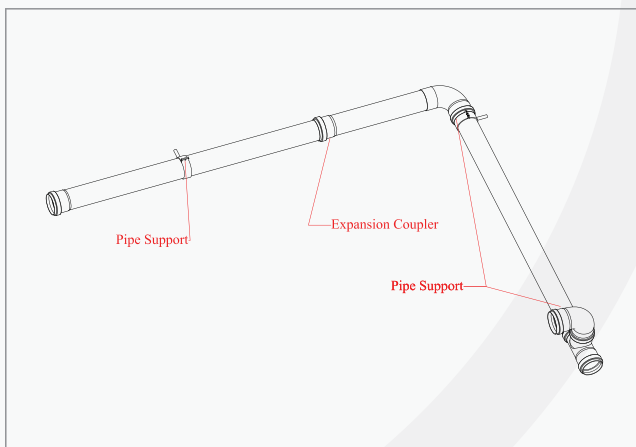
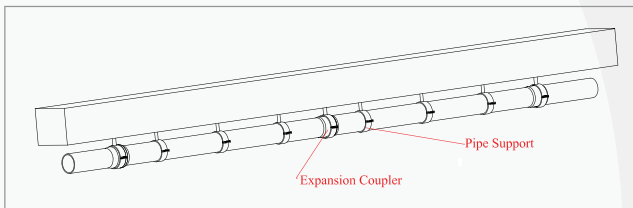

Support & expansion distance

Pipe work should be provided with expansion couplers installed at appropriate locations with in the piping network.

VERTICAL INSTALLATIONS

Vertical Installations can be done in two ways:

a) Fixed Installation

b) Free Installation

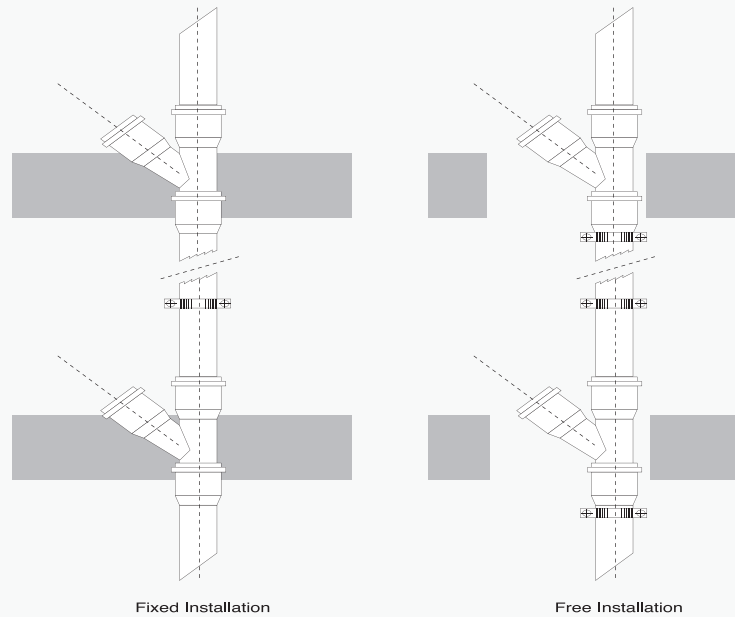

HORIZONTAL INSTALLATIONS

In horizontal Installations, pipe clamps should be placed at intervals which are approximately ten times bigger than the pipe diameter. This will ensure that the installation is fixed and will not bend.

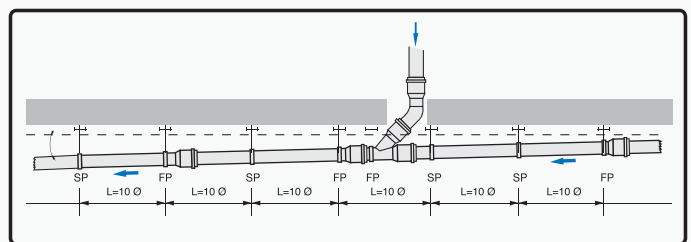

FP= Fixed point

SP= Sliding point

\varnothing = Pipe Diameter

VENTILATION

Ventilation is essential in every drainage system. In order to prevent traps being emptied by suction or pressure, both overpressure and underpressure should not exceed 300 Pa (30 mm water column). Air should be able to escape from the system (venting) and to enter the system (admittance). A ventilated discharge pipe is used for this purpose.

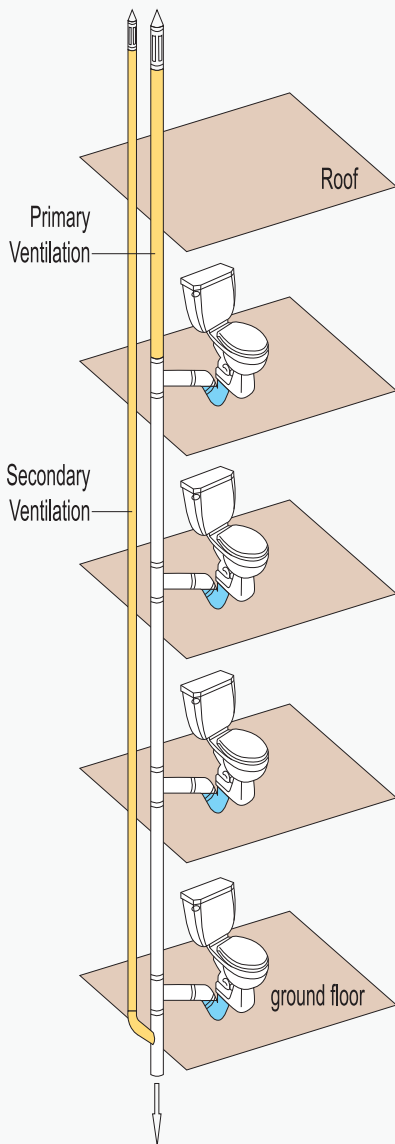

Technique (1)

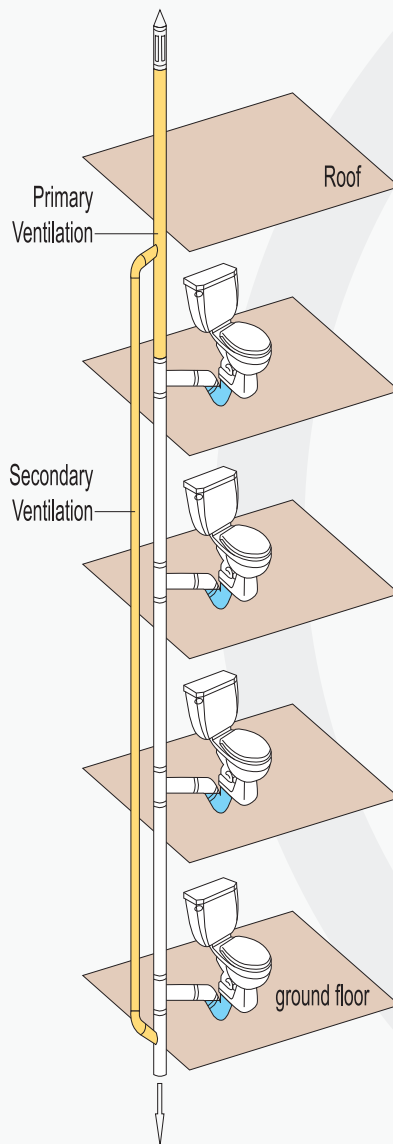

Technique (2)

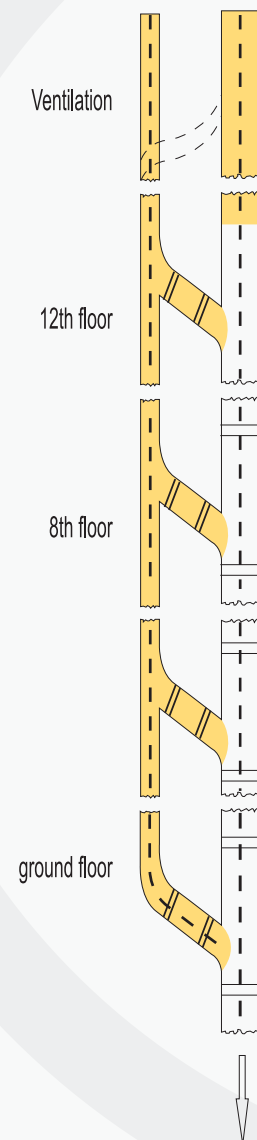

Technique (3)

CROSS-FLOW PREVENTION

When connecting small waste pipes to vertical discharge stacks, attention should be given to avoid the cross-flow from one branch to the other. The restricted entry zone (L) for the opposite waste pipe varies depending on the stack diameter, within which no connections should be made. However, connections are allowed at right angles of the boundary center line or directly opposite.

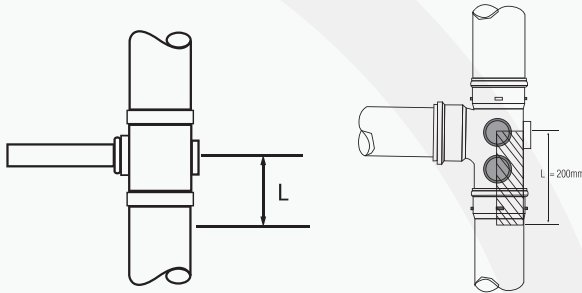

Stack Dia.	L (mm)
82	90
110	110
160	250

In case of cross flow from a large diameter to a small waste pipe, the cross flow should be prevented by connecting the waste pipe at or above the center line of larger branch. Connections are not allowed at right angles of boundary center line or directly opposite. In this case the restricted entry zone is always 200mm regardless of stack diameter.

RAINWATER OUTLETS (ROOF DRAINS)

Cosmoplast product range includes different models and options of rainwater outlets like the dome type, corner type, flat type...etc. they are all suitable for roofs with and without waterproofing systems.

All Cosmoplast roof drains are connected to the rainwater pipes without traps.



The corner type rainwater outlet enables both side and bottom connections to the rainwater pipes.

The gratings of all Cosmoplast rainwater outlets are connected to the uPVC body by screws which allow easy access to the rainwater pipes in case of maintenance or cleaning.

ACCESS FITTINGS

Access fittings should be installed at proper accessible locations in the system to enable cleaning and discharging any blockage that may occur in the system due to solid deposits.

These access fittings enable the insertion of cleaning hoses and springs whenever blockage occurs.

Access pipes are recommended to be installed on stack pipes at every 3 to 4 storeys to enable multiple access points to the stack and allow the whole stack to be cleaned if needed.



Access fittings are also recommended to be installed at the points of connection between underground and above ground pipework, after pipework sections that include multiple bends and long pipe runs and on pipeworks which are casted in concrete.

TESTING DRAINAGE SYSTEMS

Drainage installations should be tested for leaks and defects in new installations and whenever the existing installation is altered, extended or repaired.

All new installations or modified portions should be left uncovered until the testing is successfully completed and approved.

Drainage systems are commonly tested by water and in some cases air test is done.

The following are some guidelines for testing drainage systems, while the local codes of practice for each country should also be noted and applied.

WATER TEST

- All pipe ends and connections must be plugged using suitable testing plugs.
- Install vertical pipe length to the drain to provide the necessary testing water head.
- Fill the system with water to maximum height of 3m (30 kPa).
- The maximum head at the lower parts of the system should never exceed 4.0m, therefore in case of steep gradients the system should be tested in sections.
- The filled system should be left 2 hours under testing, during which the system should be inspected by measuring the drop in water height.
- The pipe work should be inspected for any leakage and all defected installations should be repaired and tested again.



- Provide side support with 75mm wide battens at 1m centers.
- Maximum stack (normal conditions): seven layers high.
- Ideally, stacks should contain one diameter pipe size only. Where this is not possible, stack largest diameter pipes at base of stack. Small pipes may be nested inside larger pipes.
- If stored in the open for long periods or exposed to strong sunlight, cover the stack with opaque sheeting.
- Store fittings under cover. Do not remove from cartons or packaging until required.
- Store solvent cement and cleaning fluid in a cool place out of direct sunlight and away from any heat source.

Storage in hot climates

- Ultra-violet light can affect pipes and fittings: pipe colour may change and rubber seals may be degraded
- Accordingly:
 - » store all materials in well-ventilated, shady conditions
 - » do not expose to direct sunlight
 - » keep fittings in original packaging until required for use
- Maximum stack (hot conditions) six layers high .

Transport

While transport, pipes should be arranged safely on trucks avoiding crossing, bending and over stacking.

The pipes should also be fully supported over their total length.

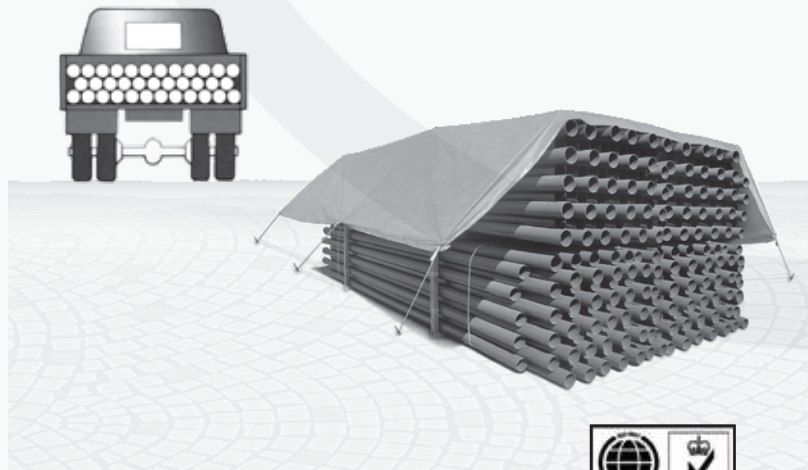

GOOD SITE PRACTICE

Handling

- Take all reasonable care when handling uPVC, particularly in very cold conditions when the impact strength of the material is reduced.
- Do not throw or drop pipes, or drag them along hard surfaces.
- In case of mechanical handling, use protective slings and padded supports. Metal chains and hooks should not make direct contact with the pipe.

On-site Storage

- Stack pipe lengths:
 - » either on a flat base
 - » or on a level ground
 - » or on 75mm x 75mm timber at 1m max. centers.

RECOMMENDATIONS

a) The pipe must be cut with a fine saw. Big saw teeth would damage the pipes. The cut has to be vertical.

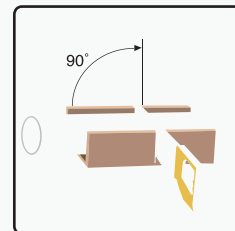

b) The pipe ends should be smoothly chamfered to an angle of 15° to ensure better jointing and avoid damaging the rubber ring.

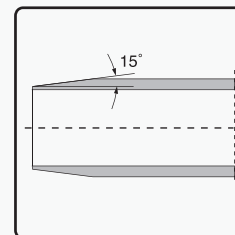
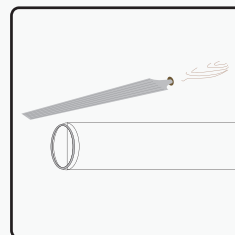

c) It is not recommended to shorten the fittings as it could result in defective joints.

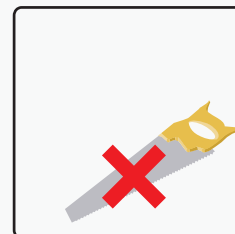

d) Connected pipes and fittings need to be fitted straight. Otherwise it could result in leakage at sealing points.

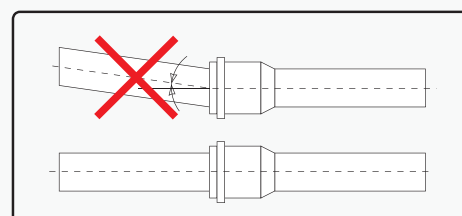

e) Before covering the pipes with concrete, it is recommended to cover the joints so that cement doesn't enter the joints.

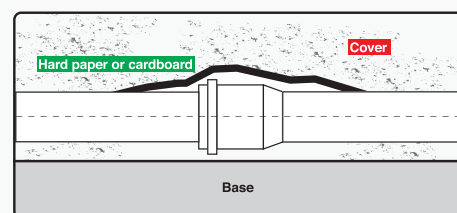
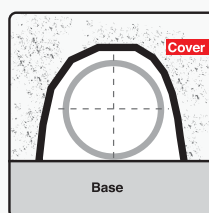

f) Pipes must be correctly connected considering the expansion. Too shallow connections into the cap do not guarantee a safe joint, while too deep connections do not allow expansion.

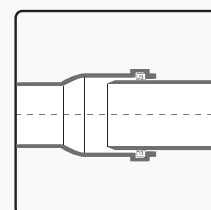
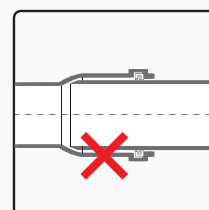
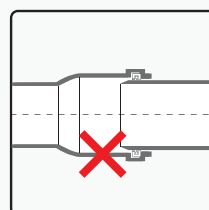

MATERIAL PROPERTIES

The following table shows the main physical and thermal properties of the uPVC material:

Property	Value	Units
Physical properties		
Density	≥ 1.42	g/cc
Water absorption	≤ 4	mg/cm ²
Impact strength (23°C)	7	KJ/m ²
Hardness	80	Shore D
Mechanical properties		
Tensile strength	≥ 45	N/mm ²
Elongation	≥ 80	%
Elastic Tensile Modulus	≥ 2700	MPa
Thermal properties		
Vicat Softening point	≥ 79	°C
Coefficient of Linear thermal expansion	0.08	mm/m°C
Thermal conductivity	0.16	W/(m.K)
Others		
Flammability	V-0	UL-94
Poisson's ratio	0.4	-
Hazen-Williams factor C	150	-

1 - Corrosion resistance:

uPVC being a non-conductor is totally resistant to all types of galvanic and electromechanical influences which might corrode it. Being non-metallic, uPVC is resistant to any type of corrosion caused by water as well as a large range of industrial liquids and chemicals. Seepage from high sulphate soils as well as low hardness waters also do not threaten it. This in turn translates into a longer installed life of the uPVC pipe systems.

2 - Resistance to Abrasion:

uPVC pipes are highly resistant to abrasion due to stress from abrasion fluids of excessive pressure. Tests have shown that uPVC pipes are up to 2.5 times more resistant to abrasions when compared to steel.



3 - Resistance to biological attack and growth:

uPVC is completely resistant to any microscopic life that it might be exposed to. It does not offer a nourishing source to any bacterial life form and is completely guaranteed to withstand any such growth.

4 - Reaction with Building Materials:

uPVC does not react with any of the normal building materials like cements and paints. However, information about the chemical resistance of uPVC to a wide range of chemicals can be found in the tables of Chemicals Resistance listed in this catalogue.

5 - Thermal Expansion

The coefficient of linear expansion for uPVC is 0.08 mm/m/°K which means less than 1mm per each 1m length in case of a temperature rise of 10°C.

The thermal expansion in drainage systems should be treated by using push fit (rubber rings) fittings and sockets which should be located in suitable locations (BSEN 12056 - Code of Practice for Sanitary Pipework).

6 - Effect of sunlight:

Long exposure to sunlight causes the colour of uPVC to fade, in addition to the reduction of impact strength. The effect of sunlight does not seriously affect the performance of the system, however it is always advisable to protect the system from the direct exposure to sunlight by painting the exposed parts with any exterior gloss paint (paint specialists can recommend the suitable types).

7 - Effect of frost:

The uPVC is not affected by frost, however sub-zero temperatures reduce the impact strength of the uPVC system. Therefore, extra care is to be given while handling and installing uPVC during sub-zero temperatures.

8 - Fire Hazard & Flammability of UPVC Pipes:

uPVC pipes and fittings should be stored in dry and covered places and protected from direct sources of heat and sunlight. It should be noted that the packing cartons and pallets can form a fire risk and may participate in fire spread.

uPVC is self-extinguishing material as per BS2782 and fire rated as Class 1 as per BS476 - Part 7 and Class 0 to Part 6.

Due to its flame retardant property, uPVC finished products do not participate in fire. uPVC products have a higher ignition temperature than most of the other thermoplastic and organic materials.

When it burns, uPVC forms a protective char layer, which in turn act as an insulation layer that stops oxygen.

9 - Fire Fighting:

All common fire extinguishers can be used effectively for fighting fires involving PVC.

Chemical Resistance of uPVC

The uPVC material has a high resistance to a wide range of chemicals which makes the uPVC as an ideal option for many residential and industrial applications.

Detailed tables for the chemical resistance of uPVC material can be provided upon request.



BS EN 1329/1401



ISO 9001



uPVC Soil, Waste and Above Ground Discharge System

Cosmoplast soil, waste and above ground drainage pipes and fittings are manufactured according to the latest European Standard BS EN 1329-1 from grey unplasticised polyvinyl chloride uPVC in sizes 36 mm to 315 mm.

Size 36 mm to 56 mm according to BS 5255 are manufactured from mUPVC or ABS.

Cosmoplast soil, waste and above ground drainage systems are available in two options:

1. Solvent Welding Type: with sizes from 36 mm up to 200 mm.
2. Rubber Ring (Push Fit) Type: with sizes from 40 mm up to 315 mm.

Both options are suitable for domestic drainage and particular requirements of commercial, industrial and public installations. BSEN 1329 - 1 uPVC Drainage Pipes for Above Ground Drainage

Normal Size (mm)	Application Area					
	O.D. (mm)		B		BD	
	min	max	Wall Thickness (mm)		Wall Thickness (mm)	
			min	max	min	max
* 32	32.00	32.20	3.00	3.50	-	-
36	36.20	36.50	3.00	3.50	-	-
40	40.00	40.20	3.00	3.50	-	-
43	42.80	43.10	3.00	3.50	-	-
50	50.00	50.20	3.00	3.50	-	-
56	55.80	56.10	3.00	3.50	-	-
75	75.00	75.30	3.00	3.50	3.00	3.50
82	82.00	82.30	3.00	3.50	3.00	3.50
110	110.00	110.30	3.20	3.80	3.20	3.80
160	160.00	160.40	3.20	3.80	4.00	4.60
200	200.00	200.50	3.90	4.50	4.90	5.60
250	250.00	250.50	4.90	5.60	6.20	7.10
* 315	315.00	315.60	6.20	7.10	7.70	8.70

* Produced upon request only.

BS 5255 - mUPVC and ABS Waste Pipes

Normal Size (mm)	W.T. (mm)	O.D. (mm)		Wall Thickness (mm)	
		min	max	min	max
1¼" / 36mm	1.80	36.15	36.45	1.80	2.20
1½" / 43mm	1.90	42.75	43.05	1.90	2.30
2" / 56mm	2.00	55.75	56.05	2.00	2.40

DIN19531 - 10; uPVC Pipes for Drainage Systems Inside Buildings

Normal Size (mm)	W.T. (mm)	O.D. (mm)		Wall Thickness (mm)	
		min	max	min	max
50 mm	1.80	50.00	50.20	1.80	2.20
75 mm	1.80	75.00	75.30	1.80	2.20



BS EN 1329/1401



ISO 9001

Solvent Welding Joints

uPVC Drainage Pipe

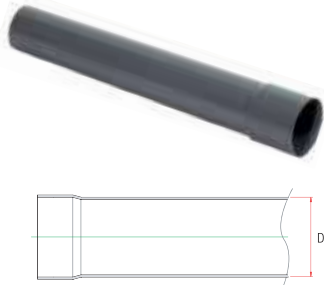

Nominal O.D. (mm)	Length (m)
* 36	4
40	4
* 43	4
50	5.8 / 6
* 56	4
75	5.8 / 6
82	5.8 / 6
110	5.8 / 6
160	5.8 / 6
200	5.8 / 6

Straight Coupler

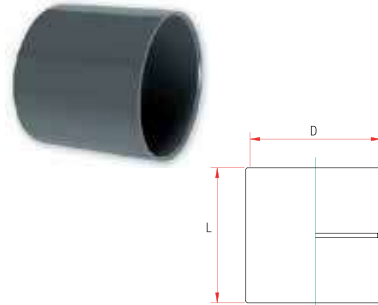

D (mm)	L (mm)
* 36	45
* 43	45
50	52
* 56	56
75	83
82	96
110	112
160	161
200	140

87.5° Elbow

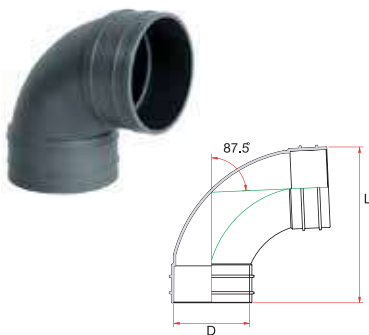

D (mm)	L (mm)
* 36	77
* 43	90
50	101
* 56	100
75	137
82	170
110	190
160	329
200	305

45° Elbow

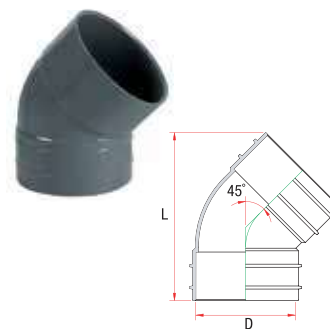

D (mm)	L (mm)
* 36	67
* 43	83
50	86
* 56	94
75	128
82	139
110	170
160	269
200	290

45° Y Branch

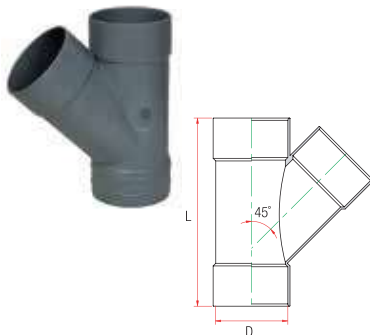

D (mm)	L (mm)
* 36	102
* 43	115
50	125
* 56	144
75	192
82	205
110	268
160	337
200	400

45° Reducer Y Branch

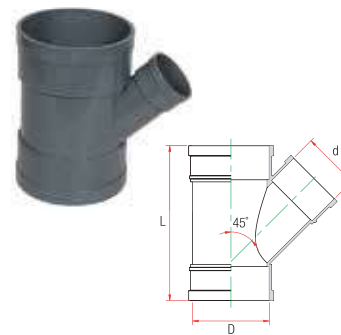

D (mm)	d (mm)	L (mm)
75	50	156
82	56	179
110	50	175
110	56	187
110	75	209
110	82	224
160	110	283
200	160	400

87.5° Tee Branch

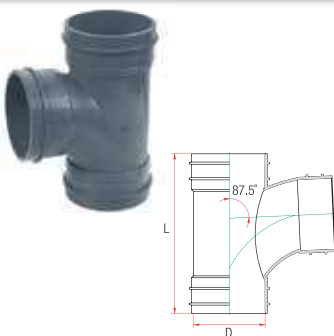

D (mm)	L (mm)
* 36	90
* 43	109
50	106
* 56	132
75	167
82	176
110	250
160	358
200	365

87.5° Reduced Tee

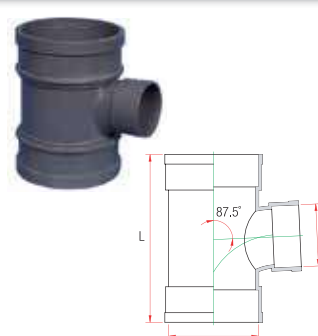

D (mm)	d (mm)	L (mm)
75	50	143
82	56	162
110	50	156
110	56	167
110	75	187
110	82	201
160	110	250
200	160	360

* Available in UPVC and ABS

Reducer Bush

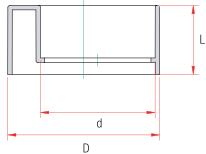

D (mm)	d (mm)	L (mm)
43	36	21.3
56	36	27.7
56	43	28.2
75	50	42
82	43	37.6
82	56	37.3
110	50	56
110	56	50
110	75	56
110	82	50
160	110	74.7
200	160	92.2

45° Access Elbow

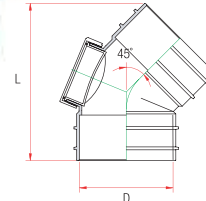

D (mm)	L (mm)
56	94
82	139
110	170

87.5° Access Elbow

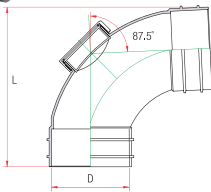

D (mm)	L (mm)
43	93
50	94
56	100
75	133
82	170
110	190
160	329

87.5° Access Tee

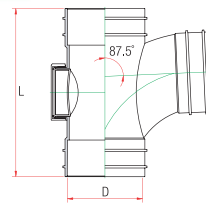

D (mm)	L (mm)
43	109
56	132
82	205
110	250
160	358

Access Pipe

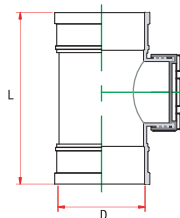

D (mm)	L (mm)
50	102
75	160
82	212
110	219
160	256

Access Plug

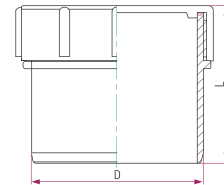

D (mm)	L (mm)
40	75
* 43	50
50	75
* 56	50
75	89
82	77
110	88
160	95
200	100

Pipe Access Plug

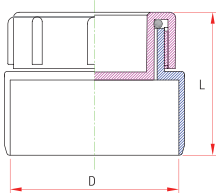

D (mm)	L (mm)
36	47
43	52
56	55
75	69
82	75
110	80
160	95

Double Tee with Access



D (mm)	d (mm)	L (mm)
110	110	219

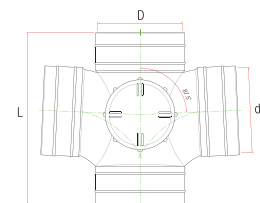

uPVC Deep Seal Floor Trap



D (mm)	d (mm)	d1 (mm)	H (mm)
110	82	56	175
110	82	43	175

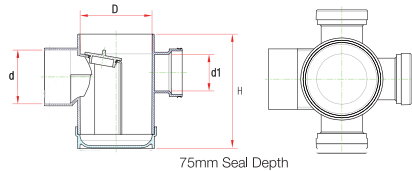

75mm Seal Depth

uPVC Floor Trap with Removable Separator



D (mm)	d (mm)	d1 (mm)	H (mm)
110	82	43	170

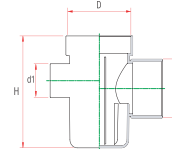

Body Material can be:
- UPVC
- ABS

70 mm seal depth

ABS Deep Seal Floor Trap



D (mm)	d (mm)	d1 (mm)	H (mm)
110	82	56	175

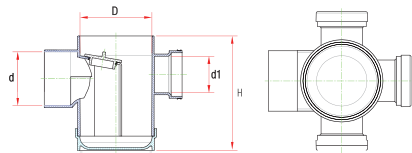

75mm Seal Depth

Metric Floor Trap



D (mm)	d1 (mm)	d2 (mm)	H (mm)	H1 (mm)
110	75	50	162	56.5

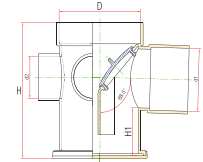

Body Material can be:
- UPVC
- ABS

70mm Seal dept

Short Floor Trap



D1 (mm)	d2 (mm)	d3 (mm)	H (mm)
110	82	43	108
110	82	56	108

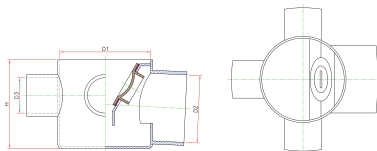

40mm Seal Depth

uPVC Floor Trap 160 mm



D1 (mm)	d2 (mm)	d3 (mm)	H (mm)
160	110	50	160
160	110	56	160

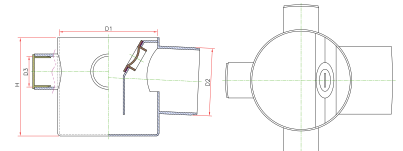

70mm Seal Depth

Boss Pipe MXF



D (mm)	d1 (mm)	d2 (mm)	L (mm)
110	56	43	209

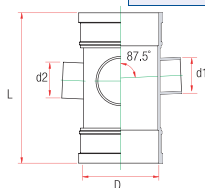

Boss Pipe FXF



D (mm)	d1 (mm)	d2 (mm)	L (mm)
110	56	43	209

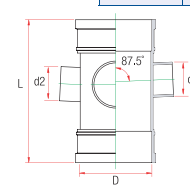

Boss Connector



Ø	D (mm)	L (mm)
160	56	43
160	43	36
110	56	50
110	43	40

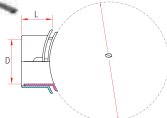

AC to Drainage Boss



D (mm)	d	L (mm)	F (mm)
43	1"	41	52

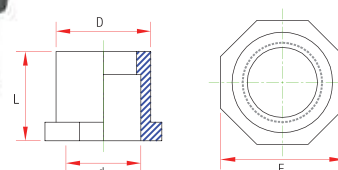

AC to Drainage Boss



D (mm)	d1	d2	L (mm)
56	1"	3/4"	34

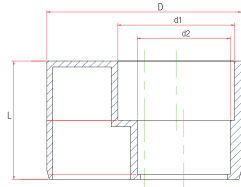

45° Double Y Branch



D (mm)	d (mm)	L (mm)
50	50	128
75	75	193
110	110	260

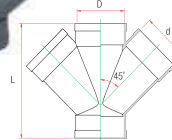

87.5° Double Tee Branch



D (mm)	d (mm)	L (mm)
50	50	106
75	75	166
110	110	219
160	160	219

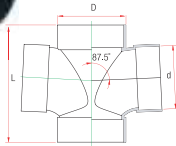

Flat Roof Drain



d (mm)	D (mm)	L (mm)
82	178	40

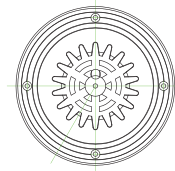
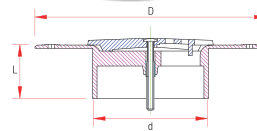

Vent Cowl

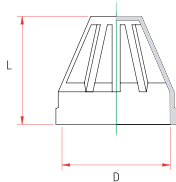

D (mm)	L (mm)
50	63
56	70
75	84
82	85
110	105
160	138

Rainwater Outlet



d (mm)	D (mm)	L (mm)
82	180	115
110	343	117

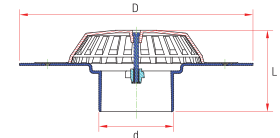
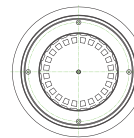

Dome Type Rainwater Outlet (HD)



d (mm)	D (mm)	L (mm)
82	405	168
110	405	168

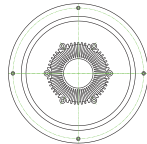
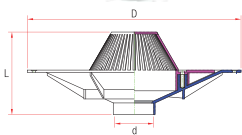

Rain Water Outlet With Extension



D (mm)	d (mm)	H (mm)
110	270	146

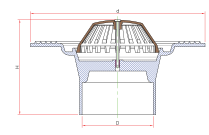
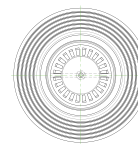

Corner Roof Outlet



D (mm)	H (mm)	W (mm)
82	154	194
110	154	194

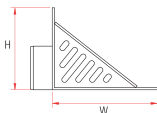
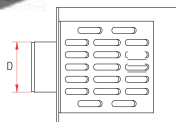

Balcony Drain With Side Outlet



Z (mm)	D (mm)	d (mm)	L (mm)
100	56	50	68
150	56	50	70

Material : ABS

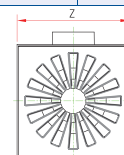
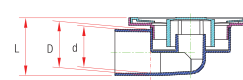

Female Adapter



D (mm)	L (mm)	T
36	47	1¼"
43	52	1½"
56	57	1½"

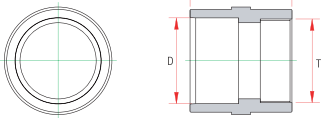

Male Adapter



D (mm)	L (mm)	T
36	47	1¼"
43	52	1½"
56	57	2"

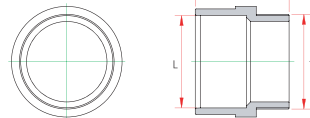

Shower Elbow



D (mm)	d	L (mm)
43	1½"	56

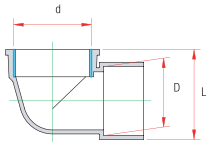

Reducer For Shower Elbow



D (mm)	d (mm)	L (mm)	L1 (mm)	L2 (mm)
56	43	52.5	25	25

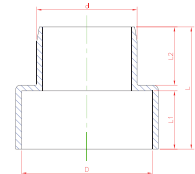

Pipe Plug



D (mm)	H (mm)
40	-
43	24
50	50.3
56	25.3
75	60.4
82	35.2
110	46
160	51.4
200	57

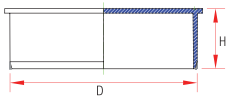

End Cap



D (mm)	H (mm)
36	20
43	20
50	41.2
56	23.2
75	53.6
82	28.2
110	31
160	32.5
200	41.5
250	55
315	59

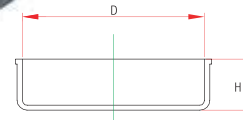

uPVC Floor Trap Cover Model(1)



D (mm)	Z (mm)	L (mm)
110	150	27.5

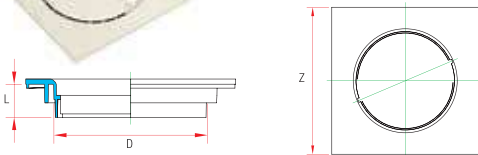

uPVC Floor Trape Cover - Model (2)



L (mm)	Z (mm)	D (mm)
150	22	110

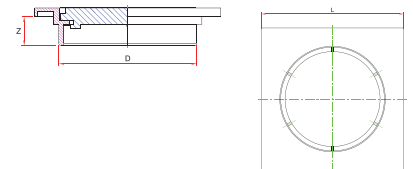

Floor Trap Mesh



L (mm)	Z (mm)	D (mm)
150	27	98

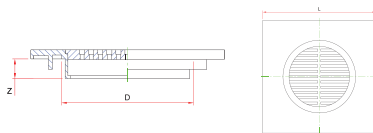

uPVC Floor Clean Out



D (mm)	Z (mm)	L (mm)
110	150	27.5

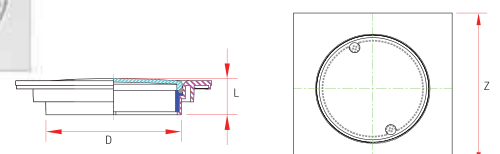

Rodding Eye Cover



D (mm)	W (mm)
110	146

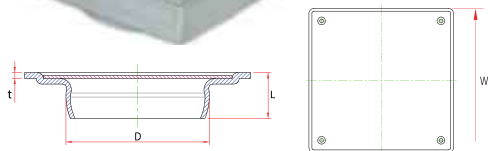

Stainless Steel Floor Clean Out



D (mm)	Z (mm)	L (mm)	t (mm)
110	150	27.5	2m
110	150	27.5	3m

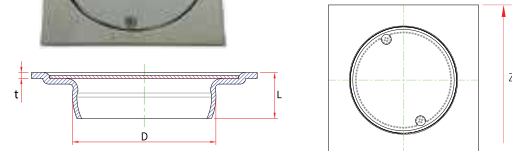

available in SS 304 & 316

Stainless Steel Floor Drain Cover



D (mm)	Z (mm)	L (mm)	t (mm)
110	150	27.5	2m
110	150	27.5	3m

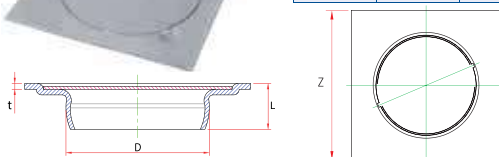

available in SS 304 & 316

SS Balcony Drain Cover



Z (mm)	D (mm)	L (mm)	t (mm)
79	50	16	2

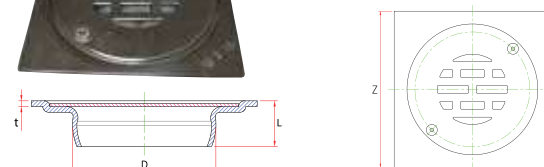

Rubber Ring (Push-Fit) Joints

Cosmoplast pipes and fittings with rubber ring (push-fit) joints present many advantages, like the ease of installation especially in tight places. It also gives the connections the freedom to expand and contract without affecting the joint quality.

The sealing rings used in producing Cosmoplast push fit joints are made of natural / synthetic rubber, offering chemical resistance to wide range of chemicals. The rings also provide an effective seal against internal and external water pressure and against penetration by tree roots.

uPVC Drainage Pipe



D (mm)	L (mm)
* 40	5,8 / 6m
50	5,8 / 6m
56	5,8 / 6m
75	5,8 / 6m
82	5,8 / 6m
110	5,8 / 6m
160	5,8 / 6m
200	5,8 / 6m
250	5,8 / 6m
315	5,8 / 6m

87.5° Elbow "Push Fit"

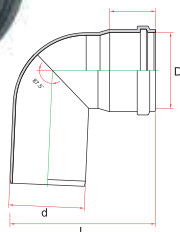

D (mm)	d (mm)	L (mm)
* 40	40	113
50	50	125
56	56	133
75	75	170
82	82	168
110	110	225
160	160	308
200	200	373
250	250	430

87.5° Long Elbow "Push Fit"

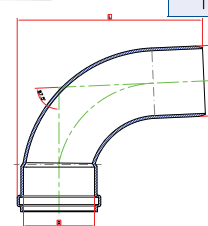

D (mm)	d (mm)	L (mm)
82	82	219
110	110	276

45° Elbow "Push Fit"

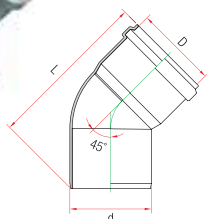

D (mm)	d (mm)	L (mm)
* 40	40	130
50	50	137
56	56	174
75	75	146
82	82	168
110	110	220
160	160	287
200	200	325
250	250	440

45° Y Branch "Push Fit"

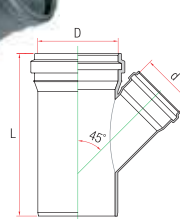

D (mm)	d (mm)	L (mm)
* 40	40	164
50	50	183
56	56	203
75	75	238
82	82	235
110	110	290
160	160	421
200	200	490
250	250	660

45° Reduced Y Branch "Push Fit"

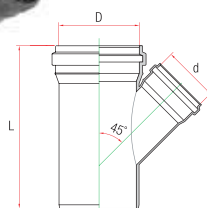

D (mm)	d (mm)	L (mm)
75	50	212
110	75	276
110	82	256
160	110	325
200	110	360
200	160	490
250	160	490
250	200	540

87.5° Tee "Push Fit"

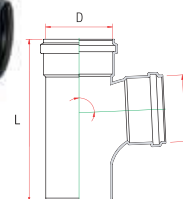

D (mm)	d (mm)	L (mm)
* 40	40	164
50	50	174
56	56	169
75	75	215
82	82	168
110	110	280
160	160	407
200	200	410
250	250	560



* Manufactured on special order

87.5° Reduced Tee "Push Fit"

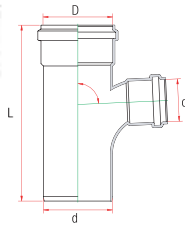

D (mm)	d (mm)	L (mm)
75	50	191
110	50	188
110	75	236
110	82	224
160	110	325
200	160	370
250	200	560

Coupler "Push Fit"

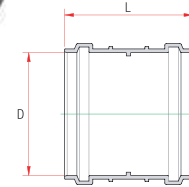

D (mm)	L (mm)
* 40	110
50	110
56	108
75	131
82	113
110	159
160	168
200	230
250	270

Repair Coupler "Push Fit"

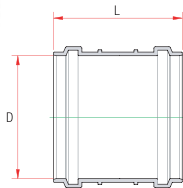

D (mm)	L (mm)
56	108
82	115
110	159
160	168
200	230
250	270

Expansion Socket / Single Socket "Push Fit"

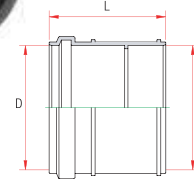

D (mm)	d (mm)	L (mm)
82	82	110
110	110	129
160	160	151

Reducer "Push Fit"

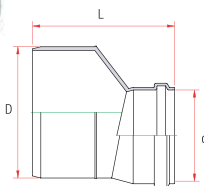

D (mm)	d (mm)	L (mm)
* 50	40	124
75	50	143
82	56	110
110	50	143
110	56	133
110	75	175
110	82	133
160	110	173
200	160	275
250	200	260
250	160	370

87.5° Double Tee "Push Fit"

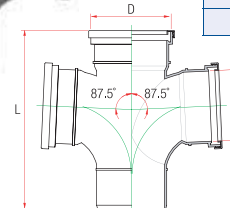

D (mm)	d (mm)	L (mm)
56	56	173
82	82	206
110	110	280
160	160	360

45° Double Y Branch "Push Fit"

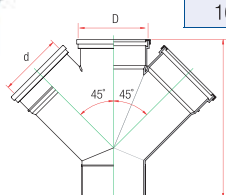

D (mm)	d (mm)	L (mm)
56	56	195
82	82	235
110	110	287
160	160	401

HDPE Aerator with Rubber Ring Socket & Extension

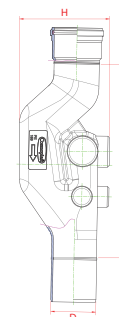

D	H (mm)	L (mm)
110	270	920
160	280	970



* Manufactured on special order

Access Pipe "Push Fit"

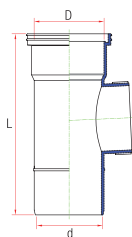

D (mm)	d (mm)	L (mm)
82	82	214
110	110	320
160	160	350

87.5° Access Elbow "Push Fit"

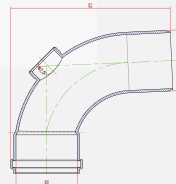

D (mm)	d (mm)	L (mm)
82	82	219
110	110	276
160	160	263

87.5° Access Tee "Push Fit"

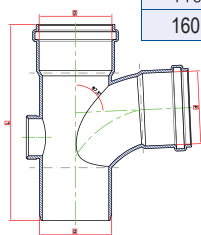

D (mm)	d (mm)	L (mm)
82	82	223
110	110	269
160	160	374

Access Plug "Push Fit"



D (mm)	L (mm)
* 40	75
50	75
56	50
75	89
82	77
110	88
160	95
200	100

Pipe Access Plug

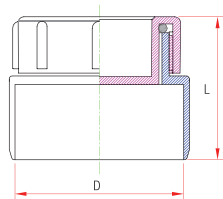

D (mm)	L (mm)
36	47
43	52
56	55
75	72
82	75
110	80
160	95

Pipe Plug

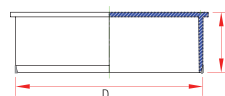

D (mm)	L (mm)
40	-
43	24
50	50.3
56	25.3
75	60.4
82	35.2
110	46
160	51.4
200	57

End Cap

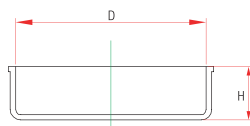

D (mm)	H (mm)
36	20
43	20
50	41.2
56	23.2
75	53.6
82	28.2
110	31
160	32.5
200	41.5
250	55
315	59



* Manufactured on special order

Underground Drainage And Sewerage System

Cosmoplast underground drainage and sewerage system is manufactured from Golden Brown unplasticised polyvinyl chloride uPVC Material.

Cosmoplast underground drainage system is available in two options:

1. Solvent Welding Type: with sizes from 75 mm up to 200 mm.
2. Rubber Ring (Push Fit) Type: with sizes from 40 mm up to 1000 mm.

Cosmoplast underground uPVC pipes and fittings are manufactured according to the latest European Standard BS EN 1401 BSEN 1401 - 1 uPVC Pipes for Underground Drainages :

Mean Outside Diameter		SN 2 SDR 51		SN 4 SDR 41		SN 8 SDR 34		SN 16 SDR 27.6	
min	max	e _{min}	e _{m, max}	e _{min}	e _{m, max}	e _{min}	e _{m, max}	e _{min}	e _{m, max}
110	110.3	-	-	3.2	3.8	3.2	3.8	4.0	4.6
125.0	125.3	-	-	3.2	3.8	3.7	4.3	4.6	5.3
160.0	160.4	3.2	3.8	4.0	4.6	4.7	5.4	5.8	6.6
200.0	200.5	3.9	4.5	4.9	5.6	5.9	6.7	7.3	8.3
250.0	250.5	4.9	5.6	6.2	7.1	7.3	8.3	9.1	10.3
315.0	315.6	6.2	7.1	7.7	8.7	9.2	10.4	11.4	12.8
*355.0	355.7	7.0	7.9	8.7	9.8	10.4	11.7	12.9	14.4
400.0	400.7	7.9	8.9	9.8	11.0	11.7	13.1	14.5	16.2
*450.0	450.8	8.8	9.9	11.0	12.3	13.2	14.8	16.3	18.2
500.0	500.9	9.8	11.0	12.3	13.8	14.6	16.3	18.1	20.2
630.0	631.1	12.3	13.8	15.4	17.2	18.4	20.5	22.8	25.3

Note : 40mm, 50mm, 75mm & 82mm sizes according to BSEN1329 can be produced in orange colour.

* Pipes to these nominal sizes are not normally available in stock.

Push Fit Fittings

uPVC "Push Fit"

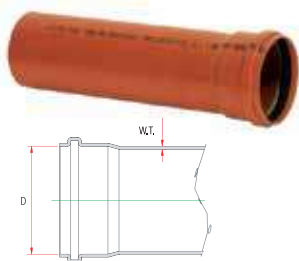

D (mm)	L (m)
*40	5.8/6
50	5.8/6
*56	5.8/6
75	5.8/6
82	5.8/6
110	5.8/6
160	5.8/6
200	5.8/6
250	5.8/6
315	5.8/6
400	5.8/6
500	5.8/6
630	5.8/6

87.5° Elbow "Push Fit"

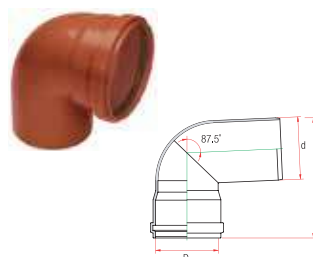

D (mm)	d (mm)	L (mm)
*40	40	113
50	50	125
*56	56	133
75	75	140
82	82	168
110	110	225
160	160	308
200	200	373
250	250	430
315	315	510
**400	400	640
500	500	Fabricated
630	-	Fabricated

87.5° Long Elbow "Push Fit"

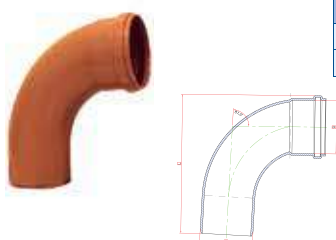

D (mm)	d (mm)	L (mm)
82	82	219
110	110	276

45° Elbow "Push Fit"

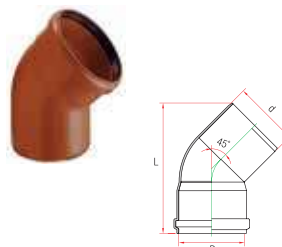

D (mm)	d (mm)	L (mm)
*40	40	130
50	50	137
*56	56	174
75	75	146
82	82	168
110	110	220
160	160	287
200	200	325
250	250	440
315	315	520
**400	400	Fabricated
500	500	Fabricated
630	-	Fabricated



* Manufactured on special order
** Not Manufactured by Cosmoplast



ISO 9001

45°Y Branch "Push Fit"

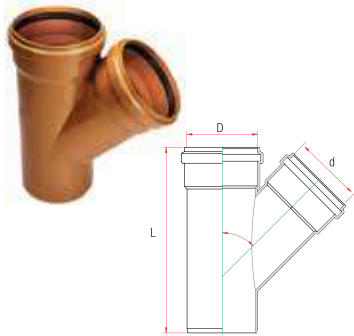

D (mm)	d (mm)	L (mm)
* 40	40	164
50	50	183
* 56	56	203
75	75	238
82	82	235
110	110	290
160	160	421
200	200	490
250	250	660
315	315	820
* 400	400	Fabricated
500	500	Fabricated

45° Reduced Y Branch "Push Fit"

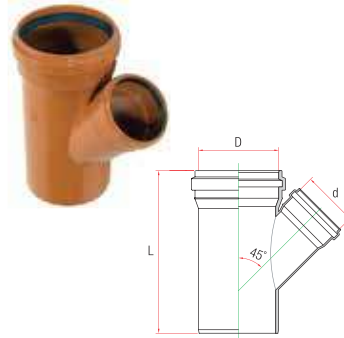

D (mm)	d (mm)	L (mm)
75	50	212
110	75	276
110	82	256
160	110	325
200	160	490
200	110	360
250	200	520
250	160	470

87.5° Tee "Push Fit"

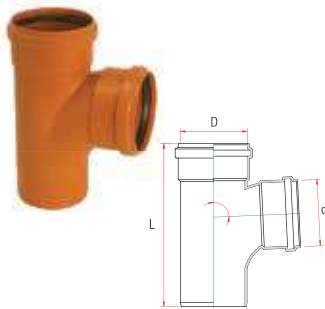

D (mm)	d (mm)	L (mm)
* 40	40	164
50	50	174
* 56	56	169
75	75	215
82	82	168
110	110	280
160	160	407
200	200	410
250	250	560
315	315	680
* 400	400	880
500	500	Fabricated

87.5° Reduced Tee "Push Fit"

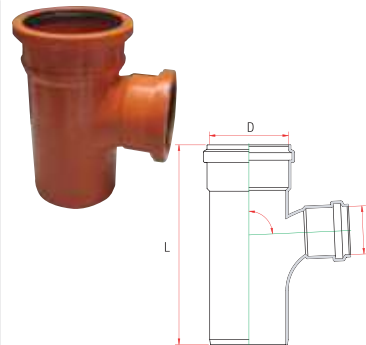

D (mm)	d (mm)	L (mm)
75	50	191
110	75	236
110	82	224
160	110	325
200	160	370
250	200	560

Coupler "Push Fit"

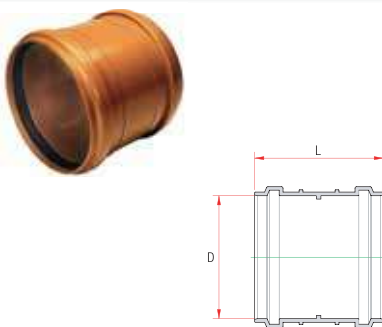

D (mm)	L (mm)
* 40	110
50	110
* 56	108
75	131
82	113
110	159
160	168
200	230
250	270
315	315

Repair Coupler Push Fit"

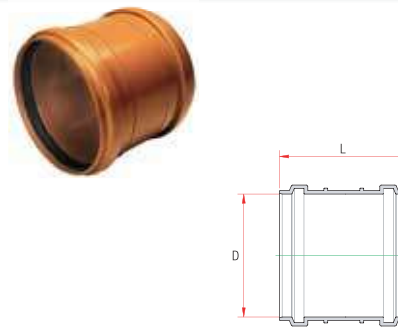

D (mm)	L (mm)
82	115
110	159
160	168
200	230
250	270
315	310
* 400	Fabricated
500	Fabricated
630	Fabricated

Expansion Socket / Single Socket "Push Fit"

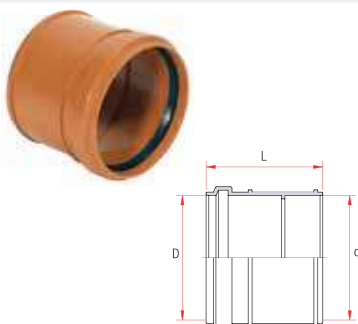

D (mm)	d (mm)	L (mm)
82	82	110
110	110	129
160	160	151

Reducer "Push Fit"

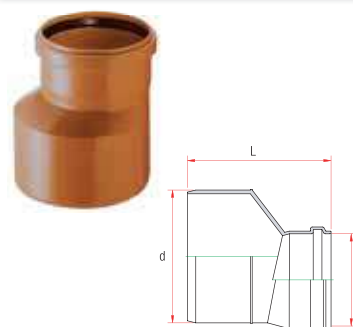

D (mm)	d (mm)	L (mm)
* 50	40	124
75	50	143
82	56	110
* 110	56	133
110	75	175
110	82	133
160	110	173
200	160	275
250	160	370
250	200	260
315	250	300



* Manufactured on special order

45° Double Y Branch "Push Fit"



D (mm)	d (mm)	L (mm)
82	82	235
110	110	287
160	160	401

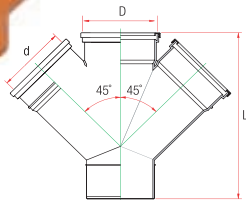

87.5° Double Tee "Push Fit"



D (mm)	d (mm)	L (mm)
82	82	206
110	110	280
160	160	360

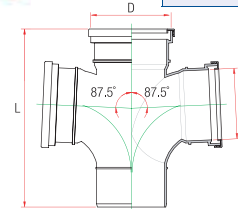

87.5° Access Tee "Push Fit"



D (mm)	d (mm)	L (mm)
82	82	223
110	110	269
160	160	374

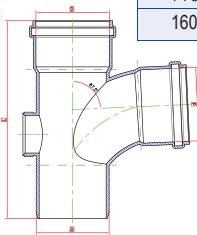

Access Pipe "Push Fit"



D (mm)	d (mm)	L (mm)
82	82	214
110	110	320
160	160	350

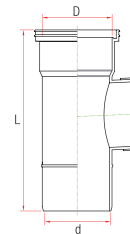

87.5° Access Elbow "Push Fit"



D (mm)	d (mm)	L (mm)
82	82	219
110	110	276
160	160	263

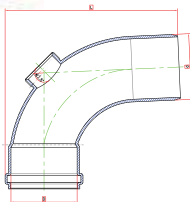

Access Plug



D (mm)	L (mm)
* 40	75
50	75
75	89
82	77
110	88
160	95
200	100



End Cap



D (mm)	H (mm)
36	20
43	20
50	41.2
56	23.2
75	53.6
82	28.2
110	31
160	32.5
200	41.5
250	55
315	59



Pipe Plug



D (mm)	L (mm)
40	-
43	24
50	50.3
56	25.3
75	60.4
82	35.2
110	46
160	51.4
200	57

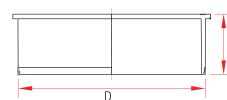

Solvent Welding Joints

uPVC Drainage Pipe (ss)

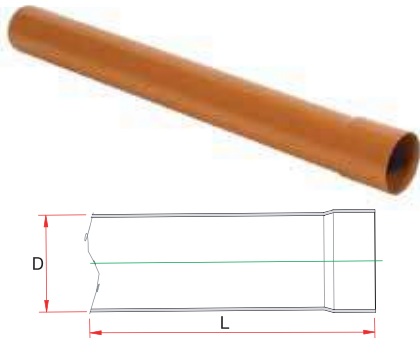

D (mm)	L (m)
50	5.8/6
75	5.8/6
82	5.8/6
110	5.8/6
160	5.8/6
200	5.8/6

87.5° Elbow

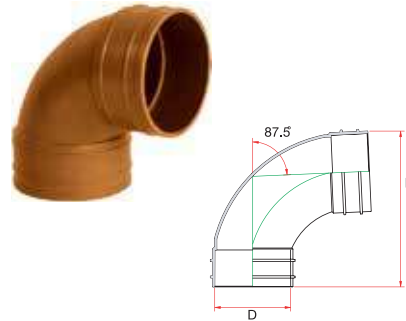

D (mm)	L (mm)
50	101
75	137
82	170
110	190
160	329
200	305

45° Elbow

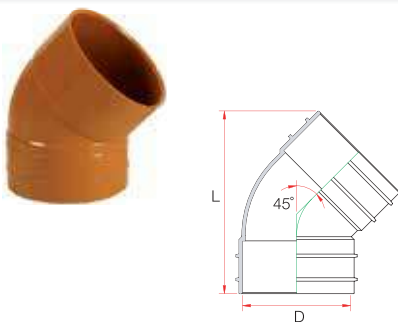

D (mm)	L (mm)
50	86
75	128
82	139
110	170
160	269
200	290

Coupler

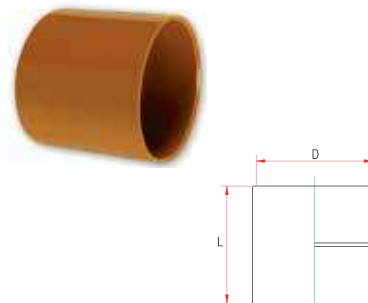

D (mm)	L (mm)
50	52
75	83
82	96
110	112
160	161
200	140

87.5° Tee Branch

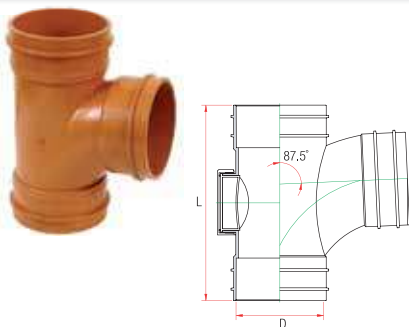

D (mm)	L (mm)
50	106
75	167
82	205
110	250
160	358
200	365

87.5° Reduced Tee

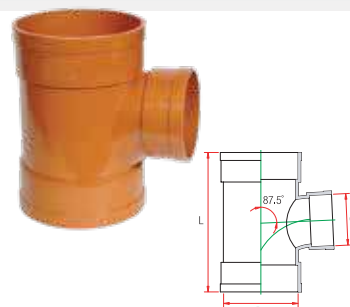

D (mm)	d (mm)	L (mm)
82	56	162
110	50	156
110	56	167
110	82	201
160	110	250
200	160	360

45° Y Branch

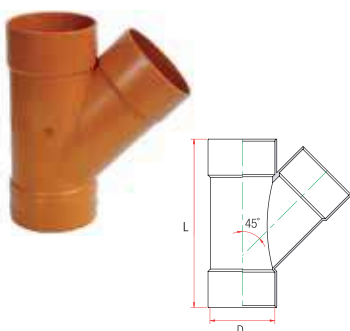

D (mm)	L (mm)
50	125
75	192
82	205
110	268
160	337
200	400

45° Reduced Y Branch

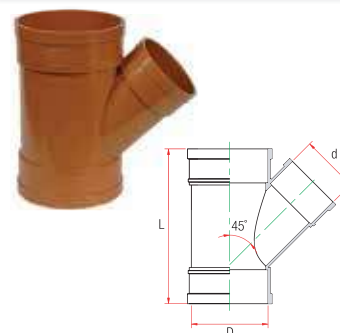

D (mm)	d (mm)	L (mm)
82	56	179
110	50	175
110	82	223
160	110	380
200	160	400

Double Y Branch



D (mm)	d (mm)	L (mm)
110	110	260

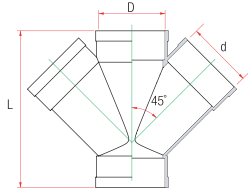

Double Tee Branch



D (mm)	d(mm)	L(mm)
110	110	219
160	160	217

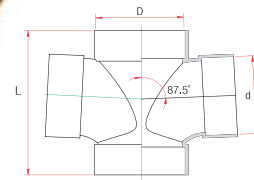

Reducer Bush



D (mm)	d (mm)	L (mm)
43	36	21.3
56	36	27.7
56	43	28.2
75	50	42
82	43	37.6
82	56	37.3
110	50	56
110	56	50
110	75	56
110	82	50
160	110	74.7
200	160	92.2

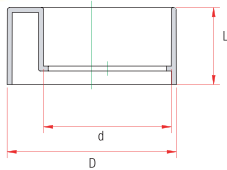

Access Plug & Cap



D (mm)	L (mm)
50	75
75	86
82	77
110	88
160	95
200	100

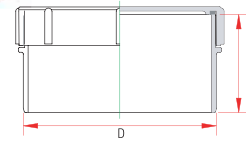

87.5° Access Elbow



D (mm)	L(mm)
110	190
160	329

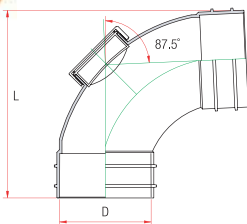

Access Pipe (Socket)



D (mm)	L (mm)
110	219
160	259

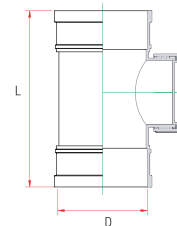

Short Floor Trap



D (mm)	d (mm)	d1 (mm)	H (mm)
110	75	50	120

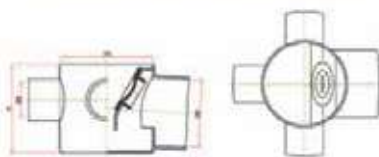

45° Access Elbow



D (mm)	L(mm)
110	170

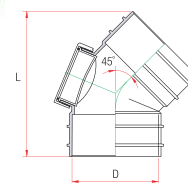

87.5° Access Tee

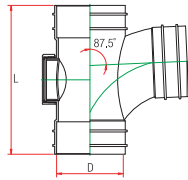

D (mm)	L(mm)
110	250
160	358

Bottle Trap

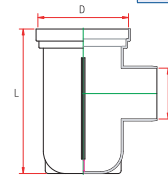

D (mm)	d (mm)	L (mm)
160	110	290

Gully Trap

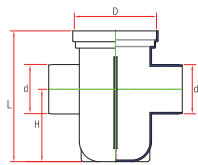

D (mm)	d (mm)	L (mm)	H (mm)
160	110	290	150

Bottle Gully Trap

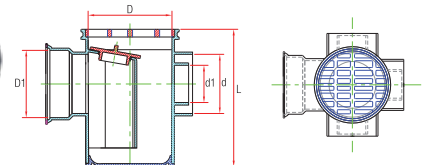

D (mm)	D1(mm)	d (mm)	d1(mm)	L (mm)
160	110	110	50	270

P Trap

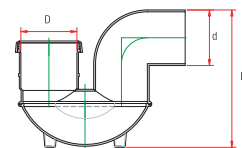

D (mm)	d (mm)	L (mm)
110	110	290

Long P Trap Rubber

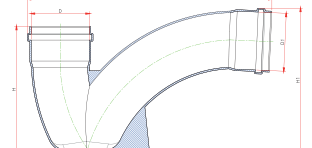

D1 (mm)	D2 (mm)	L (mm)	H (mm)	H1 (mm)
110	110	240	276	466

Square Hopper Grating

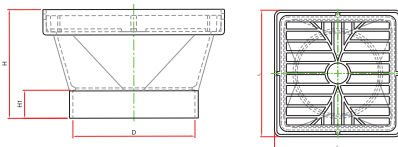

D (mm)	L(mm)	H (mm)	H1(mm)
110	164	98	25

V-Type P Trap Solvent

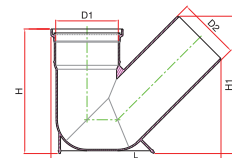

D1 (mm)	D2 (mm)	L (mm)	H (mm)	H1 (mm)
110	110	303	216	245

uPVC Floor Trap

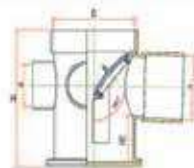

D (mm)	d (mm)	d1 (mm)	H (mm)
110	75	50	172

Pipe Cleaner



Size (L)
½ L
1 L

Solvent Cement



Size (L)
¼ L
½ L
1 L

Rubber Joint Lubricant



Size (L)
1 L

Rubber Lined Pipe Clamp



Size (mm)
36
43
56
82
110
160
200

Unlined Pipe Clamp



Size (mm)
36
43
56
82
110
160

Testing Plug



Size (mm)
43 (38-48)
56 (49-60)
82 (73-85)
110 (94-110)
160 (146-163)
200 (191-211)
244 - 260mm
296 - 314mm

Straight W-Connector



D (mm)	D1(mm)	H(mm)
110	110	128

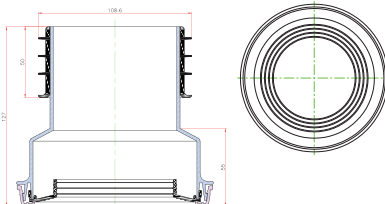

Offset WC Connector



D (mm)	D1(mm)	H(mm)	F(mm)
110	110	128	20
110	110	128	40

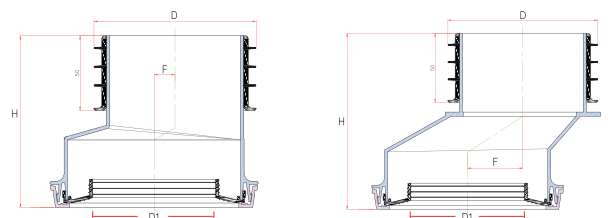

COSMOPLAST UPVC INSPECTION CHAMBERS

Inspection chambers are necessary in every drainage installation for inspection, testing and removal of solids from the drainage system. Cosmoplast Inspection Chamber provides access to the drainage system allowing rodding in both directions.

DEPTH ADJUSTMENT:

The chamber depth can easily be accommodated by installing the chamber risers one over the other to achieve the desired height. The last chamber riser can be trimmed to suit the finished ground level.



COMPONENTS :

Inspection Chamber Base

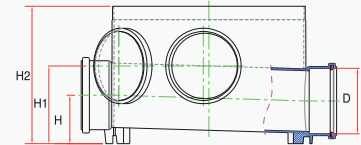
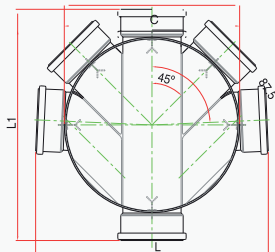

DIMENSIONS (mm)						
D	C	L	L1	H	H1	H2
110	330	450	440	80	130	237

Inspection Chamber Riser

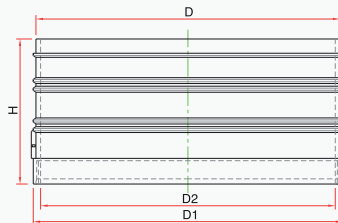

DIMENSIONS (mm)			
D	D1	D2	H
328	335	320	156

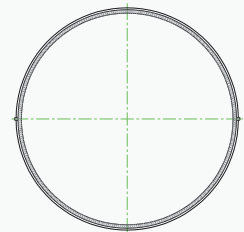

Inspection Chamber Cover

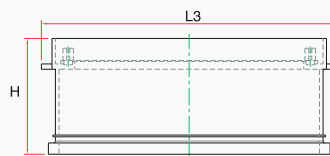

DIMENSIONS (mm)			
L	L1	L3	H
312	312	338	130

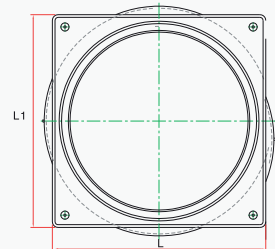

Inspection Chamber Blanking Plug

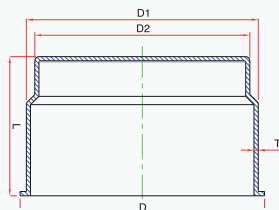

DIMENSIONS (mm)				
D	D1	D2	L	T
116	110	102	66	2

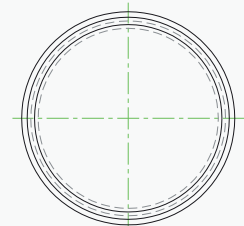

Inspection Chamber Rubber Seal



Perforated & Slotted Pipes

a) Perforated Pipes

Cosmoplast produces wide range of perforated uPVC pipes for Sub-soil drainage applications. The below sketches show the general configurations which may vary depending on size and class of pipe to be perforated.

Parameters		Limits of Variation
Outside diameter	D	32mm to 630mm in standard sizes
Wall thickness	t	In accordance with the class of pipes selected
Longitudinal pitch of holes	p	30mm to 200mm depending on size and class of pipe
Hole Diameter	d	3mm to 10mm depending on size and class of pipe
Number of rows	n	1 to 4
Angular pitch of holes	a	40 degrees for 3 or 4 rows 40, 80 or 120 degrees for 2 rows

Straight rows

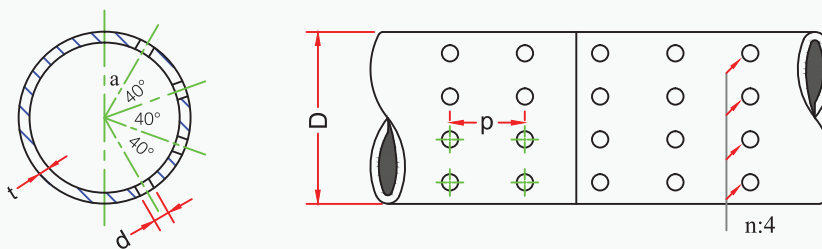

Staggered rows

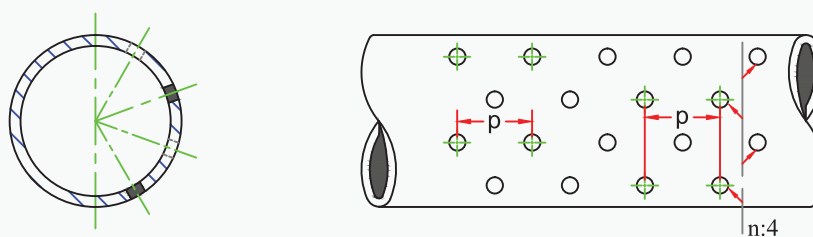

b) Slotted pipes

Cosmoplast produces wide range of SLOTTED uPVC pipes for Sub-soil and Land drain

Cosmoplast uPVC slotted pipes have two rows of circumferential slots which are machine cut and staggered, the slots are cut at an angle of 45° to give a large open area free to carry water. Pipes are slotted to give maximum infiltration as detailed below.

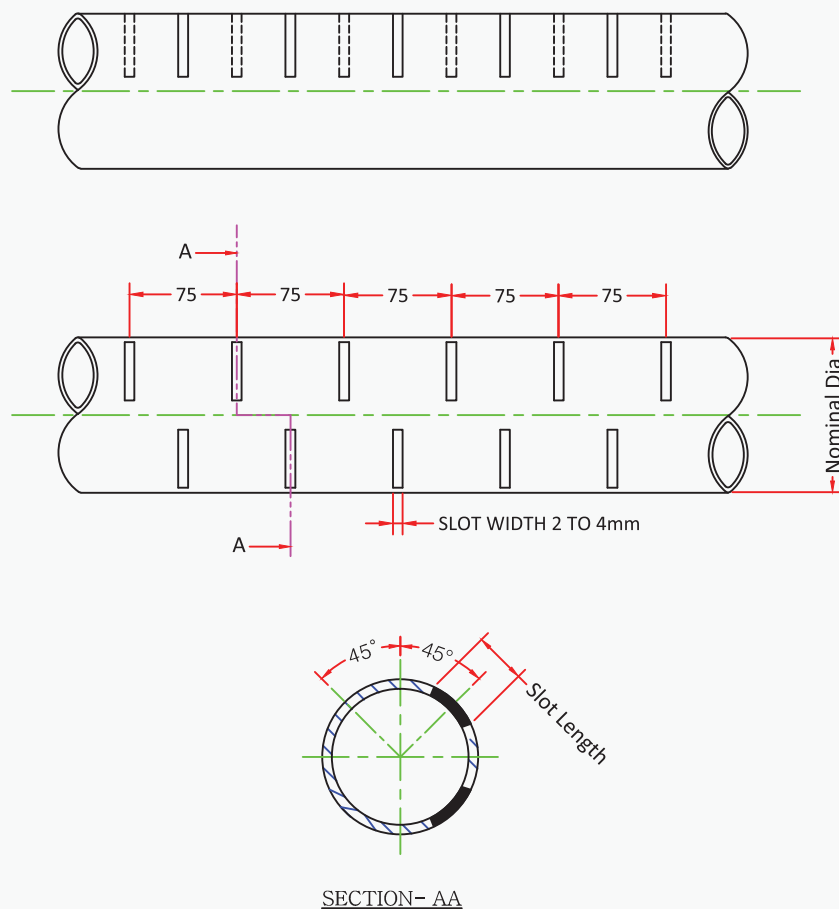

SIZES	SLOT LENGTH		SLOT WIDTH		Min.No.of slot per MTR/ROW	Min.slot Area mm ² /m	PITCH mm
	Min. mm	Max. mm	Min. mm	Max. mm			
110	63	65	2	4	13	4914	75
160	63	65	2	4	13	4914	75
200	76	78	2	4	13	5928	75
225	86	88	2	4	13	6864	75
250	98	100	2	4	13	7644	75
315	120	125	2	4	13	9360	75

Note:

The number of slot, slot width, length, pitch and pattern can be altered to suit specific requirements



WARRANTY

Cosmoplast uPVC pipes and fittings are subjected to continuous tests during production in order to guarantee high quality and reliability.

Cosmoplast Industrial Co. LLC guarantees that its uPVC Pipes & Fittings are free from manufacturing and material defects.

In witness hereof, Cosmoplast issues this warranty for its system of uPVC Pipes and Fittings which shall be valid for a period of ten years starting from the date of installation.

However, Cosmoplast will not accept, and will not be held liable or responsible for damage to these products, or any consequential losses under the following conditions:

1. If working conditions are different than those prescribed in this catalogue.
2. If the components are used in installations where the fluid is not compatible with the material as per the related international standards.
3. If the components present defects when installed, due to incidental factors easily recognizable at the time of installation or when the system is submitted to pressure test.
4. If Cosmoplast components are installed with other items not manufactured by Cosmoplast.
5. In case of poor or inappropriate storage.
6. In case of poor or inappropriate installation, use or operation.

WARRANTY COVERAGE:

This Warranty is limited only to the replacement of the material with manufacturing defects. Cosmoplast will not be liable for any direct or indirect consequential losses or damages.



BS EN 1329/1401



ISO 9001

CERTIFICATE OF REGISTRATION

This is to certify that the management system of
COSMOPLAST INDUSTRIAL COMPANY LLC
 Head Office: P.O. Box 32410, Dubai, U.A.E. - DUBAI, U.A.E.
 Has been registered by Intertek as conforming to the requirements of **ISO 9001:2015**

The management system is applicable to:
 Manufacture and Sale of Plastic Pipes Products covering: Polythene (PE) Pipes and Fittings, Polythene (PE) Pipes and Fittings, Crosslinked Polyethylene (PEX) Pipes and Fittings, Polypropylene (PP) Pipes and Fittings, Hot Insulated Pipes and Fittings.

Certificate Number: 141767
 Issue/Extension Date: 12 May 2017
 Date of Certificate Renewal: 12 May 2021
 Issue from: 12 May 2017
 Valid until: 12 May 2021

For and on behalf of: **Cosmoplast Industrial Co. LLC**
 Head Office: P.O. Box 32410, Dubai, U.A.E. - DUBAI, U.A.E.
 Last Issue: 20170423

Page 3 of 4

Kitemark™ Certificate

This is to certify that:
Cosmoplast Industrial Co. LLC
 (Registration No. 211405/20162)
 Branch of Abu Dhabi 1
 (DUBAI)
 Abu Dhabi
 United Arab Emirates

Kitemark Certificate Number: **KN 55043**

IS in respect of:
BS 5555
Thermoplastic waste pipes and fittings

The issue of this right and licence to use the Kitemark is in accordance with the Kitemark Terms and Conditions governing the use of the Kitemark, as they are updated from time to time by BSI Assurance UK Ltd (the "Licensor"). The use of this Kitemark is authorised in respect of the Product(s) detailed on this Certificate provided it is from the above address.

For and on behalf of: **Gary Ferrin, Quality Product Certification Director**
 First Issue Date: 20150419
 Last Issue: 20170423

Page 3 of 4

Kitemark™ Certificate

This is to certify that:
Cosmoplast Industrial Co. LLC
 (Registration No. 211405/20162)
 Branch of Abu Dhabi 1
 (DUBAI)
 Abu Dhabi
 United Arab Emirates

Kitemark Certificate Number: **KN 55043**

IS in respect of:
BS EN 14021-1
Plastic piping systems for non-pressure underground drainage and sewerage - Unsanitary poly (ethylene) (PVC-U) (PVC-U)

The issue of this right and licence to use the Kitemark is in accordance with the Kitemark Terms and Conditions governing the use of the Kitemark, as they are updated from time to time by BSI Assurance UK Ltd (the "Licensor"). The use of this Kitemark is authorised in respect of the Product(s) detailed on this Certificate provided it is from the above address.

For and on behalf of: **Franz Lieb, Product Certification Technical and Compliance Director**
 First Issue Date: 20140419
 Last Issue: 20170423

Page 3 of 4

Kitemark™ Certificate

No. **KN 55043**

BS EN 14021-1:2014 - Plastic piping systems for non-pressure underground drainage and sewerage, unsanitary poly (ethylene) (PVC-U)

Sl No.	Description	Dimension	Rating	Part(s)
1	Subsoil Pipe	315mm	PN8	EN 14021-1
2	Subsoil Pipe	315mm	PN8	EN 14021-1
3	Subsoil Pipe	315mm	PN8	EN 14021-1
4	Subsoil Pipe	315mm	PN8	EN 14021-1
5	Subsoil Pipe	315mm	PN8	EN 14021-1
6	Subsoil Pipe	315mm	PN8	EN 14021-1
7	Subsoil Pipe	315mm	PN8	EN 14021-1
8	Subsoil Pipe	315mm	PN8	EN 14021-1
9	Subsoil Pipe	315mm	PN8	EN 14021-1
10	Subsoil Pipe	315mm	PN8	EN 14021-1
11	Subsoil Pipe	315mm	PN8	EN 14021-1

All pipes are designated EN 14021-1 or EN 8 2018-1 for use in application areas B and H.

First Issue: 20140419
 Last Issue: 20170423

Page 3 of 6

Kitemark™ Certificate

No. **KN 55043**

BS EN 14021-1:2014 - Plastic piping systems for non-pressure underground drainage and sewerage, unsanitary poly (ethylene) (PVC-U)

Fittings (cont.)

Sl No.	Fitting Type	Dimension	Type of socket
17	Elbow	315mm x 45°	Both EN and SCS
18	Elbow	315mm x 90°	Both EN and SCS
19	Elbow	315mm x 135°	Both EN and SCS
20	Elbow	315mm x 180°	Both EN and SCS
21	Elbow	225mm x 45°	Both EN and SCS
22	Elbow	225mm x 90°	Both EN and SCS
23	Elbow	225mm x 135°	Both EN and SCS
24	Elbow	225mm x 180°	Both EN and SCS
25	Elbow	150mm x 45°	Both EN and SCS
26	Elbow	150mm x 90°	Both EN and SCS
27	Elbow	150mm x 135°	Both EN and SCS
28	Elbow	150mm x 180°	Both EN and SCS
29	Elbow	75mm x 45°	Both EN and SCS
30	Elbow	75mm x 90°	Both EN and SCS
31	Elbow	75mm x 135°	Both EN and SCS
32	Elbow	75mm x 180°	Both EN and SCS
33	Elbow	45mm x 45°	Both EN and SCS
34	Elbow	45mm x 90°	Both EN and SCS
35	Elbow	45mm x 135°	Both EN and SCS
36	Elbow	45mm x 180°	Both EN and SCS
37	Elbow	225mm x 45°	Both EN and SCS
38	Elbow	225mm x 90°	Both EN and SCS
39	Elbow	225mm x 135°	Both EN and SCS
40	Elbow	225mm x 180°	Both EN and SCS
41	Elbow	150mm x 45°	Both EN and SCS
42	Elbow	150mm x 90°	Both EN and SCS
43	Elbow	150mm x 135°	Both EN and SCS
44	Elbow	150mm x 180°	Both EN and SCS
45	Elbow	75mm x 45°	Both EN and SCS
46	Elbow	75mm x 90°	Both EN and SCS
47	Elbow	75mm x 135°	Both EN and SCS
48	Elbow	75mm x 180°	Both EN and SCS
49	Elbow	45mm x 45°	Both EN and SCS
50	Elbow	45mm x 90°	Both EN and SCS
51	Elbow	45mm x 135°	Both EN and SCS
52	Elbow	45mm x 180°	Both EN and SCS

First Issue: 20140419
 Last Issue: 20170423

Page 4 of 6

Kitemark™ Certificate

No. **KN 55043**

BS EN 14021-1:2014 - Plastic piping systems for non-pressure underground drainage and sewerage, unsanitary poly (ethylene) (PVC-U)

Fittings (cont.)

Sl No.	Fitting Type	Dimension	Type of socket
53	Elbow	150mm x 45°	Both EN and SCS
54	Elbow	150mm x 90°	Both EN and SCS
55	Elbow	150mm x 135°	Both EN and SCS
56	Elbow	150mm x 180°	Both EN and SCS
57	Elbow	75mm x 45°	Both EN and SCS
58	Elbow	75mm x 90°	Both EN and SCS
59	Elbow	75mm x 135°	Both EN and SCS
60	Elbow	75mm x 180°	Both EN and SCS
61	Elbow	45mm x 45°	Both EN and SCS
62	Elbow	45mm x 90°	Both EN and SCS
63	Elbow	45mm x 135°	Both EN and SCS
64	Elbow	45mm x 180°	Both EN and SCS
65	Elbow	225mm x 45°	Both EN and SCS
66	Elbow	225mm x 90°	Both EN and SCS
67	Elbow	225mm x 135°	Both EN and SCS
68	Elbow	225mm x 180°	Both EN and SCS
69	Elbow	150mm x 45°	Both EN and SCS
70	Elbow	150mm x 90°	Both EN and SCS
71	Elbow	150mm x 135°	Both EN and SCS
72	Elbow	150mm x 180°	Both EN and SCS
73	Elbow	75mm x 45°	Both EN and SCS
74	Elbow	75mm x 90°	Both EN and SCS
75	Elbow	75mm x 135°	Both EN and SCS
76	Elbow	75mm x 180°	Both EN and SCS
77	Elbow	45mm x 45°	Both EN and SCS
78	Elbow	45mm x 90°	Both EN and SCS
79	Elbow	45mm x 135°	Both EN and SCS
80	Elbow	45mm x 180°	Both EN and SCS

First Issue: 20140419
 Last Issue: 20170423

Page 4 of 6

Kitemark™ Certificate

No. **KN 55042**

BS EN 12521-1:2014-11:2014 - Plastic piping systems for soil and waste discharge (low and high temperatures) within the building structure - Unsanitary poly (ethylene) (PVC-U)

Fittings (cont.)

Sl No.	Fitting Type	Dimension	Type of socket
53	Elbow	110mm x 45°	Both EN and SCS
54	Elbow	110mm x 90°	Both EN and SCS
55	Elbow	110mm x 135°	Both EN and SCS
56	Elbow	110mm x 180°	Both EN and SCS
57	Elbow	75mm x 45°	Both EN and SCS
58	Elbow	75mm x 90°	Both EN and SCS
59	Elbow	75mm x 135°	Both EN and SCS
60	Elbow	75mm x 180°	Both EN and SCS
61	Elbow	45mm x 45°	Both EN and SCS
62	Elbow	45mm x 90°	Both EN and SCS
63	Elbow	45mm x 135°	Both EN and SCS
64	Elbow	45mm x 180°	Both EN and SCS
65	Elbow	225mm x 45°	Both EN and SCS
66	Elbow	225mm x 90°	Both EN and SCS
67	Elbow	225mm x 135°	Both EN and SCS
68	Elbow	225mm x 180°	Both EN and SCS
69	Elbow	150mm x 45°	Both EN and SCS
70	Elbow	150mm x 90°	Both EN and SCS
71	Elbow	150mm x 135°	Both EN and SCS
72	Elbow	150mm x 180°	Both EN and SCS
73	Elbow	75mm x 45°	Both EN and SCS
74	Elbow	75mm x 90°	Both EN and SCS
75	Elbow	75mm x 135°	Both EN and SCS
76	Elbow	75mm x 180°	Both EN and SCS
77	Elbow	45mm x 45°	Both EN and SCS
78	Elbow	45mm x 90°	Both EN and SCS
79	Elbow	45mm x 135°	Both EN and SCS
80	Elbow	45mm x 180°	Both EN and SCS

First Issue: 20140419
 Last Issue: 20170423

Page 3 of 4

Kitemark™ Certificate

No. **KN 55042**

BS EN 12521-1:2014-11:2014 - Plastic piping systems for soil and waste discharge (low and high temperatures) within the building structure - Unsanitary poly (ethylene) (PVC-U)

Part 1: Specifications for pipes, fittings and the system

The scope of this Certificate covers the following pipes:

Diameter	Joint Type
50mm	Both End and Socketed
75mm	Both End and Socketed
110mm	Both End and Socketed
150mm	Both End and Socketed
225mm	Both End and Socketed
315mm	Both End and Socketed
400mm	Both End and Socketed
500mm	Both End and Socketed
600mm	Both End and Socketed
800mm	Both End and Socketed
1000mm	Both End and Socketed

First Issue: 20140419
 Last Issue: 20170423

Page 3 of 4

Kitemark™ Certificate

No. **KN 55042**

BS EN 12521-1:2014-11:2014 - Plastic piping systems for soil and waste discharge (low and high temperatures) within the building structure - Unsanitary poly (ethylene) (PVC-U)

Part 1: Specifications for pipes, fittings and the system

The scope of this Certificate covers the following pipes:

Diameter	Joint Type
50mm	Both End and Socketed
75mm	Both End and Socketed
110mm	Both End and Socketed
150mm	Both End and Socketed
225mm	Both End and Socketed
315mm	Both End and Socketed
400mm	Both End and Socketed
500mm	Both End and Socketed
600mm	Both End and Socketed
800mm	Both End and Socketed
1000mm	Both End and Socketed

First Issue: 20140419
 Last Issue: 20170423

Page 3 of 4

Kitemark™ Certificate

No. **KN 55042**

BS EN 12521-1:2014-11:2014 - Plastic piping systems for soil and waste discharge (low and high temperatures) within the building structure - Unsanitary poly (ethylene) (PVC-U)

Part 1: Specifications for pipes, fittings and the system

The scope of this Certificate covers the following pipes:

Diameter	Joint Type
50mm	Both End and Socketed
75mm	Both End and Socketed
110mm	Both End and Socketed
150mm	Both End and Socketed
225mm	Both End and Socketed
315mm	Both End and Socketed
400mm	Both End and Socketed
500mm	Both End and Socketed
600mm	Both End and Socketed
800mm	Both End and Socketed
1000mm	Both End and Socketed

First Issue: 20140419
 Last Issue: 20170423

Page 3 of 4

Abnahmeprüfzeugnis / Certificate

DIN EN 12521-1:1

System B1, 1000

Artikel / article	System B1, 1000
Artikel / article	10000
Mischungsdatum / compound date	10000
Material / compound	SBR
Norm / standard	EN 881-1
Produktionsdatum / production date	EN 881-1
Produktionsdatum / production date	11000
Ball/Werte / rate values	SB/Werte / results
Härte / hardness	RH/M 60/5 60/4
Zugsfestigkeit / tensile strength	% ≤ 20 17,2
Bruchdehnung / elongation at break	% ≤ 10 20,9
Zugsfestigkeit / tensile strength	MPa ≤ 9 9,6
Bruchdehnung / elongation at break	% ≤ 200 269,3
Änderung der Reißfestigkeit / changing in tensile strength	% max. -20 -8,7
Änderung der Reißdehnung / changing in elongation at break	% max. +10-20 -14,7

Vertrieb: 14.01.2021

Abnahmeprüfzeugnis / Certificate

DIN EN 12521-1:1

System B1, 1000

Artikel / article	System B1, 1000
Artikel / article	10000
Mischungsdatum / compound date	10000
Material / compound	SBR
Norm / standard	EN 881-1
Produktionsdatum / production date	EN 881-1
Produktionsdatum / production date	11000
Ball/Werte / rate values	SB/Werte / results
Härte / hardness	RH/M 60/5 60/4
Zugsfestigkeit / tensile strength	% ≤ 20 14,4
Bruchdehnung / elongation at break	% ≤ 10 19,9
Zugsfestigkeit / tensile strength	MPa ≤ 9 9,2
Bruchdehnung / elongation at break	% ≤ 200 230,1
Änderung der Reißfestigkeit / changing in tensile strength	% max. -20 -9,2
Änderung der Reißdehnung / changing in elongation at break	% max. +10-20 -14,5

Vertrieb: 14.01.2021

SGS

Order No: 4021994-C
 Date: 22-Jan-2019
 Page 01 of 06

WITNESS REPORT

Page 01 of 05

Insurance of order received from M/s. Cosmoplast Industrial Co. LLC through email dated 7th Jan 2019. The below Services were conducted:

- 1. Visual inspection of all deliveries.
- 2. Digital photography taken at the site of test witnessing.
- 3. Evidence of 100% witness report.

The LPCV sample described hereunder was presented to us for test witnessing.

QC Reference	Method/Code	Sl No.	Reference Date
QC Reference	Method/Code	Sl No.	Reference Date
QC Reference	Method/Code	Sl No.	Reference Date
QC Reference	Method/Code	Sl No.	Reference Date
QC Reference	Method/Code	Sl No.	Reference Date

TEST WITNESSING: As per the defined scope of work, the testing done by Cosmoplast Industrial Co. LLC was witnessed. The test specimens and materials were checked by Cosmoplast Industrial Co. LLC. The test results were reviewed by Cosmoplast Industrial Co. LLC staff at the laboratory. Test witnessing is summarized as below:

One sample of LPCV (crosslinked polyethylene) was checked by Cosmoplast Industrial Co. LLC staff at the test witnessing and based on evidence of 100% witness report.

Equipment	Equipment	Serial No.	Calibration	Due date	Calibration conducted by
Equipment	Equipment	Serial No.	Calibration	Due date	Calibration conducted by
Equipment	Equipment	Serial No.	Calibration	Due date	Calibration conducted by
Equipment	Equipment	Serial No.	Calibration	Due date	Calibration conducted by

Checked By: For and on behalf of: **Gary Ferrin, Quality Product Certification Director**

SGS

Order No: 4021994-C
 Date: 22-Jan-2019
 Page 04 of 06

WITNESS REPORT

Page 04 of 05

Insurance of order received from M/s. Cosmoplast Industrial Co. LLC through email dated 7th Jan 2019. The below Services were conducted:

- 1. Visual inspection of all deliveries.
- 2. Digital photography taken at the site of test witnessing.
- 3. Evidence of 100% witness report.

The LPCV sample described hereunder was presented to us for test witnessing.

QC Reference	Method/Code	Sl No.	Reference Date
QC Reference	Method/Code	Sl No.	Reference Date
QC Reference	Method/Code	Sl No.	Reference Date
QC Reference	Method/Code	Sl No.	Reference Date
QC Reference	Method/Code	Sl No.	Reference Date

TEST WITNESSING: As per the defined scope of work, the testing done by Cosmoplast Industrial Co. LLC was witnessed. The test specimens and materials were checked by Cosmoplast Industrial Co. LLC. The test results were reviewed by Cosmoplast Industrial Co. LLC staff at the laboratory. Test witnessing is summarized as below:

One sample of LPCV (crosslinked polyethylene) was checked by Cosmoplast Industrial Co. LLC staff at the test witnessing and based on evidence of 100% witness report.

Equipment	Equipment	Serial No.	Calibration	Due date	Calibration conducted by
Equipment	Equipment	Serial No.	Calibration	Due date	Calibration conducted by
Equipment	Equipment	Serial No.	Calibration	Due date	Calibration conducted by
Equipment	Equipment	Serial No.	Calibration	Due date	Calibration conducted by

Checked By: For and on behalf of: **Gary Ferrin, Quality Product Certification Director**

SGS

Order No: 4021994-C
 Date: 22-Jan-2019
 Page 05 of 06

WITNESS REPORT

Page 05 of 05

Insurance of order received from M/s. Cosmoplast Industrial Co. LLC through email dated 7th Jan 2019. The below Services were conducted:

- 1. Visual inspection of all deliveries.
- 2. Digital photography taken at the site of test witnessing.
- 3. Evidence of 100% witness report.

The LPCV sample described hereunder was presented to us for test witnessing.

QC Reference	Method/Code	Sl No.	Reference Date
QC Reference	Method/Code	Sl No.	Reference Date
QC Reference	Method/Code	Sl No.	Reference Date
QC Reference	Method/Code	Sl No.	Reference Date
QC Reference	Method/Code	Sl No.	Reference Date

TEST WITNESSING: As per the defined scope of work, the testing done by Cosmoplast Industrial Co. LLC was witnessed. The test specimens and materials were checked by Cosmoplast Industrial Co. LLC. The test results were reviewed by Cosmoplast Industrial Co. LLC staff at the laboratory. Test witnessing is summarized as below:

One sample of LPCV (crosslinked polyethylene) was checked by Cosmoplast Industrial Co. LLC staff at the test witnessing and based on evidence of 100% witness report.

Equipment	Equipment	Serial No.	Calibration	Due date	Calibration conducted by
Equipment	Equipment	Serial No.	Calibration	Due date	Calibration conducted by
Equipment	Equipment	Serial No.	Calibration	Due date	Calibration conducted by
Equipment	Equipment	Serial No.			

Pipeline Systems

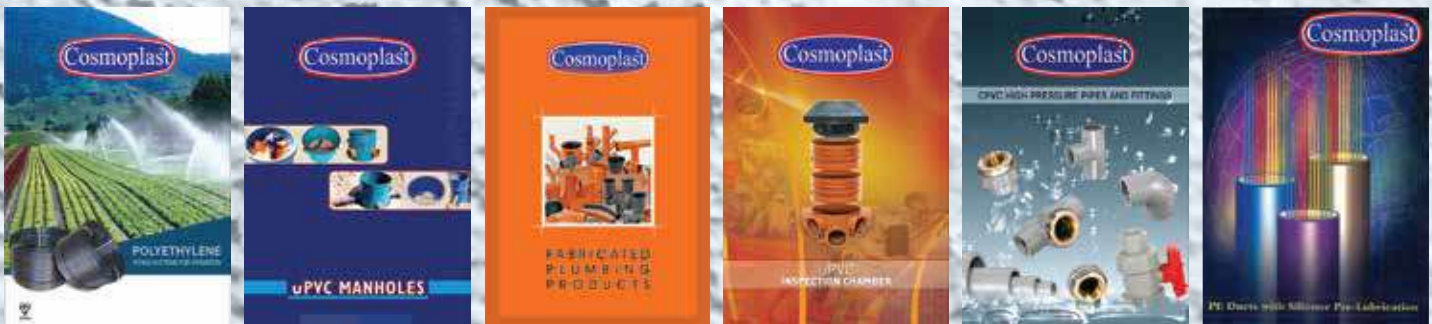

www.cosmoplast.com

Cosmoplast Industrial Co. L.L.C

Sharjah

Sales Off. Tel: +971 6 5331212
 Fax: +971 6 5331917 / 5332901
 P.O. Box: 6032

Dubai

Tel: +971 4 8850500
 Fax: +971 4 8850700
 P.O. Box: 50488

Abu Dhabi

Sales Off. Tel: +971 2 5515364
 Fax: +971 2 5515365
 P.O. Box: 8593

Saudi Arabia-Riyadh

Sales off. Tel: +966 11 265 4501
 Fax: +966 11 471 4669
 Email: pipeline@interplast-ksa.com

Qatar-Doha

Tel.: +974 44687881/2
 Fax: +974 44687886
 Email: info@harwalqa.com

Email: pipeline@cosmoplast.com

